

In-situ NO_x/O₂ Monitor

INM-700



For improved process monitoring, rapid control capability, and lower life cycle costs, you need an analyzer that delivers:

- Feature ① **High spatial resolution**
- Feature ② **Fast response time**
- Feature ③ **Easy installation and operation**

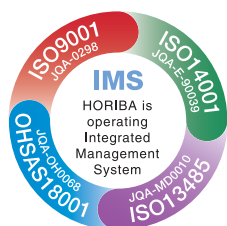

The INM-700's combination of unique, proven technology and easy operation delivers improved

Versatile, compact in-situ design is the best option for process monitoring and control

The HORIBA In-situ NOx/O₂ analyzer's rugged, compact design allows placement indoors or outdoors. The probe may be mounted directly in the stack or close to combustion sources through a single port. The INM-700 offers easy installation and operation for accurate measurement of NOx/O₂ for real time monitoring and control. Using a unique Zirconium Oxide sensor and a non-extractive probe, the INM-700 offers fast response times of less than 10 seconds for on-demand gas flow control and process optimization. An air-cooled probe provides continuous and stable measurements in harsh high temperature environments.



Applications include

- Monitoring for Selective Catalytic Reduction (SCR) ammonia control process
- Boiler tuning, supervision and control of low NOx and standard burners
- Over-fire air injection systems
- Cogeneration SCR monitoring and control

Feature 2 Fast response time

Fast response times within 10 seconds enable realtime process control operations such as combustion emissions measurement for improved efficiency, productivity, and cost savings.

- Controls ammonia injection on SCR systems
- Improves monitoring of combustion efficiency
- Provides real time data for process control applications

Probe unit

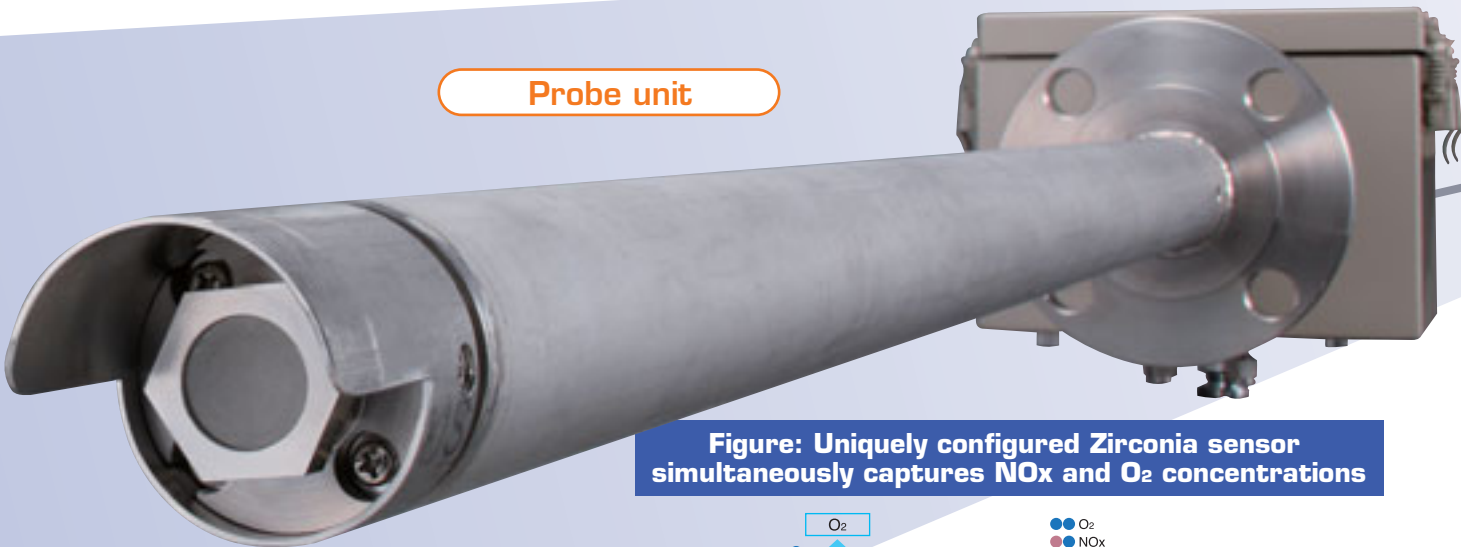
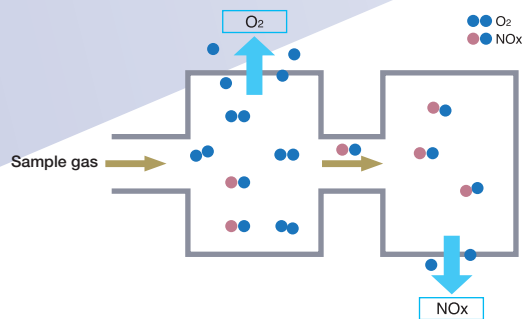

Figure: Uniquely configured Zirconia sensor simultaneously captures NOx and O₂ concentrations



INM-700 is the optimum NOx/O₂ monitor for control and efficiency in SCR NOx removal systems. Unlike conventional extractive gas monitors, the INM-700 In-situ NOx/O₂ monitor needs no sample handling unit.

monitoring and process control.

Feature 1 High spatial resolution

Compact and efficient by design the analyzer consists of a controller unit and a probe unit. The probe facilitates precise placement at critical flow areas to provide high spatial resolution, rapid response times, and measurement integrity.

- No requirements for installation of sampling hardware
- Small profile for tight applications
- Readily retrofitted onto existing facilities

Controller unit



Easy to use control unit

- Easy to read, high brightness display with intuitive menu commands
- RS-232C for PC connection
- Industry standard CSV file format



Simple system configuration

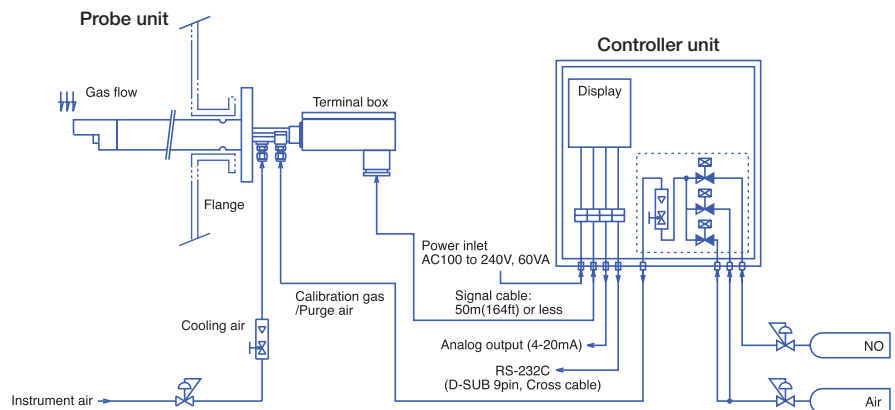

※INM-700 includes Controller unit and Probe unit only.

Feature 3 Easy installation and operation

Versatile control unit may be located almost anywhere. Probe is easy to set up and maintain.

- Mounted to a single ANSI standard flange
- Probe located up to 50 meters from controller (standard)
- Equipped with auto calibration function
- No optical alignment
- Low maintenance with long-life sensor
- Unique sensor refresh mode



The right choice for a broad spectrum of applications spanning cogeneration facilities, industrial processing, and large, centralized utilities

The INM-700's small profile and high performance fills the monitoring and process control needs for cogeneration systems at airports, hospitals, universities, municipalities, and industries. The high temperature tolerance of the INM-700 allows In-situ probe placement close to combustion processes for rapid and highly accurate measurement with precise spatial resolution. The result is more efficient and economical operation and higher productivity for combustion intensive industries including petroleum refining, forest products, steel, chemicals, glass, and metal casting. The INM-700 has proven to be an extremely reliable and cost effective tool for emissions control strategies at large power plants.

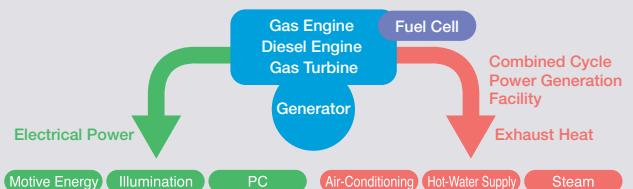

Specifications

Model	INM-700
Principle	Zirconium sensor Type (Demarcation current) ^{※1}
Measuring range	NOx : 0-1000ppm, O ₂ : 0-25vol%
Repeatability	± 1.0% of full scale
Drift	± 2.0% of full scale/week ^{※2}
Response time (T ₉₀)	10 sec. or less
Linearity	± 3.0% of full scale
Warm up time	Approx. 5 min.
Display	LED digital display (effective 4 digits) for measuring value LCD display for parameter setting
Output signal	DC 4 to 20 mA isolated, Maximum permissible load 600 Ω
External output	NOx high/low-alarm, O ₂ high/low-alarm, Power failure alarm, Abnormal
Calibration	DRY calibration, Automatic (1 hour to 99 days 23 hours configurable), Manual
Calibration gas	O ₂ Zero: Standard gas (NO), O ₂ Span: Cylinder air, NO Zero: Cylinder Air, NO Span: Standard gas (NO)
Sampling probe	Flange: JIS5K65AFF, Probe length: 520mm [20.47 inch], Material: SUS316
Sensor cable length	Max. 50 m [164 ft.]
Installation condition	Indoor or outdoor, Operational temperature: -10 to 50°C [23 to 122°F], Humidity: 90% RH (non condensing)
Power	AC100 V to 240 V
Power consumption	Approx. 60 VA
Frequency	50/60Hz
Mass	Probe unit: Approx. 10 kg [Approx. 22lbs] Controller unit: Approx. 20 kg [Approx. 44lbs]
Cooling air (Instruments air) ^{※3}	
Dew Point	-20 °C [-4°F] or less
Pressure	Approx. 300kPa
Consumption	350°C~400°C[662°F~752°F] Approx.70L/min. [2.47 cfm] 300°C~350°C[572°F~662°F] Approx.50L/min. [1.77 cfm] 200°C~300°C[392°F~572°F] Approx.40L/min. [1.41 cfm]
Purge air (Cylinder air) ^{※4}	
Temperature	25°C [77°F] or less (No dust, mist and Non-condensing moisture content: 0.6% or less at 0°C [23°F])
Pressure	Approx. 300kPa
Consumption	Approx. 3L/min.
Sample gas condition ^{※5}	Pressure: ± 3kPa Velocity: 20m/sec. or less Temperature: 400 °C [752°F] or less Dust: 20g/m ³ or less O ₂ : 1-25vol%, CO ₂ : 0-20vol% H ₂ O : 3-20vol%, SO : 1000ppm or less

※1 Compared to the actual value, the measured value changes according to the moisture content in the target gas because of wet-basis measurements (effect on the indicated value by the partial pressure of water).

※2 First week of operation at ± 2.0% of full scale per day.

※3 No Oil mist and dust. When instruments air cannot be arranged that satisfies these conditions, handle by arranging a small compressor or similar equipment.

Dimensional Outline Unit: mm (in)

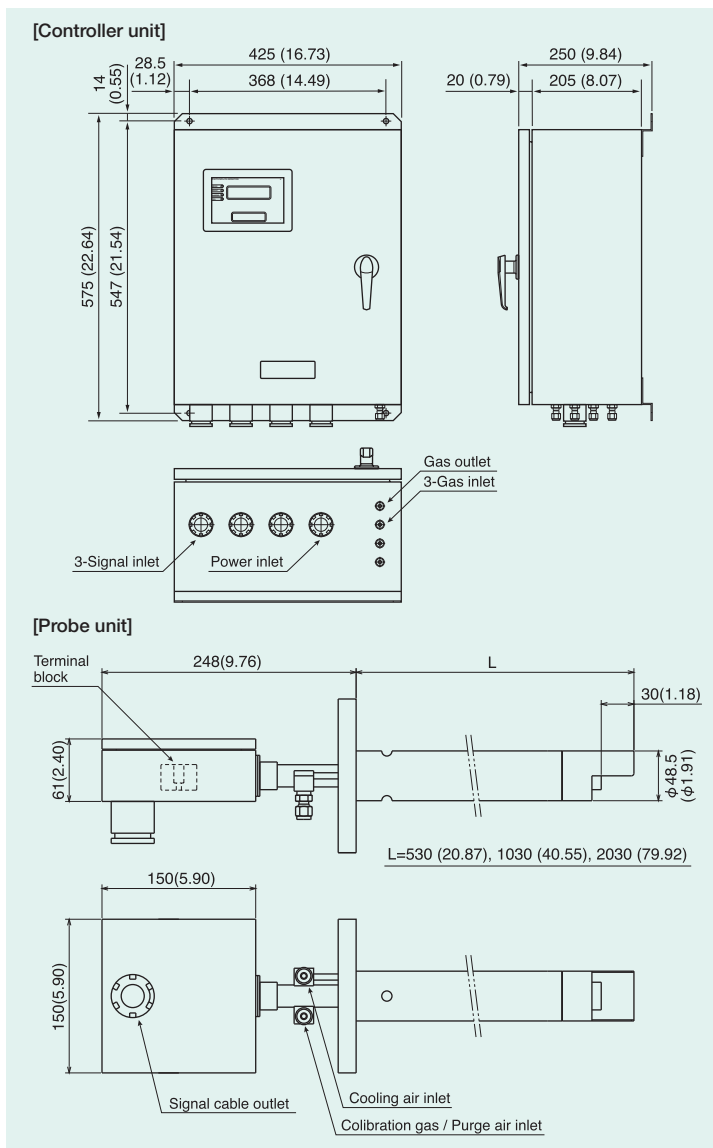

※4 Instead of cylinder air, instrument air that is free of oil and mist may be used for calibration and purge air.

※5 Please consult HORIBA for more specific sample conditions.



Please read the operation manual before using this product to assure safe and proper handling of the product.

- The contents of this catalog are subject to change without prior notice, and without any subsequent liability to this company.
- The color of the actual products may differ from the color pictured in this catalog due to printing limitations.
- It is strictly forbidden to copy the content of this catalog in part or in full.
- All brand names, product names and service names in this catalog are trademarks or registered trademarks of their respective companies.

<http://www.horiba.com> e-mail: info@horiba.co.jp

● **HORIBA, Ltd.**
Head Office
2 Miyanohigashi, Kisshoin
Minami-ku, Kyoto, Japan
Phone: 81 (75) 313-8123
Fax: 81 (75) 321-5725

● **HORIBA KOREA LTD.**
112-6 Sogong-Dong
Choong-ku, Seoul, Korea
Phone: 82 (2) 753-7911
Fax: 82 (2) 756-4972

● **HORIBA Instruments Pte Ltd**
Head Office
10 Ubi Crescent
Lobby B #05-12, Ubi
Techpark Singapore 408564
Phone: 65 6745-8300
Fax: 65 6745-8155

● **Hanoi Office**
Unit 10, 4 Floor, CMC tower,
Dich Vong Hau Ward, Cau Giay
district, Hanoi, Vietnam
Phone: 84 (4) 3795-8552
Fax: 84 (4) 3795-8553

● **HORIBA Instruments Incorporated**
Irvine Facility
17671 Armstrong Avenue
Irvine, CA 92614, U.S.A.
Phone: 1 (949) 250-4811
Fax: 1 (949) 250-0924

● **HORIBA Europe GmbH**
Head Office
Hans-Mess-Str.6
D-61440 Oberursel/Ts.
Germany
Phone: 49 (6172) 1396-0
Fax: 49 (6172) 1373-85

● **Leichlingen Facility**
Julius-kronenberg Str.9
D-42799 Leichlingen
Germany
Phone: 49 (2175) 8978-0
Fax: 49 (2175) 8978-50

● **HORIBA France**
12, Avenue des Tropiques
F-91955 LES ULIS
France
Phone: 33 (1) 69-29-96-23
Fax: 33 (1) 69-29-95-77

● **HORIBA Instruments Limited**
Kyoto Close
Summerhouse Road
Moulton Park, Northampton
NN3 6FL, England
Phone: 44 (1604) 542-500
Fax: 44 (1604) 542-699

● **HORIBA GmbH**
Kaplanstrasse 5
A-3430 Tulln,
Austria
Phone: 43 (2272) 65225
Fax: 43 (2272) 65230

● **HORIBA Czechia**
Organizacni slozka Praha
Petrohradská 13
CZ-101 00 Praha 10,
Czech Republic
Phone: 420 (2) 717-464-80
Fax: 420 (2) 717-470-64

Bulletin:HRE-2874E

Printed in Japan TH-TF(SK)23