

HORIBA

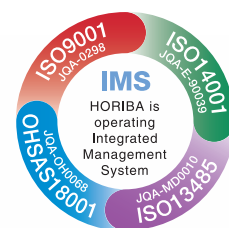

WATER QUALITY

ANALYZERS

SENSOR TECHNOLOGY



- pH
- ORP
- ION
- Conductivity
- DO
- Temperature
- Resistivity
- SALT



<http://www.horiba.com/wq/>

ELECTRODE LINE UP

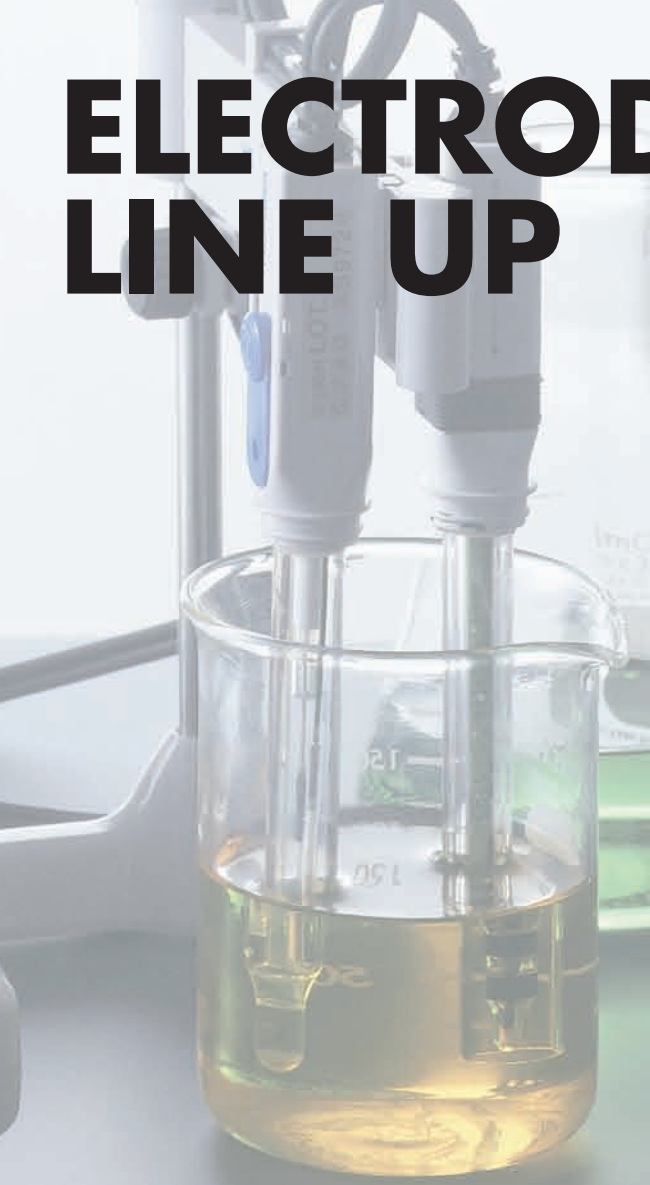

NEW pH



water proof



General laboratory application



3-in-1 Electrode
9611-10D



water proof



Protein, high viscosity application



3-in-1 Sleeve Electrode
9677-10D



water proof



Precious, trace amount sample



3-in-1 Micro Electrode
9669-10D

ToupH

pH (3-in-1)

Sleeve 6367-10D For Test Tubes 6378-10D For Test Tubes 9678-10D For Food Analysis 6252-10D



pH (Combination)

Standard 6066-10C For Extra-Thin Test Tubes 6069-10C Needle Type 6251-10C Flat Type 6261-10C

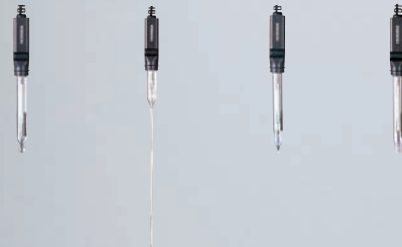

ORP

Metallic Electrode Platinum 3-in-1 Type 9300-10D



Temperature

Temperature Electrode 4163-10T



Conductivity

Immersion Type 3551-10D Immersion Type 3552-10D Immersion Type 3553-10D Immersion Type 9382-10D Flow Type 3561-10D Flow Type 3562-10D Flow Type 3573-10C Flow Type 3574-10C

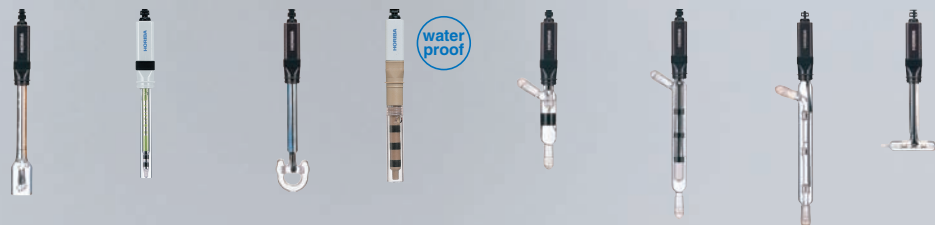

Dissolved Oxygen

Field Use 9551-20D (2 m Cable) Field Use 9551-100D (10 m Cable) Laboratory Use 9520-10D

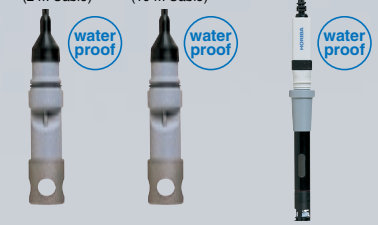



water proof



Tap water, pure water application



3-in-1 Plastic Electrode
9621-10D



Non-glass application for food application, etc.



ISFET Electrode
0030-10D

ISFET

ToupH electrode just got ToupHer!

●Enhanced durability of the glass membrane makes it four times stronger than the conventional ToupH electrode.

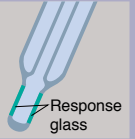

●The patented silver ion trap technology improves response time. The response time is 40 times faster than the conventional electrodes.

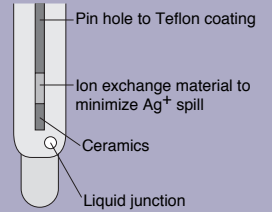

Reference electrode response time over 3 months (tap water).

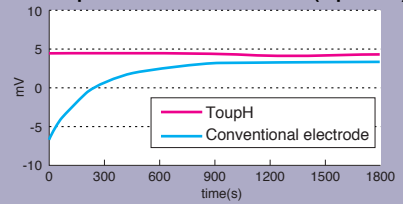

●With enhanced durability, the electrode is more easily maintained with a sponge or optional cleaning reagent.

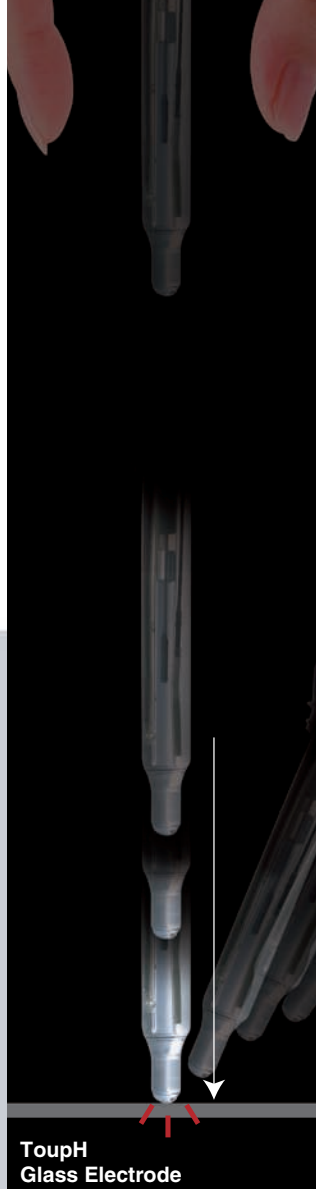

ToupH Glass Electrode

Conventional Glass Electrode

ION

Cyanide Ion Electrode 8001-10C	Chloride Ion Electrode (Combination Type) 6560-10C	Chloride Ion Electrode 8002-10C	Sulfide Ion Electrode 8003-10C	Iodide Ion Electrode 8004-10C	Bromide Ion Electrode 8005-10C	Copper Ion Electrode 8006-10C	Cadmium Ion Electrode 8007-10C	Lead Ion Electrode 8008-10C	Thiocyanate Ion Electrode 8009-10C	Fluoride Ion Electrode (Combination Type) 6561-10C
CN^-	Cl^-	Cl^-	S^{2-}	I^-	Br^-	Cu^{2+}	Cd^{2+}	Pb^{2+}	SCN^-	F^-
Fluoride Ion Electrode 8010-10C	Silver Ion Electrode 8011-10C	Ammonia Electrode (Combination Type) 5002A-10C	Sodium Ion Electrode 1512A-10C	Nitrate Ion Electrode (Combination Type) 6581-10C	Nitrate Ion Electrode 8201-10C	Potassium Ion Electrode (Combination Type) 6582-10C	Potassium Ion Electrode 8202-10C	Calcium Ion Electrode (Combination Type) 6583-10C	Calcium Ion Electrode 8203-10C	
F^-	Ag^+	NH_3	Na^+	NO_3^-	NO_3^-	K^+	K^+	Ca^{2+}	Ca^{2+}	

LABORATORY

navi^h

F-50 Series DS-50 Series



Screen images are superimposed.

- pH**
- ORP**
- ION**
- Conductivity**
- Temperature**
- Resistivity**
- SALT**

Standard pH meter with custom LCD display



F-51BW

pH **ORP**

- RS-232C output (PC/Printer)
- Battery operation possible

Color LCD display with navigation function



F-52

pH **ORP**

- RS-232C output (PC/Printer)

Two channels meter with pH, ORP and ION measurement, color LCD display with navigation function



F-53

CH.1 **pH** **ORP** **ION**
CH.2 **pH** **ORP** **ION**

- RS-232C output (PC/Printer)
- Compact flash

Economical pH, ORP and conductivity meter with custom LCD display



F-54BW

pH **ORP** **COND**

- RS-232C output (PC/Printer)
- Battery operation possible

Color display and navigation function for enhanced user-friendliness.

The world's first 5.7 inch wide screen with color display.



Just press "Navi" key
For operation or troubleshooting menus

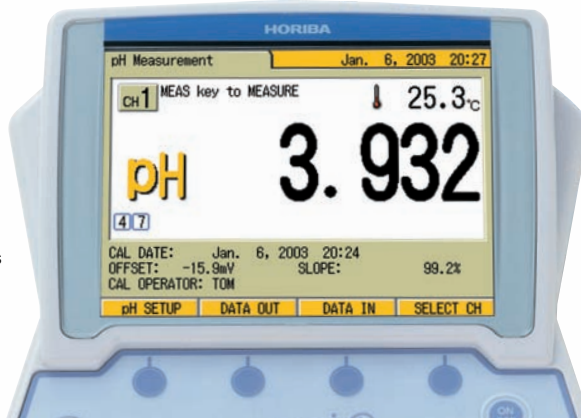
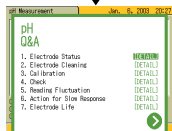

Enhanced data reliability with validation feature.

(GLP/GMP compliance)

Self diagnostic features and optional printer assures data reliability.



Benchtop multi-parameter meter allows measurement of up to 4 parameters.

Electronic record, audit trail and electronic signatures are security function features. (FDA 21CFR Part11 compliance)

Data can be transferred to a PC by compact flash, Ethernet and/or serial connection.



Option



Printer
(For GLP/GMP compliance)

Printer Cable
Part No. 3014030148(9096003800)



Digital Simulator
X-51(pH, ORP, ION, DO,TEMP)
X-52(COND,TEMP)

Two channels meter with pH, ORP and conductivity measurement. Color LCD display with navigation function.



F-54

CH.1 pH ORP
CH.2 COND SALT RESI

- RS-232C output (PC/Printer)
- Compact flash

World's first meter with FDA 21CFR Part11 support measures pH, ORP, conductivity and ION.

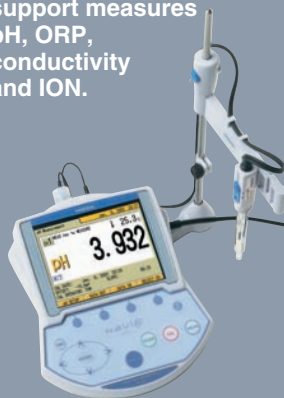

F-55

CH.1 pH ORP ION
CH.2 COND SALT RESI

- RS-232C output (PC/Printer)
- Compact flash
- Ethernet

Standard conductivity meter with custom LCD display



DS-51

COND SALT RESI

- RS-232C output (PC/Printer)
- Battery operation possible
- *Set includes conductivity electrode. (model 3552-10D)

Enhanced conductivity meter with color LCD and navigation function.



DS-52

COND SALT RESI

- RS-232C output (PC/Printer)
- *Set includes conductivity electrode. (model 3552-10D)

Economical meter for pH and temperature



D-51
pH

Multi-parameter for pH/temperature/ORP with PC/printer output capability.



D-52
pH ORP

• RS-232C output (PC/Printer)

Multi-parameter for pH/temperature/ORP/ION with PC/printer output capability



D-53
pH ORP ION

• RS-232C output (PC/Printer)

FIELD

navi^h

D-50 Series
ES-51
OM-51



- pH
- ORP
- ION
- Conductivity
- Temperature
- Resistivity
- SALT
- DO

Multi-parameter for pH/temperature/ORP/ conductivity with PC/printer output capability



D-54

pH **ORP** **COND**

• RS-232C output (PC/Printer)

Multi-parameter for pH/temperature/ORP/ dissolved oxygen with PC/printer output capability



D-55

pH **ORP** **DO**

• RS-232C output (PC/Printer)

Portable conductivity/resistivity/ salinity meter with PC/printer output



ES-51

COND **SALT** **RESI**

• RS-232C output (PC/Printer)

*Set includes conductivity electrode. (model 9382-10D)

Portable dissolved oxygen meter with PC/printer output



OM-51

DO

• RS-232C output (PC/Printer)

*Select from the followings.
 • 2 m cable (OM-51-2)
 • 10 m cable (OM-51-10)
 • Laboratory (OM-51-L1) (BOD measurement)

Revolutionary waterproof meter and electrodes enhance care-free operation in the lab or field.

HORIBA portable meter conforms to waterproof standard of IEC529:IP67.



pH electrode (model 9621-10D) is waterproof down to depth of 1m.

DO electrode (model 9551-20D, 9551-100D) is waterproof down to depth of 10m.

Quick connection to PC allows easy and fast data evaluation.



Portable multi-parameter meter allows measurement of up to 4 parameters.

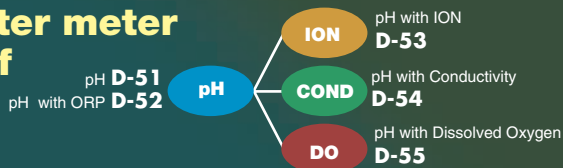

Automatic data-logging function.

Store up to 300 sets of data automatically.

Self diagnostic function assures reliable measurement.

User-friendly self-diagnostic modes for battery voltage, temperature, calibration and LCD checks.

User-friendly features and portability with large LCD display.



Option



Digital Simulator

X-51 (pH, ORP, ION, DO, TEMP)

X-52 (COND, TEMP)



Electrode Stand

Part No. 3014028590(9096002700)

F-50 series / DS-50 series Specifications



		F-51BW	F-52	F-53	F-54BW	F-54	F-55
		pH ORP •RS-232C output (PC/Printer) •Battery operation possible	pH ORP •RS232C printer output	CH.1 pH ORP ION CH.2 pH ORP ION •RS-232C output (PC/Printer) •Compact flash	pH ORP COND •RS-232C output (PC/Printer) •Battery operation possible	CH.1 pH ORP CH.2 COND SALT RESI •RS-232C output (PC/Printer) •Compact flash	CH.1 pH ORP ION CH.2 COND SALT RESI •RS-232C output (PC/Printer) •Compact flash •Ethernet
Measurement method	pH	Glass electrode method	Glass electrode method	Glass electrode method	Glass electrode method	Glass electrode method	Glass electrode method
	ION	—	—	Ion electrode method	—	—	Ion electrode method
	Conductivity	—	—	—	AC bipolar method	AC bipolar method	AC bipolar method
	SALT	—	—	—	—	Conductivity conversion	Conductivity conversion
Measurement range	Resistance	—	—	—	—	Conductivity conversion	Conductivity conversion
	pH	pH0.00 ~ 14.00 Resolution 0.01pH	pH0.000 ~ 14.000 Resolution 0.01/0.001pH	pH0.000 ~ 14.000 Resolution 0.01/0.001pH	pH0.000 ~ 14.000 Resolution 0.001pH	pH0.000 ~ 14.000 Resolution 0.01/0.001pH	pH0.000 ~ 14.000 Resolution 0.01/0.001pH
	mV(ORP)	-1999 ~ 1999 Resolution 1mV	-1999.9 ~ 1999.9 Resolution 0.1mV	-1999.9 ~ 1999.9 Resolution 0.1mV	-1999.9 ~ 1999.9 Resolution 1mV	-1999.9 ~ 1999.9 Resolution 0.1mV	-1999.9 ~ 1999.9 Resolution 0.1mV
	Temperature	0.0 ~ 100.0°C Resolution 0.1°C	0.0 ~ 100.0°C Resolution 0.1°C	0.0 ~ 100.0°C Resolution 0.1°C	0.0 ~ 100.0°C Resolution 0.1°C	0.0 ~ 100.0°C Resolution 0.1°C	0.0 ~ 100.0°C Resolution 0.1°C
	ION	—	—	0.0μ ~ 999g/L (mol/L)	—	—	0.0μ ~ 999g/L (mol/L)
	Conductivity	—	—	—	Cell constant 100m ⁻¹ : 0.000mS/m ~ 19.99S/m Cell constant 10m ⁻¹ : 0.0μS/m ~ 1.999S/m Cell constant 1000m ⁻¹ : 0.00mS/m ~ 199.9S/m Resolution 0.05% F.S.	Cell constant 100m ⁻¹ : 0.000mS/m ~ 19.99S/m Cell constant 10m ⁻¹ : 0.0μS/m ~ 1.999S/m Cell constant 1000m ⁻¹ : 0.00mS/m ~ 199.9S/m Resolution 0.05% F.S.	Cell constant 100m ⁻¹ : 0.000mS/m ~ 19.99S/m Cell constant 10m ⁻¹ : 0.0μS/m ~ 1.999S/m Cell constant 1000m ⁻¹ : 0.00mS/m ~ 199.9S/m Resolution 0.05% F.S.
	SALT	—	—	—	—	0.00 ~ 4.00% Resolution 0.01%	0.00 ~ 4.00% Resolution 0.01%
Resistance	—	—	—	—	Cell constant 100m ⁻¹ : 0.05Ω·m ~ 199.9kΩ·m Cell constant 10m ⁻¹ : 0.5Ω·m ~ 1.999MΩ·m Cell constant 1000m ⁻¹ : 0.005Ω·m ~ 19.99kΩ·m Resolution 0.05% F.S.	Cell constant 100m ⁻¹ : 0.05Ω·m ~ 199.9kΩ·m Cell constant 10m ⁻¹ : 0.5Ω·m ~ 1.999MΩ·m Cell constant 1000m ⁻¹ : 0.005Ω·m ~ 19.99kΩ·m Resolution 0.05% F.S.	
Repeatability	pH	±0.01pH ±1digit	±0.001pH ±1digit	±0.001pH ±1digit	±0.001pH ±1digit	±0.001pH ±1digit	±0.001pH ±1digit
	mV(ORP)	±1mV ±1digit	±0.1mV ±1digit	±0.1mV ±1digit	±1mV ±1digit	±0.1mV ±1digit	±0.1mV ±1digit
	Temperature	±0.1°C ±1digit	±0.1°C ±1digit	±0.1°C ±1digit	±0.1°C ±1digit	±0.1°C ±1digit	±0.1°C ±1digit
	ION	—	—	±0.5%F.S. ±1digit	—	—	±0.5%F.S. ±1digit
	Conductivity	—	—	—	±0.5% F.S. ±1digit	±0.5% F.S. ±1digit	±0.5% F.S. ±1digit
Power supply	Resistance	—	—	—	—	±0.5% F.S. ±1digit	±0.5% F.S. ±1digit
		DC6V (LR6 dry cell battery) AC adapter 100 ~ 240V 50/60Hz	AC adapter 100 ~ 240V 50/60Hz	AC adapter 100 ~ 240V 50/60Hz	DC6V (LR6 dry cell battery) AC adapter 100 ~ 240V 50/60Hz	AC adapter 100 ~ 240V 50/60Hz	AC adapter 100 ~ 240V 50/60Hz
Mass		approx. 1kg	approx. 1.1kg	approx. 1.1kg	approx. 1kg	approx. 1.1kg	approx. 1.1kg

D-50 series / ES-51 / OM-51 Specifications



		D-51	D-52	D-53	D-54	D-55	ES-51
		pH	pH ORP •RS-232C output (PC/Printer)	pH ORP ION •RS-232C output (PC/Printer)	pH ORP COND •RS-232C output (PC/Printer)	pH ORP DO •RS-232C output (PC/Printer)	COND SALT RESI •RS-232C output (PC/Printer)
Measurement method	pH	Glass electrode method	Glass electrode method	Glass electrode method	Glass electrode method	Glass electrode method	—
	ION	—	—	Ion electrode method	—	—	—
	Conductivity	—	—	—	AC bipolar method	—	AC bipolar method
	Dissolved Oxygen	—	—	—	—	Diaphragm galvanic battery method	—
	SALT	—	—	—	—	—	Conductivity conversion
	Resistance	—	—	—	—	—	Conductivity conversion
	Saturation Oxygen	—	—	—	—	—	—
Measurement range	Oxygen	—	—	—	—	—	—
	pH	pH0.00 ~ 14.00 Resolution 0.01pH	pH0.00 ~ 14.00 Resolution 0.01pH	pH0.00 ~ 14.00 Resolution 0.01pH	pH0.00 ~ 14.00 Resolution 0.01pH	pH0.00 ~ 14.00 Resolution 0.01pH	—
	Temperature	0.0 ~ 100.0°C Resolution 0.1°C	0.0 ~ 100.0°C Resolution 0.1°C	0.0 ~ 100.0°C Resolution 0.1°C	0.0 ~ 100.0°C Resolution 0.1°C	0.0 ~ 100.0°C Resolution 0.1°C	0.0 ~ 100.0°C Resolution 0.1°C
	mV(ORP)	—	-1999 ~ 1999 Resolution 1mV	-1999 ~ 1999 Resolution 1mV	-1999 ~ 1999 Resolution 1mV	-1999 ~ 1999 Resolution 1mV	—
	ION	—	—	0.0μ ~ 999g/L (mol/L)	—	—	—
	Conductivity	—	—	—	Cell constant 100m ⁻¹ : 0.000mS/m ~ 19.99S/m Cell constant 10m ⁻¹ : 0.0μS/m ~ 1.999S/m Cell constant 1000m ⁻¹ : 0.00mS/m ~ 199.9S/m Resolution 0.05% F.S.	—	Cell constant 100m ⁻¹ : 0.000mS/m ~ 19.99S/m Cell constant 10m ⁻¹ : 0.0μS/m ~ 1.999S/m Cell constant 1000m ⁻¹ : 0.00mS/m ~ 199.9S/m Resolution 0.05% F.S.
	Dissolved Oxygen	—	—	—	—	0.00 ~ 19.99mg/L Resolution 0.01mg/L	—
Resistance	—	—	—	—	—	Cell constant 100m ⁻¹ : 5.00Ω·m ~ 199.9kΩ·m Cell constant 10m ⁻¹ : 50.0Ω·m ~ 1.99MΩ·m Cell constant 1000m ⁻¹ : 0.500Ω·m ~ 19.99kΩ·m Resolution 0.05% F.S.	
Repeatability	SALT	—	—	—	—	—	0.00 ~ 4.00% Resolution 0.01%
	Saturation Oxygen	—	—	—	—	—	—
	Oxygen	—	—	—	—	—	—
	pH	±0.01pH ±1digit	±0.01pH ±1digit	±0.01pH ±1digit	±0.01pH ±1digit	±0.01pH ±1digit	—
	Temperature	±0.1°C ±1digit	±0.1°C ±1digit	±0.1°C ±1digit	±0.1°C ±1digit	±0.1°C ±1digit	±0.1°C ±1digit
Power supply	mV(ORP)	—	±1mV ±1digi	±1mV ±1digi	±1mV ±1digi	±1mV ±1digi	—
	ION	—	—	±0.5%F.S. ±1digit	—	—	—
	Conductivity	—	—	—	±0.5%F.S. ±1digit	—	±0.5%F.S. ±1digit
	Dissolved Oxygen	—	—	—	—	±0.1mg/L ±1digit	—
Resistance	—	—	—	—	—	±0.5%F.S. ±1digit	
Mass		DC3V (LR6 dry cell battery) Option: AC adapter	DC3V (LR6 dry cell battery) Option: AC adapter	DC3V (LR6 dry cell battery) Option: AC adapter	DC3V (LR6 dry cell battery) Option: AC adapter	DC3V (LR6 dry cell battery) Option: AC adapter	DC3V (LR6 dry cell battery) Option: AC adapter
		approx. 300g	approx. 300g	approx. 330g	approx. 330g	approx. 330g	approx. 300g

pH Electrode Line up

DS-51	DS-52
COND SALT RESI •RS-232C output (PC/Printer) •Battery operation possible	COND SALT RESI •RS-232C output (PC/Printer)
AC bipolar method	AC bipolar method
Conductivity conversion	Conductivity conversion
Conductivity conversion	Conductivity conversion
0.0 ~ 100.0°C Resolution 0.1°C	0.0 ~ 100.0°C Resolution 0.1°C
Cell constant 100m ⁻¹ : 0.000mS/m ~ 19.99S/m Cell constant 10m ⁻¹ : 0.0μS/m ~ 1.999S/m Cell constant 1000m ⁻¹ : 0.00mS/m ~ 199.9S/m Resolution 0.05% F.S.	Cell constant 100m ⁻¹ : 0.000mS/m ~ 19.99S/m Cell constant 10m ⁻¹ : 0.0μS/m ~ 1.999S/m Cell constant 1000m ⁻¹ : 0.00mS/m ~ 199.9S/m Resolution 0.05% F.S.
0.00 ~ 4.00% Resolution 0.01%	0.00 ~ 4.00% Resolution 0.01%
Cell constant 100m ⁻¹ : 0.05Ω·m ~ 199.9kΩ·m Cell constant 10m ⁻¹ : 0.5Ω·m ~ 1.999MΩ·m Cell constant 1000m ⁻¹ : 0.005Ω·m ~ 19.99kΩ·m Resolution 0.05% F.S.	Cell constant 100m ⁻¹ : 0.05Ω·m ~ 199.9kΩ·m Cell constant 10m ⁻¹ : 0.5Ω·m ~ 1.999MΩ·m Cell constant 1000m ⁻¹ : 0.005Ω·m ~ 19.99kΩ·m Resolution 0.05% F.S.
±0.5% F.S. ±1digit	±0.5% F.S. ±1digit
±0.5% F.S. ±1digit	±0.5% F.S. ±1digit
DC6V (LR6 dry cell battery) AC adapter 100 ~ 240V 50/60Hz approx. 1kg	AC adapter 100 ~ 240V 50/60Hz approx. 1.1kg

OM-51
DO •RS-232C output (PC/Printer)
Diaphragm galvanic battery method
Dissolved Oxygen conversion Dissolved Oxygen conversion
0.0 ~ 100.0°C Resolution 0.1°C
0.00 ~ 19.99mg/L Resolution 0.01mg/L
0.0 ~ 199.9% Resolution 0.1%
0.0 ~ 50.0% Resolution 0.1%
±0.1°C ±1digit
±0.1mg/L ±1digit
DC3V (LR6 dry cell battery) Option: AC adapter approx. 300g

Name	Model	Description	Temp.range(°C)	pH range	Part No. (Old No.)
3-in-1 electrode	9611-10D	Waterproof thick membrane type	0 ~ 80	0 ~ 14	3014046615(9096001800)
	9677-10D	Protein, high viscosity type	0 ~ 60	0 ~ 14	3014093086(9096002000)
	9669-10D	Precious, trace amount sample type	0 ~ 60	0 ~ 14	3014081109(9096001900)
	9621-10D	Plastic body	0 ~ 100※2	0 ~ 14	3014046613(9096001700)
	6367-10D	Sleeve※1	0 ~ 60	0 ~ 14	3014079136(9003011800)
	6378-10D	For test tubes※1	0 ~ 60	0 ~ 14	3014079140(9003011900)
	9678-10D	For test tubes	0 ~ 100※2	0 ~ 14	3100105299(9003018000)
	6252-10D	For food analysis※1	0 ~ 60	0 ~ 12	3014080850(9003013800)
	6066-10C	Standard	0 ~ 100	0 ~ 14	3014081105(9003013400)
	6069-10C	For extra-thin test tubes	0 ~ 60	0 ~ 14	3014081107(9003013500)
	6251-10C	Needle type	0 ~ 50	0 ~ 12	3014081805(9003013600)
	6261-10C	Flat type	0 ~ 50	0 ~ 12	3014081807(9003013700)
ISFET electrode	0030-10D	Needle type ISFET	0 ~ 60	0 ~ 14	3014028323(9096002100)
ORP electrode	9300-10D	Platinum 3-in-1 type	0 ~ 60	—	3014046710(9096000400)
Temperature electrode	4163-10T	For temperature compensation and measurement	0 ~ 100	—	3014080375(9003013000)

※1 Do not use this electrode with other electrodes, as it will interfere the measurement value. ※2 0-50°C when completely immersed.

Conductivity Electrode Line up

Electrode	Cell constant m ⁻¹ (cm ⁻¹)	Model	Range m ⁻¹ (cm ⁻¹)	Samples req'd(ml)	Temp. range(°C)	Part No. (Old No.)	
Conductivity electrode	Immersion type	10 (0.1)	3551-10D	10μS ~ 1S (0.1μS ~ 10mS)	50	0 ~ 60	3014081712(9056000800)
		100 (1)	9382-10D	0.1mS ~ 10S (1μS ~ 100mS)	20 ~ 30	0 ~ 80	3014046709(9096000300)
		100 (1)	3552-10D	0.1mS ~ 10S (1μS ~ 100mS)	15	0 ~ 100	3014081545(9056000900)
		1000 (10)	3553-10D	1mS ~ 100S (10μS ~ 1S)	50	0 ~ 60	3014081714(9056001000)
	Flow type	10 (0.1)	3561-10D	10μS ~ 1S (0.1μS ~ 10mS)	10	0 ~ 60	3014082350(9056001100)
		100 (1)	3562-10D	0.1mS ~ 10S (1μS ~ 100mS)	16	0 ~ 60	3014082513(9056001200)
		1000 (10)	3573-10C	1mS ~ 100S (10μS ~ 1S)	4	0 ~ 60	3014082590(9056001300)
		1000 (10)	3574-10C	1mS ~ 10S (10μS ~ 100mS)	0.25	0 ~ 60	3014082592(9056001400)

Ion Electrode Line up

Please be aware of the hindering ion and pH range interference of ion electrodes.

Electrode name	Model	Measuring range	Applicable reference electrode	Part No. (Old No.)
Cyanide ion electrode	8001-10C	0.03 ~ 2,600 ppmCN ⁻	2060A • 2565A	3014094393(9003015500)
Chloride ion electrode (Combination type)※	6560-10C	0.4 ~ 35,000 ppmCl ⁻	—	3014093430(9003014500)
Chloride ion electrode	8002-10C	0.4 ~ 35,000 ppmCl ⁻	2565A	3014094394(9003015600)
Sulfide ion electrode	8003-10C	0.3 ~ 32,000 ppmS ²⁻	2060A • 2565A	3014094395(9003015700)
Iodide ion electrode	8004-10C	0.01 ~ 13,000 ppmI ⁻	2060A • 2565A	3014094396(9003015800)
Bromide ion electrode	8005-10C	0.8 ~ 80,000 ppmBr ⁻	2565A	3014094397(9003015900)
Copper ion electrode	8006-10C	0.06 ~ 6,400 ppmCu ²⁺	2565A	3014094398(9003016000)
Cadmium ion electrode	8007-10C	0.1 ~ 11,000 ppmCd ²⁺	2060A • 2565A	3014094399(9003016100)
Lead ion electrode	8008-10C	2 ~ 20,000 ppmPb ²⁺	2565A	3014094400(9003016200)
Thiocyanate ion electrode	8009-10C	0.6 ~ 5,800 ppmSCN ⁻	2565A	3014094401(9003016300)
Fluoride ion electrode (Combination type)※	6561-10C	0.02 ~ 19,000 ppmF ⁻	—	3014093431(9003014600)
Fluoride ion electrode	8010-10C	0.02 ~ 19,000 ppmF ⁻	2060A • 2565A	3014093439(9003016400)
Silver ion electrode	8011-10C	0.01 ~ 110,000 ppmAg ⁺	2565A	3014094402(9003016500)
Ammonia electrode (Combination type)※	5002A-10C	0.1 ~ 1,000 ppmNH ₃	—	3014093560(9003016600)
Sodium ion electrode	1512A-10C	2.3 ~ 230,000 ppmNa ⁺	2565A	3014068526(9003016700)
Nitrate ion electrode (Combination type)※	6581-10C	0.62 ~ 62,000 ppmNO ₃ ⁻	—	3014093432(9003014700)
Nitrate ion electrode	8201-10C	0.62 ~ 62,000 ppmNO ₃ ⁻	2565A	3014094403(9003016800)
Potassium ion electrode (Combination type)※	6582-10C	0.04 ~ 39,000 ppmK ⁺	—	3014093433(9003014800)
Potassium ion electrode	8202-10C	0.04 ~ 39,000 ppmK ⁺	2565A	3014094404(9003016900)
Calcium ion electrode (Combination type)※	6583-10C	0.4 ~ 40,080 ppmCa ²⁺	—	3014093434(9003014900)
Calcium ion electrode	8203-10C	0.4 ~ 40,080 ppmCa ²⁺	2060A • 2565A	3014068839(9003017000)
Chloride ion tip	7660	—	—	3014093436(9003015000)
Fluoride ion tip	7661	—	—	3014093438(9003015100)
Nitrate ion tip	7681	—	—	3014068364(9003015200)
Potassium ion tip	7682	—	—	3014069795(9003015300)
Calcium ion tip	7683	—	—	3014068795(9003015400)
Ammonia electrode membrane (6pcs)	membrane(NH ₃)	—	—	3014067083(9012001000)

※ D-53 can use only combination type ion electrode.

DO electrode / DO Tip Line up

Electrode	Lead length	Model	Specification	Temp. range(°C)	Part No. (Old No.)
Waterproof DO electrode	2m	9551-20D	Field immersible type	0 ~ 40	3014047090(9096002300)
Waterproof DO electrode	10m	9551-100D	Field immersible type	0 ~ 40	3014047091(9096002400)
DO electrode	1m	9520-10D	Laboratory use	0 ~ 45	3014046711(9096000500)
DO tip	—	5401	Replacement electrode tip for 9551	—	3014072770(9003010000)
DO tip	—	7541	Replacement electrode tip for 9520	—	3014074145(9074000200)

Water Quality

MONITORING SYSTEM

W-20XD Series

**The W-20XD Series:
Same Innovative features,
now with Xtra Durable design**

- Heavy-duty stainless steel protective cover
- Rubber-made sensor guard to protect sensors and prevent contamination

Up to one month Data logging

"Simply leave the probe submerged in the sample and the sensor's built-in memory function enables continuous measurement for up to one month.* Personnel do not need to be present during the measurement process. Data can even be retrieved by personal computers in remote locations."

Simultaneous measurement of 13 parameters

With the W-23XD unit (only), simultaneous measurements of up to 13 parameters (from pH, dissolved oxygen, and conductivity to seawater specific gravity and a variety of ions)

can be obtained — much more quickly and easily than with conventional instruments. With its powerful measurement capabilities, the compact W-20XD series is recommended for all water quality researchers and professionals.

Measurement at depths as low as 100 meters

With its superior durability and high pressure resistance, the newly developed sensor facilitates measurements as far as 100 meters below the water surface. Thus, in addition to rivers, lakes and other shallow bodies, high-precision measurement can now be readily obtained — and water quality can be monitored — at dams, and even in the open sea.



▲ Control Unit

Multi-Probe ▶

● W-22XD sensor

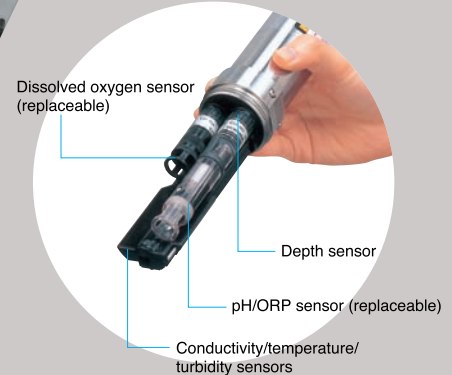

● W-23XD sensor

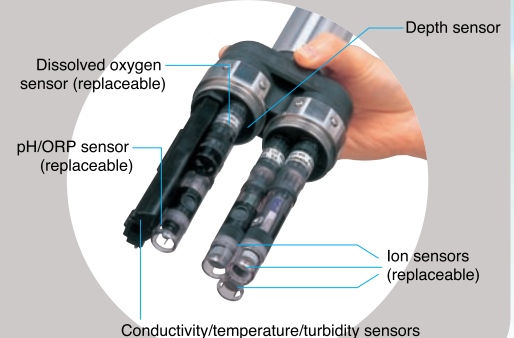

Measure and Display 11 Parameters Simultaneously with Innovative Features, Newly Designed Control Unit and Sensor Technology.

Intuitive software assures ease of use and operation efficiency. Experience the durability and performance of an instrument that exceeds your expectations in the field testing of ground water and surface water applications.

Measure and Display up to **11 Items** Simultaneously

Control Unit Features:

- Easy to read LCD Display
- One-hand operation
- On-screen icon displays battery power and GPS, USB and probe unit connectivity
- Quick-connect connector (cable to control unit)
- Shock resistant cover
- Backlight display

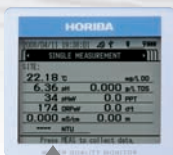

Operating instructions



Rugged Outdoor Design



Sensor Probe Unit Features:

- Ultra-sensitive Turbidity Sensor
- Minimum dissolved oxygen sensor maintenance with screw-on type membrane cap
- Chemical resistant materials of construction
- Optional ToupH pH electrode* that is difficult to break
- Field replaceable sensors



*Prevents damage during maintenance.

COMPACT pH METER

twin_{pH}
WATERPROOF

pH

Immersion, scoop, and flat measurement.



water proof

- B-211** single-point pH7 Auto Calibration NIST standard Solution
- B-212** Two point pH7/pH4 Auto Calibration NIST standard Solution
- B-213** Two point pH7/pH4 Auto Calibration US standard Solution

Measurement method	Glass electrode method
Measurement range	pH2 ~ 12
Repeatability	±0.1pH
Power supply	Two 3-volt lithium batteries
Mass	approx. 53g.

COMPACT CONDUCTIVITY METER

Twin Cond

COND SALT

Two measurement methods: drop the sample on the sensor or immerse the sensor in the sample.



B-173

Measurement method	AC bipolar method
Measurement range	Conductivity 0 ~ 19.9mS/cm
	SALT 0 ~ 1.1%
	Temperature 5 ~ 35°C
Repeatability	±1% full scale
Power supply	Two 3-volt lithium batteries
Mass	46g

COMPACT NITRATE ION METER

twin_{NO₃⁻}

ION NO₃⁻

HORIBA's flat sensor enables easy measurement with only a few drops of sample.

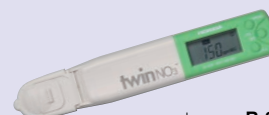

B-341 (for crops)

B-342 (for soil)

B-343 (for general use)

	B-341 (for crops)	B-342 (for soil)	B-343 (for general use)
Measurement method	Ion electrode method		
Measurement range	NO ₃ ⁻ 100 to 9900 (ppm or mg/L)	30 to 600 (ppm or mg/L)	62 to 6200 (ppm or mg/L)
	NO ₃ ⁻ -N 23 to 2200 (ppm or mg/L-N)	6.8 to 140 (ppm or mg/L-N)	14 to 1400 (ppm or mg/L-N)
	NO ₃ ⁻ -N※1	3.4 to 68 (kg/10a)	—
Repeatability	±10% ※2		
Power supply	CR2032 batteries (x2)		
Mass	Approx. 52g (meter only)		

※1 With soil/water sampling ratio of 1:5.
※2 Using HORIBA's prescribed method

CARDY Series

CARDY

ION

Compact SALT & ION meters



Na⁺ Ion meter

C-122 **Na⁺**

K⁺ Ion meter

C-131 **K⁺**

SALT meter

C-121 **NaCl**

	C-121/122 (NaCl/Na ⁺)	C-131 (K ⁺)
Measurement range	0.1%(w/w) ~ 10%(w/w) NaCl 23 ~ 2300ppm Na	39 ~ 3900ppm
Sample amount required	approx. 0.1ml	approx. 0.1ml
Sample temperature	5 ~ 35°C	5 ~ 35°C
Liquid junction	Porous macromolecule	Porous macromolecule
Mass	Approx. 40 g	

■ Dimensional Outlines Unit: mm(in)

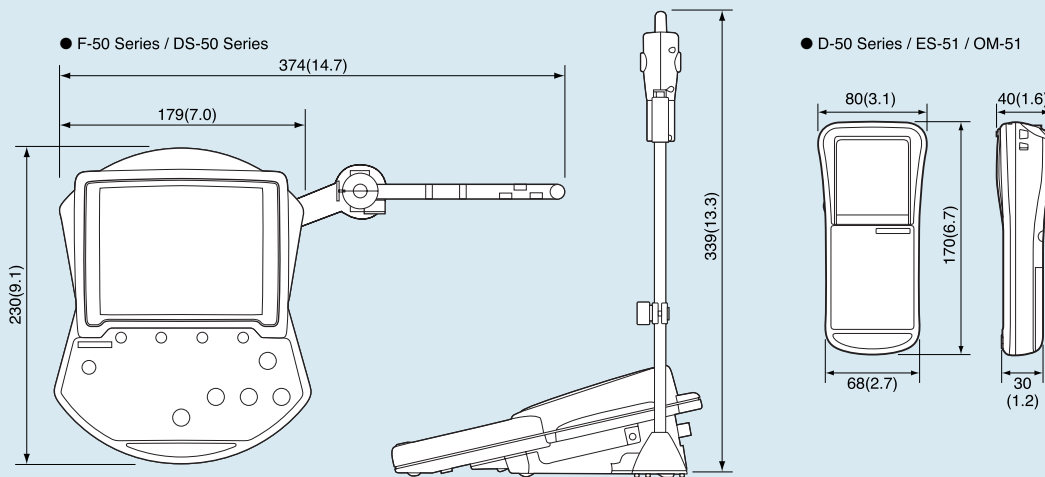

Horiba continues contributing to the preservation of the global environment through analysis and measuring technology.



Please read the operation manual before using this product to assure safe and proper handling of the product.

- The contents of this catalog are subject to change without prior notice, and without any subsequent liability to this company.
- The color of the actual products may differ from the color pictured in this catalog due to printing limitations.
- It is strictly forbidden to copy the content of this catalog in part or in full.
- All brand names, product names and service names in this catalog are trademarks or registered trademarks of their respective companies.

<http://www.horiba.com> e-mail: info@horiba.co.jp

● **HORIBA, Ltd.**

Head Office
Miyano Higashi, Kisshoin
Minami-ku, Kyoto, Japan
Phone: 81 (75) 313-8123
Fax: 81 (75) 321-5725

Tokyo Sales Office
1-7-8 Higashi-Kanda
Chiyoda-ku, Tokyo, Japan
Phone: 81 (3) 3861-8231
Fax: 81 (3) 3861-8259

TAIWAN Representative Office
3F, NO.18 Lane 676, Chung
Hua Rd, Chupei City,
Hsinchu Hsien, 302, Taiwan
Phone: 886 (3) 656-1012
Fax: 886 (3) 656-8231

● **HORIBA TRADING (SHANGHAI) CO., Ltd.**

Shanghai Office
Room 1701, United Plaza,
1468 Nanjing Rd. West,
Shanghai, 200040, China
Phone: 21-6289-6060
Fax: 21-6289-5553

Beijing Office
Room 1801, Capital Tower,
Beijing, Tower 1 No.6Jia,
Jianguomenwai Ave.,
Chaoyang District, Beijing,
100022 China
Phone: 10-8567-9966
Fax: 10-8567-9066

● **HORIBA KOREA Ltd.**

112-6 Sogong-Dong
Choong-ku, Seoul, Korea
Phone: 82 (2) 753-7911
Fax: 82 (2) 756-4972

● **HORIBA INSTRUMENTS Pte. LTD.**

10 Ubi Crescent
#05-11/12, Ubi Techpark
Singapore 408564
Phone: 65 6745-8300
Fax: 65 6745-8155

● **HORIBA INSTRUMENTS INCORPORATED**

Irvine Facility
17671 Armstrong Avenue
Irvine, CA 92614, U.S.A.
Phone: 1 (949) 250-4811
Fax: 1 (949) 250-0924

Ann Arbor Facility
5900 Hines Drive
Ann Arbor, MI 48108
U.S.A.
Phone: 1 (734) 213-6555
Fax: 1 (734) 213-6525

● **HORIBA / STEC INCORPORATED**

HORIBA Technology Center
3265 Scott Boulevard
Santa Clara, CA 95054
U.S.A.
Phone: 1 (408) 730-4772
Fax: 1 (408) 730-8975

● **HORIBA GmbH**

Kaplanstrasse 5
A-3430 Tulln,
Austria
Phone: 43 (2272) 65225
Fax: 43 (2272) 65230

HORIBA CZECHIA
Organizacni slozka Praha
Petrohradská 13
CZ-101 00 Praha 10, Czech Republic
Phone: 420 (2) 717-464-80
Fax: 420 (2) 717-470-64

● **HORIBA INSTRUMENTS LIMITED**

Kyoto Close
Summerhouse Road
Moulton Park, Northampton
NN3 6FL, U.K.
Phone: 44 (1604) 542500
Fax: 44 (1604) 542699

● **HORIBA EUROPE GmbH**

Head Office
Hans-Mess-Str.6
D-61440 Oberursel/Ts.
Germany
Phone: 49 (6172) 1396-0
Fax: 49 (6172) 137385

Leichlingen Facility
Julius-kronenberg Strasse
D-42799 Leichlingen
Germany
Phone: 49 (2175) 8978-0
Fax: 49 (2175) 8978-50

● **HORIBA SWEDEN**

Sydhamnsvägen 55-57,
SE-151 38 Södertälje,
Sweden
Phone: 46 (8) 550-80701
Fax: 46 (8) 550-80567

● **HORIBA FRANCE**

12, Avenue des Tropiques
91955 LES ULIS
France
Phone: 33 (1) 69-29-96-23
Fax: 33 (1) 69-29-95-77

● **HORIBA Jobin Yvon SRL Torino Office**

Europalace
Corso Torino 43/45
10043 Orbassano, Torino
Italy
Phone: 39 (011) 9040601
Fax: 39 (011) 9000448

Bulletin:HRE-0041E

Printed in Japan T-R(SK)23