

HORIBA

Explore the future

Multi-Component Gas Analyzer VA-3000 Series

Rack-Mounted Sample Gas Conditioning Systems VS-3000 Series

CO
CO₂
O₂
NO_x
SO₂
CH₄
N₂O

CO 100.0 ppm
CO₂ 15.00 vol%
O₂ 5.000 vol%

VA-3000

One analyzer for measurement of up to 3 gas components

3 in 1

HORIBA
VA-3000

NO_x 18.84 ppm
CO 181.8 ppm
O₂ 0.00 ppm

CE

CE marking compliance

IMS
HORIBA is operating Integrated Management System

ISO 9001
JQA-0298

ISO 14001
JQA-E-5008

ISO 13485
JQA-H0010

Explore the future

HORIBA

Provides true VERSATILITY

From environmental monitoring to developing new energy sources and chemicals for the new era, gas analysis systems are faced with needs and challenges that have changed dramatically over time. Responding to these new needs, HORIBA has developed the VA-3000, the versatile gas analyzer that's ready for the future. A single analyzer is now capable of measuring a wider selection of gas components utilizing many different types of sensor technology. Non-dispersive infrared (NDIR) modules are available to measure gases such as CO, CO₂, NO, N₂O, CH₄, SO₂ and others. A chemiluminescent sensor module may be included to measure NO or NO_x with a standard converter. And four different types of sensor modules are available to measure O₂ – galvanic, paramagnetic, zirconium oxide or magnetopneumatic. Designed to be compact and lightweight, the VA-3000 may have up to three sensor modules installed in a single analyzer case. This unique feature means the VA-3000 can be used today for a broad range of applications including research and development or environmental pollution monitoring, where efficiency and space-saving are crucial.

»» Use to measure the concentration of many different gases

A single VA/VS-3000 analyzer is capable of simultaneously measuring multiple gas components such as CO, CO₂, O₂, NO_x, SO₂, CH₄, N₂O and other gases. With the VS-3000 sampling system, the VA/VS-3000 will meet the needs of a diverse range of applications.

CO CO₂ NO_x SO₂ CH₄ N₂O O₂ and others

»» Many combinations of sensor modules are possible

Development of smaller sensor modules now makes it possible to install up to three sensor modules in a single unit. You can install three NDIR modules in a single case or substitute a chemiluminescent or oxygen module for any of the NDIR modules.

»» Wide selection of ranges and flexibility for many applications

The VA-3000 also features dynamic ranges up to 20x the base (first) range. And the dynamic range can be further expanded by installing multiple sensor modules for the same component gas in a single analyzer case. Now a single unit can perform measurements over a wide range from ppm to 100 percent concentrations. With our diversified lineup of modules, you can always choose the optimum range for your application.

»» High precision assured

The VA-3000 achieves repeatability of $\pm 0.5\%$ of F.S.R. (Full Scale Range), linearity of $\pm 1.0\%$ F.S.R., and drift of less than $\pm 2.0\%$ per week without requiring recalibration with a gas standard saving you money. For optimum precision, use the auto daily calibration feature, to virtually eliminate drift. Or specify the optional gas filled calibration cell that is used to routinely check and adjust the calibration of the NDIR modules without the need for external gas cylinders. With these features, high precision measurement is maintained throughout the entire measurement range.

»» Standard RS-232C interface makes data collection easy and remote operation possible

Analog outputs are also available for direct connection to control systems.

»» HORIBA provides reliable gas analysis systems

As an expert on gas analysis systems, with a wealth of experience, HORIBA can provide consulting services and/or appropriate hardware for pretreatment of even the most difficult sample gases.

3 in 1

One analyzer for measurement of up to 3 gas components

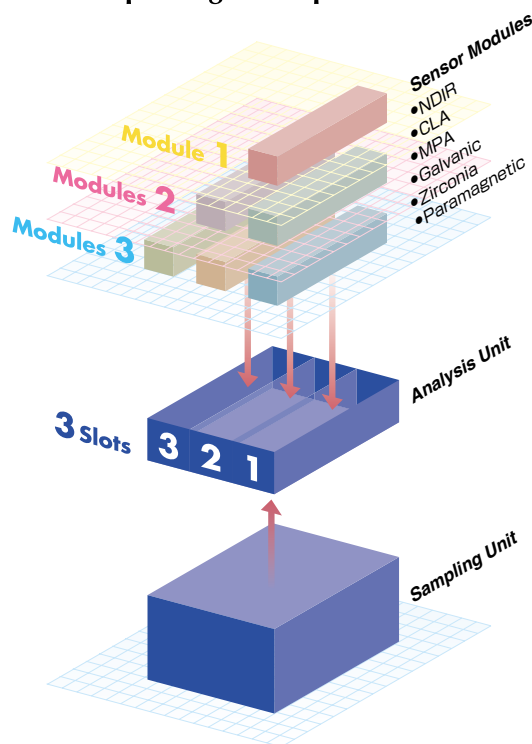

The VA-3000 and VS-3000 are UL/CSA approved.
UL Code No. UL60101A-1
CSA Code No. C22.2 No.1010.1
TÜV Pending

VA-3000 «« Analysis Unit

Determines gas concentrations.



»» VS-3000

Sampling Unit

Conditions sample gases that contain particulates, water vapor or acids prior to analysis.

Innovative new analysis technology

Some of the common gases measured

CO CO₂ SO₂
CH₄ N₂O

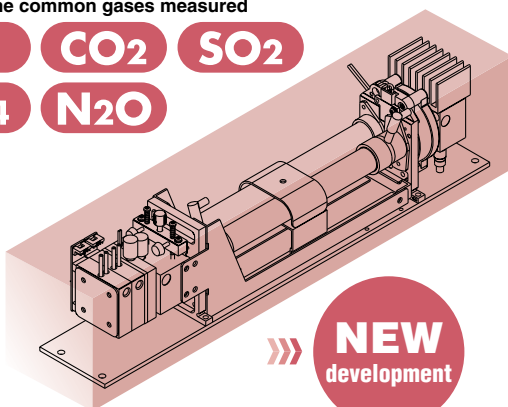

»» **NEW**
development

Results in compact size
and improved performance and reliability

New NDIR Sensor Module utilizing proprietary IR detector

NDIR Dual-beam Non-Dispersive Infrared Absorption Method

»» Able to measure many different gases accurately

As sample gas flows through the measurement cell, a beam of infrared energy (at a wavelength appropriate for the gas being measured) travels through the sample gas and strikes the infrared detector. The gas being measured absorbs infrared energy and reduces the energy reaching the IR detector. As a result the pressure of the gas in the first chamber of the detector is reduced causing gas to flow from this chamber to the other. This gas flow passes over the precision temperature sensor between the chambers and reduces the resistance value of the sensor element. Since the resistance value was previously calibrated relative to a specific gas concentration, the resistance value now measured can be displayed as a gas concentration reading for the sample gas. HORIBA's MEMS technology allows HORIBA to manufacture infrared (IR) temperature sensors that are very small yet very sensitive, highly reliable, and vibration-resistant. Since the IR sensors are very small, HORIBA can manufacture small, compact and lightweight sensor modules that have the same sensitivity and performance as the previous larger gas analyzer optical benches. This feature allows three analysis modules to fit into a single 19-inch rack case.

■ Newly developed pneumatic NDIR detector and patented chopper provide a number of new benefits



[Reduction of warm-up time]

The warm-up time required for the NDIR analysis module to reach full stability and performance has been substantially reduced to about 10 minutes (conventional NDIR analyzers need an hour or longer).

Measurement is now possible within minutes after power is turned on.



[Compact and light weight modules]

The small size and weight of each sensor module allows up to three to be installed in a single 19-inch rack mount case without sacrificing performance.

Now more instruments can be installed in less space.



[Virtually immune to vibration]

The proprietary HORIBA IR flow sensor in the VA-3000 series NDIR modules is not affected by external vibration because there are no moving parts in the detector. This allows stable and reliable measurement in a wide variety of locations and environments as well as mobile applications.



[Reliable noise free chopper]

The VA-3000 series incorporates HORIBA's patented axis-less chopper motor to maintain stable rotation. This assures that infrared energy passes through the measurement and reference cells precisely all the time. The chopper motor design virtually eliminates noise and extends the lifetime of the module significantly.

■ 3 modules in 1 case-compact analyzer creates new measurement possibilities



(Three modules can be easily installed in a 19-inch rack case)

Both the analysis unit and the sampling unit can be mounted in a standard 19-inch rack.

Up to three components can be simultaneously measured in a single analyzer unit. A broader range of gases can be measured in a smaller space.



(Small size makes the VA/VS-3000 ideal for bench top use)

Thanks to the small size, the VA/VS-3000 series analyzer and sampling conditioning system is ideal for use on a bench top in a crowded R&D lab.

(Multiple ranges of the same gas are possible)

Up to three of the same sensor modules (NDIR) can be installed in a single analyzer case. This expands the dynamic range that can be used to measure a gas.



■ Wide measurement ranges are provided for each module.

Measurement method	Component	Standard		Zero and span drift	Repeatability	Example of ranges (See Notes below)
		Minimum range	Maximum range			
NDIR	CO	0-200 ppm	0-100 vol%	±2.0% full scale per week	±0.5% of full scale	① 0-100/200/500/1000 ppm (CO ₂ , N ₂ O) ② 0-200/500/1000/2000 ppm (CO, CH ₄ , SO ₂) ③ 0-1000/2000/5000 ppm/1 vol% (CO, CO ₂ , CH ₄ , SO ₂) ④ 0-5/10/20/25 vol% (CO, CO ₂ , CH ₄) ⑤ 0-10/20/50/100 vol% (CO, CO ₂ , CH ₄)
	CO ₂	0-100 ppm	0-100 vol%	±2.0% full scale per week	±0.5% of full scale	
	N ₂ O	0-100 ppm	0-5000 ppm	±2.0% full scale per week	±0.5% of full scale	
	CH ₄	0-200 ppm	0-100 vol%	±2.0% full scale per week	±0.5% of full scale	
	SO ₂	0-200 ppm	0-10 vol%	±2.0% full scale per week	±0.5% of full scale	
CLA	NO _x	0-20 ppm	0-5000 ppm	±2.0% full scale per week	±0.5% of full scale (±1.0% for 0-100 ppm)	① 0-20/50/100/200/500/1000/2000 ppm ② 0-50/100/200/500/1000/2000/5000 ppm
MPA	O ₂	0-5 vol%	0-100 vol%	±2.0% full scale per week	±0.5% of full scale	① 0-5/10/25 vol% ② 0-10/20/50 vol%
Galvanic	O ₂	0-5 vol%	0-25 vol%	±1.0% full scale per day	±0.5% of full scale	0-5/10/25 vol%
Zirconia	O ₂	0-5 vol%	0-25 vol%	±2.0% full scale per week	±0.5% of full scale	0-5/10/25 vol%
Paramagnetic	O ₂	0-5 vol%	0-25 vol%	±1.0% full scale per week	±0.5% of full scale	0-5/10/25 vol%

Note 1: Select the lowest range and maximum range ratio within the above concentration ranges according to the following conditions. [NDIR] 4 ranges with a maximum ratio between the lowest and highest range (range ratio) of 10x (or 20x as an option, although this may be limited by the cell length). [CLA] 8 ranges with a maximum range ratio of 100x (if the maximum range exceeds 2000ppm, the minimum range should be 50ppm or more).

Note 2: Contact us if you require any ranges below the concentration ranges noted above.

Note 3: Contact us if you require measurement of special gases such as NH₃.

CO 100.00ppm
 CO₂ 15.00vol%
 O₂ 5.000vol%

Many combinations of different sensor modules provides greater flexibility

The free combination of measurement modules utilizing different technologies to measure many different gases makes the VA-3000 series truly applicable to the diverse needs of gas analysis for process control, environmental monitoring or R&D testing. The available modules include non-dispersive infra-red (NDIR) sensors that utilize HORIBA's proprietary NDIR detector to measure a wide variety of gases; a sensor module utilizing the proprietary interference free chemiluminescent (CLA) method allows low-concentrations of NO (or NO_x using an NO₂ converter) to be measured; and sensor modules utilizing four different measurement methods for oxygen (O₂) are available.

NO_x

The NO_x analysis module uses the sensitive chemiluminescence method (CLA) which permits NO_x measurements in a range as low as 0–10 ppm. The chemiluminescence analyzer has virtually zero Interference. HORIBA design technology and experience have virtually eliminated CO₂ quenching and water vapor Interference; operates at atmospheric pressure.

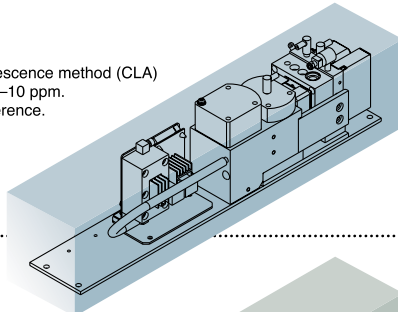

Measurement principle **Chemiluminescence**

» Virtually zero interference from CO₂ and water vapor; very stable

O₂

Choose from four analysis methods for the oxygen analyzer module. Select the sensor module based on your specific requirements and sample gas conditions.

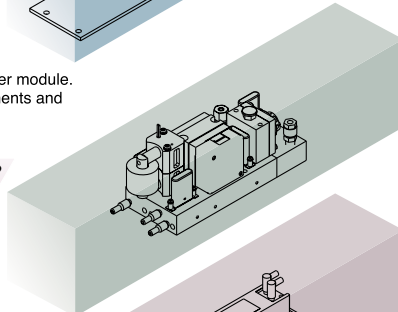

Measurement principle **Magnetopneumatic**

» Highly accurate and stable measurement unaffected by coexisting gases or external vibration

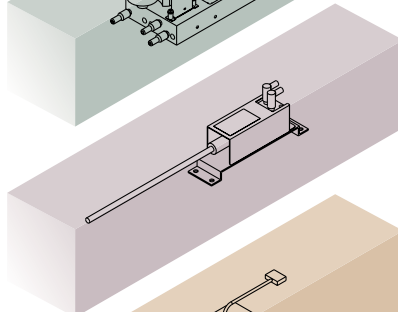

Measurement principle **Zirconia**

» Stable measurement unaffected by environmental conditions

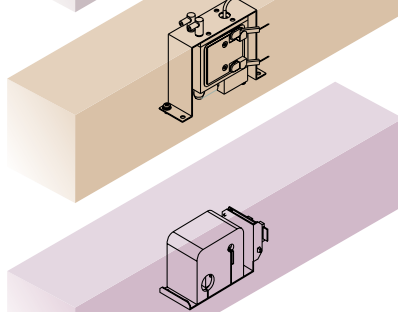

Measurement principle **Galvanic**

» Stable measurement with a compact and lightweight sensor

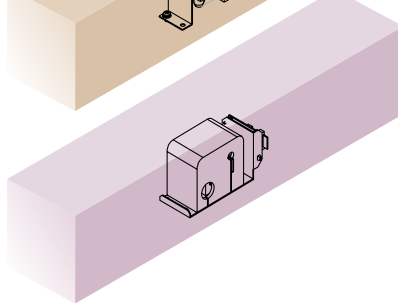

Measurement principle **Paramagnetic**

» Highly accurate and stable measurement without carrier gas

- Performance**
 - Stability by design
 - Low-concentration gas is measured
 - Warm-up and startup performance is important
- Sample gas condition**
 - Flammable gas is also present
 - High-concentration acidic gas is also present
 - Alkaline gas is also present
 - Water in a liquid state may be contained in the gas
 - Sample flow rate should be minimized
- Installation environment**
 - Carrier gas is not available
 - VS-3000 sample conditioning system is not used
 - Back pressure exists
 - Installation environment is vibrating
- Cost and other points**
 - Operating costs should be minimized
 - Maintenance should be minimized

	MPA	Zirconia	Galvanic	Paramagnetic
Performance	⊙	⊙	○	○
Sample gas condition	⊙	○	○	○
Installation environment	○	○	○	○
Cost and other points	○	○	○	○

⊙ Best
○ Can be used

Easy operation from the front panel

A large liquid crystal panel and numeric keypad make it easier than ever to operate the VA-3000. Designed as an interactive system, basic operations are performed on the front panel. With the clear and sharp display, an operator can set parameters and check data on the display using easy push button operations.



Up to the three components can be measured simultaneously with a single analyzer.

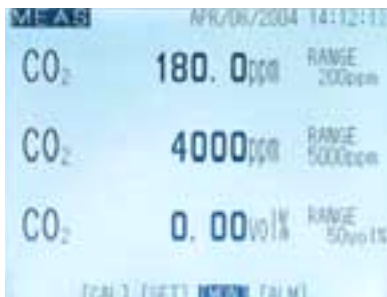

Measure a wide range of the same gas using two sensor modules.

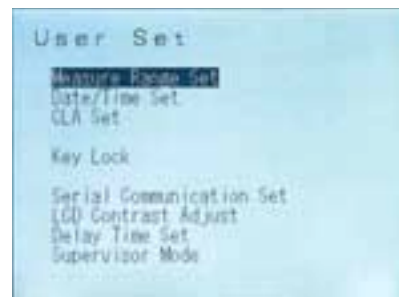

Setting measurement parameters is simple with a push of a button on the front panel.

■ The free combination of modules and sampling units can satisfy diverse measurement needs.

	Model	See Note below						O ₂			Sampling Unit			
		CO	CO ₂	SO ₂	CH ₄	N ₂ O	NO _x	Galvanic	Zirconia	Paramagnetic	VS-3001	VS-3002	VS-3003	VS-3004
	Analysis unit	NDIR	NDIR	NDIR	CLA	MPA	Galvanic	Zirconia	Paramagnetic					
Module 1	3001	●								●				
	3002				●							●		
	3003					●				●				
	3004						●			●				
	3005							●		●				
	3006								●	●				
Module 2	3011	●	●							●				
	3012		●		●							●		
	3013	●				●				●				
	3014	●					●			●				
	3015	●						●		●				
	3016	●							●	●				
	3023				●	●							●	
	3024				●		●					●		
	3025				●			●				●		
	3026				●				●			●		
Module 3	3111	●	●	●						●				
	3113	●	●			●				●				
	3114	●	●				●			●				
	3115	●	●					●		●				
	3116	●	●						●	●				
	3123	●			●	●							●	
	3124	●			●		●					●		
	3125	●			●			●				●		
3126	●			●				●			●			

Note: Modules to measure other gases are available.

■ VS-300X Standard Sampling Units

Four different sampling units are available in 19-inch rack mount cases to meet the requirements of the different combinations of modules. The basic sampling unit (VS-3001) provides the pumps, filters, thermo-electric cooler, flow-meters and other components required to clean, dry and regulate the flow of sample gas to the analyzer modules. Any of the four sampling units may be used with the NDIR modules; however, the CLA and MPA modules require additional components for proper operation. The sampling units for use with the CLA module include an NO₂ converter and a pump, flow-meter and conditioning components to provide clean air to the ozone generator in the CLA module.

The sampling units for use with the MPA module include a pump, filter and buffer tank required to maintain a vacuum on the MPA detector chamber. Refer to the chart above to select the proper VS-300X unit to use with the VA-3000 instrument you have configured and refer to the schematics on page 8 for the flow diagrams for each sampling unit. If a user assembles their own sample system, the requirements for these instruments must be considered. HORIBA also provides kits containing the additional components required to support the CLA and MPA modules.

CO 100.00
CO₂ 15.00
O₂ 5.000

Many Output and Communication Options are available. To Facilitate Data Collections and Remote Operation.

●Analog Outputs:

Two Analog outputs for each component measured by the VA-3000 are available through a DB15 connector on the rear panel of the instrument. Each output may be set to either 4 to 20mA or 0 to 1Vdc non-isolated. If an O₂ measurement module is included in the instrument, separate outputs may be configured by the user for the raw and O₂ corrected values.

●Discrete I/O options:

The optional VA-PIO-01 board provides 16 channels of digital inputs and 16 channels of digital outputs. The inputs require an external dry contact closure from the users control system (some commands require momentary closures) and the outputs are form C dry contacts rated 24V DC, 0.5A. The following functions are provided by the optional VA-PIO-01 circuit board via three DB25 connectors on the rear panel:

Analyzer Alarm:

Activated when diagnostic values monitored in each analyzer module are abnormal including module temperature, chopper motor failure and low sample flow-rate. The alarm activates when the temperature is outside the range of 10 to 70° C. When NDIR modules are installed, the alarm is active if the movement of the chopper motor becomes abnormal or stops. If the flow sensor option is installed, the alarm is active if the gas flow in sample or calibration mode is too low. All alarms are identified on the LCD display. See the operator manual for a complete list of alarm conditions for each analyzer module.

Calibration Alarm:

Active when a zero calibration exceeds +/-50% of the maximum full scale range or when a span value is less than 0.60 or greater than 1.30 times the initial span adjustment. Initial adjustments are the values recorded during the analyzer set-up by service personnel. Other conditions may also activate this alarm. Refer to the service manual for details.

In Calibration:

Active when the instrument is placed in the calibration mode either manually from the front panel or remotely via one of the instrument communication modes.

Range Identification:

A combination of two or three contact outputs allows identification of up to four ranges and a third contact will identify up to eight ranges using BCD logic. There is one set of contacts for each analyzer module. Single range configuration is standard for all analyzer modules; additional ranges are optional.

Concentration Alarm:

The instrument software allows the user to set an alarm for the concentration measured on each channel. These may be set at a Low level or a High level.

Remote Range Change:

Allows the user to remotely select any of the configured ranges on the analyzer modules. Depending on the number of ranges, this function requires two or three contact inputs per analyzer module.

Output Hold:

Allows the user to request the instrument to hold the analog outputs at the current value when the instrument is put into calibration mode.

Zero Calibration Request:

Allows the user to remotely put the instrument into zero calibration mode. All modules zero simultaneously.

Span Calibration Request:

Allows the user to remotely put the instrument into span calibration mode individually by module.

●Serial communication function

Serial communication is available through two RS-232 serial ports with DB9 connectors on the rear panel. The first RS-232 port is configured to communicate using HORIBA's generic communication protocol. The commands for the HORIBA generic protocol are available for customer use on request. This port is used by HORIBA service personnel to set-up and service the instrument. It also connects to the optional HORIBA data collection software package. The second serial port can be easily converted to RS-485 and is available for data collection by customer-supplied software. This port communicates via the optional Modbus protocol.

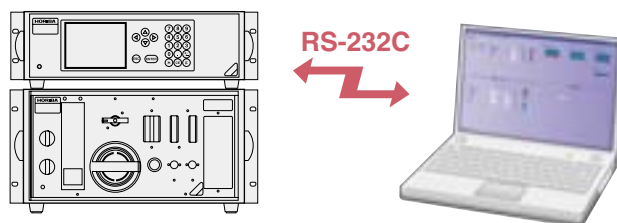

●Optional HORIBA data collection software facilitates remote data management from your computer

The optional HORIBA data collection software allows you to transfer the data to your computer using the HORIBA protocol. The software is similar to an electronic strip chart recorder. The data is displayed in graphical form and saved as a CSV format file and accessed via standard spreadsheet software such as Microsoft Excel®.



●MODBUS and Ethernet Protocols optional

There are three methods of customer communication with the VA-3000:

1. Connect using the optional HORIBA data collection software program.
2. Develop a program to communicate using the HORIBA protocol.
3. Connect using a customer supplied program which communicates using a Modbus protocol. The Modbus protocol in the VA-3000 is optional.

Ethernet (TCP/IP) communication is available for the Modbus option. All Modbus functions are available through an optional Ethernet connection on the rear panel of the analyzer.

Wide Variety of Standard Features and Functions as well as Optional Features. Allow the VA-3000 to be Configured to Meet the Requirements of Any Application.

●Standard functions configured prior to shipment include:

Output:

Select 0-1VDC or 4-20 mA for each of two channels per module

Communication Ports:

One of two RS-232 may be changed to RS-485

Automatic Calibration:

Activate this function to allow the instrument to reset the zero and span calibrations when the instrument is manually or remotely put in the calibrate mode.

Select Automatic Range Change:

Allows the user to set a point where the analyzer will automatically change from the measurement range it is currently on to the next highest or lowest range available in the analyzer module depending on whether the measured concentration is increasing or decreasing.

Select Negative Display:

Negative measurement value means you will never see any value on the screen less than 0.000.

Select O₂ Correction:

If an O₂ module is installed in the instrument case with other modules such as CO and NO_x and if this function is activated, the measured values for CO and NO_x will be corrected for dilution based on the measured O₂ concentration in accordance with US EPA procedures. The instrument will have analog and digital (if communication options are installed) outputs for both the raw CO and NO_x values as measured and the corrected values.

Select the Concentration HOLD Function:

If this function is activated, when the instrument is put into the zero or span calibration mode, the concentration values indicated at the analog outputs and any digital outputs (if additional communications options are installed) will be held at the concentration value last measured before the instrument mode was changed.

Set Alarms for the Gas Concentration:

There are two alarm points that can be set for each analyzer module. These can be set to alarm at a Low (zero) and a High value, or at a High and a Higher value. The alarm will show on the instrument front panel screen and will transmit information via the RS-232 port and if the optional PIO board is installed, contact closures are also available.

Select Memory of Calibration and Alarm History:

The processor in the instrument stores the zero and span calibration coefficients for each module installed in the case for 15 days. This information can be displayed on the front panel to indicate if there is a significant trend in calibration shift that would indicate that there might be a problem with the analyzer module. The processor also stores the last 30 analyzer alarms that occurred for each module installed in the case. This information can be displayed on the front panel.

Alarms recorded include:

Zero/ Span Calibration alarm, Cell Temperature and Chopper alarm for NDIR, Detector Temperature alarm for CLD module.

●Other Optional Features:

Atmospheric Pressure Correction:

The pressure compensation function corrects the output signal from the NDIR and MPA O₂ modules for changes in sensitivity caused by changes in the atmospheric pressure since the instrument was last calibrated with a cylinder calibration gas. Galvanic, PMA and Zirconia O₂ modules and the CLD module do not have pressure compensation. This option is useful if you desire the best possible accuracy over a period of time when you will not calibrate the instrument with cylinder gas.

Flow Rate Display:

A miniature mass flow meter is installed to monitor the flow rate of gas through the instrument. The flow rate is displayed on the front panel and if the flow rate deviates from a preset value an alarm will be displayed on the front panel and, if the VA-PIO-01 board or other communication options are installed, will be transmitted external to the instrument.

Stainless Steel Tubing with Swaglok Fittings

Stainless Steel Tubing and Swaglok Fittings can be provided as an option when the instrument is initially delivered. This option cannot be easily added at a later date. This option is not available for the CLD or O₂ analyzer modules at this time.

Separate Gas Inlet Fittings per Module:

In the standard instrument, gas flows to the three modules sequentially in series. As an option HORIBA can make separate gas inlet connections for each module with a common exhaust; however, the software is designed so that all three modules will be in the zero calibration mode simultaneously and this cannot be changed. The span calibration may be done separately.

Gas Connections on the Front Panel:

The gas connections can be moved from the rear of the case to the front panel but if this is done then only two analyzer modules will fit into the standard VA-3000 case.

Specifications

VA-3000 (analysis Unit) Specifications			NDIR *1	CLA	Magnetopneumatic Oxygen Analysis	Galvanic	Zirconia *2	Paramagnetic
Performance	Linearity	Range Ratio $\leq 10x$	$\pm 1.0\%$ of full scale	$\pm 1.0\%$ of full scale	$\pm 1.0\%$ of full scale			
		Range Ratio $> 10x \leq 20x$	$\pm 1.5\%$ of full scale					
	Drift	Zero Span	$\pm 2.0\%$ full scale per week		$\pm 2.0\%$ full scale per week	$\pm 1.0\%$ full scale per day	$\pm 2.0\%$ full scale per week	$\pm 1.0\%$ full scale per week
		Response time	From the inlet of analyzer (for measurement of single component)	T90 within 30 seconds T95 within 45 seconds		T90 within 30 seconds T95 within 45 seconds		
	Warm-up time		Approx. 20 minutes	Approx. 60 minutes	Approx. 60 minutes	Approx. 20 minutes	Approx. 40 minutes	Approx. 20 minutes
Input/Output	Analog outputs		DC 0 to 1 V (Non-isolated output), or DC 4 to 20 mA (Non-isolated output); Two per modules					
	Serial communication		Two RS-232C ports; additional RS-485 port. And MODBUS or Ethernet Protocols are optional.					
Measuring gas condition	Flow rate		Approx. 0.5L/min					
	Sample condition		Temperature: Ambient temperature, Water: Saturated at 5°C or less, Pressure: 490Pa (4.9kPa for the analyzer including CLA), No dust, Corrosive, flammable, and explosive gases are not allowed					
	Gas connections		1/4 F NPT except exhaust is 1/4 tube; can be optionally installed on front panel; a single gas inlet is provided standard; the gas flows sequentially from one module to the next; as an option separate gas inlets can be provided for each module.					
	Gas Tubing		Teflon; 316 stainless steel optional					
Installation	Environment conditions *3		Temperature: 0 to 40°C, Relative humidity: 90% or less					
Power supply		AC 100 to 120 V or AC 200 to 240 V, 50/60Hz, (Voltage should be specified)						
Power consumption		Approx. 200VA for one NDIR module to 300VA for three modules						
Display		LCD 118.18 mm (W) x 89.38 (H), 320 dots (W) x 240 dots (H)						
Case		19-inch panel mount (Standard)						
Exterior dimensions		430 mm (W) x 132 mm (H) x 550 mm (D)						
Weight		Approx. 20kg (Approx. 44 lbs) for three modules in one analyzer unit						

*1 When using the NDIR nitrous oxide (N₂O) analyzer, an inline catalytic converter must be used if the sample gas contains more than 10 percent carbon monoxide (CO).
 *2 When using the zirconia oxygen (O₂) analyzer and the sample gas contains reducing gases (carbon monoxide (CO), total hydrocarbons (THC), and/or hydrogen (H₂)), to prevent rapid deterioration of the zirconia sensor, the coexisting oxygen and water vapor concentrations must exceed the total concentration of the reducing gases. The sample gas must meet this requirement: Reducing gas + H₂ < H₂O + O₂.

Types of reducing gas: **CO H₂ THC**
 Allowable concentrations: CO <5000 ppm, H₂ <1000 ppm. When THC is included, CO + H₂ < H₂O + O₂.
 Example 1: **THC** + **CO** + **H₂** < **H₂O** + **O₂**
 1000 ppm + 2000 ppm + 1000 ppm < 8000 ppm + 1000 ppm (acceptable)
 Example 2: **THC** + **CO** + **H₂** > **H₂O** + **O₂**
 5000 ppm + 4000 ppm + 1000 ppm > 8000 ppm + 1000 ppm (unacceptable)

When reducing gases are present in the sample gas an oxidation reaction may take place in the sample resulting in degraded measurement accuracy.
 *3 When using the NDIR carbon dioxide (CO₂) analyzer, assure that the background concentration of CO₂ in the operating environment is stable.

VS-3000 (sampling Unit) Specifications				
Model	VS-3001	VS-3002	VS-3003	VS-3004
Application	For NDIR, Galvanic, Zirconia and PMA	For NDIR, Galvanic, Zirconia, MPA and PMA	For NDIR, Galvanic, Zirconia, PMA and CLA	For NDIR, Galvanic, Zirconia, PMA, MPA and CLA
Form	19-inch panel mount			
Sampling method	5°C sampling			
Material of exhaust gas section	Stainless steel, PP, PVC, PVDF, PTFE, FKM, CR and Glass			
Sampling volume	1.5 to 5.0L/min			
Power supply	100 - 120 V AC or 200 - 240 V AC, 50/60 Hz (specify voltage)			
Power consumption	Approx. 250 VA	Approx. 300 VA	Approx. 450 VA	Approx. 450 VA
Dimensions	430 mm (W) x 221 mm (H) x 550 mm (D)			
Weight	Approx. 14 kg	Approx. 16 kg	Approx. 19 kg	Approx. 20 kg
Sample handling	Sample inlet: $\phi 8/6$ Teflon pipe joint, Sample outlet: $\phi 8/6$ Hose end, Calibration gas inlet: Rc 1/8($\phi 6/4$ Teflon pipe joint), Bypass outlet: $\phi 8/6$ Hose end			
Sample gas condition	Explosive, combustible, or corrosive gases not permitted. SO ₃ : 50ppm or less, NO ₂ : 6ppm or less, Dust: 0.1mg/m ³ or less, Temperature: ambient, Water vapor: saturation at 60°C or less, Pressure: ± 980 Pa			

Dimensional Outlines

Mounting brackets (e.g., slide rails, rack mounting plates) are optional.

Unit: mm (in)

VA-3000
(Analyzer Unit)

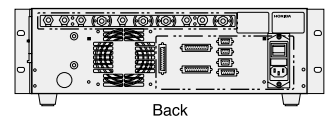
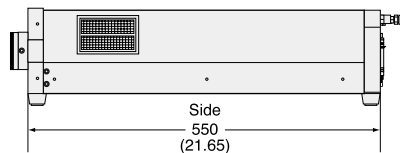
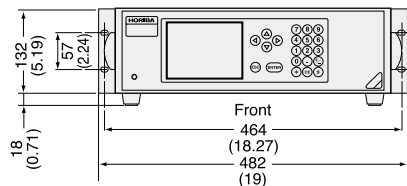

VS-3000
(Sampling Unit)

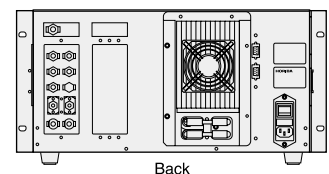
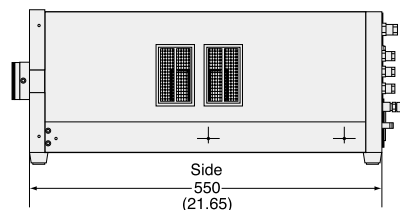
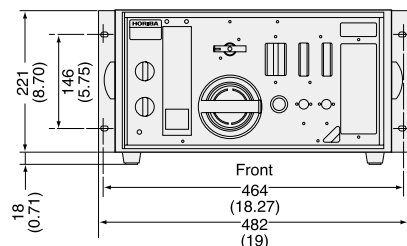

Flow sheet

LEGEND

- GC : Gas Cylinder
- DS : Water Drain Separator
- MC : Acid Mist Catcher
- SC : Manual Valve
- F : Filter
- P : Pump
- C : Thermo-electric cooler
- FM : Flow Meter
- CAP : Capillary
- NV : Needle Valve
- BT : Buffer Tank
- R : Pressure Regulator
- A : Analyzer module
- OGU : Ozone Generator
- SCR : Scrubber
- DO : Deozonator
- COM: NO_x Converter
- SV : Solenoid Valve

VA-3000 + VS-3001

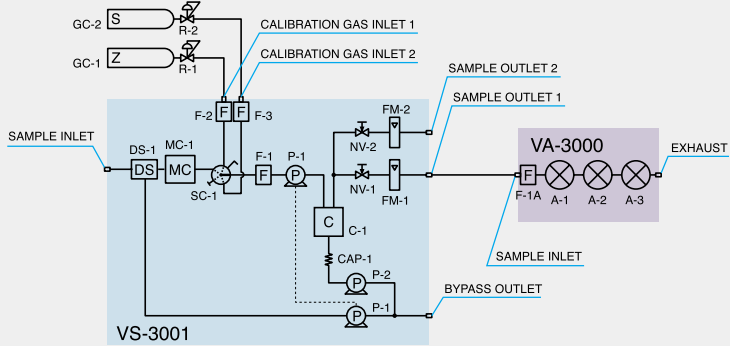

VA-3000 + VS-3002

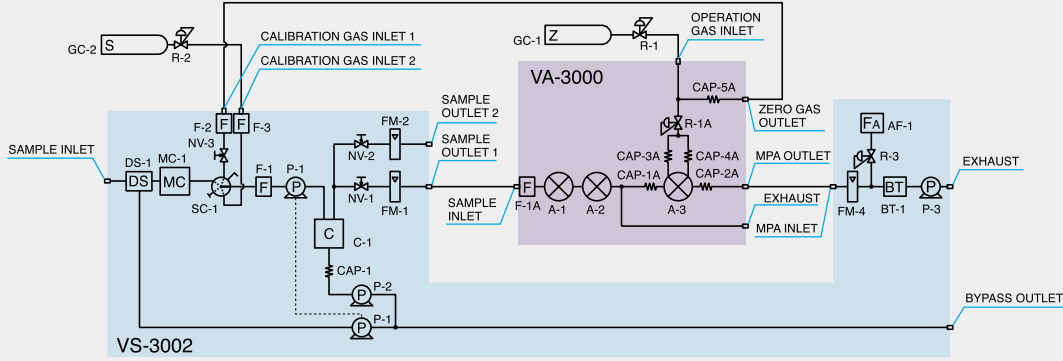

VA-3000 + VS-3003

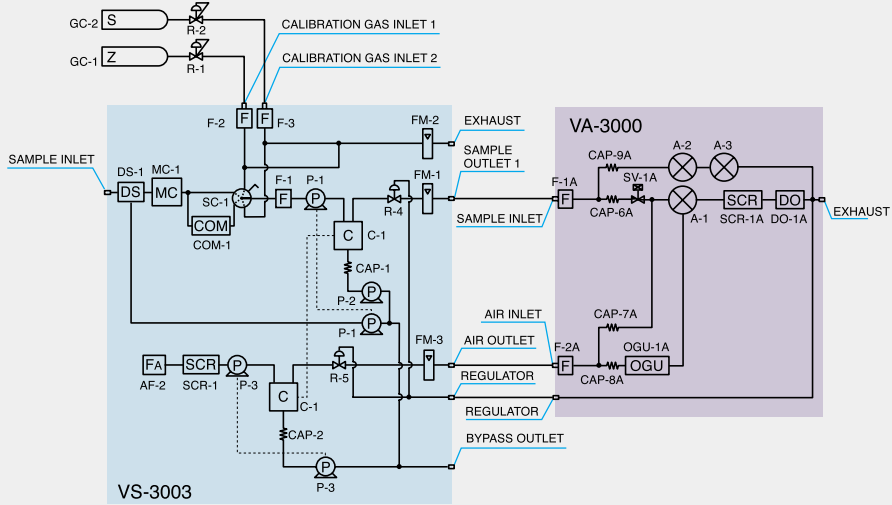

VA-3000 + VS-3004

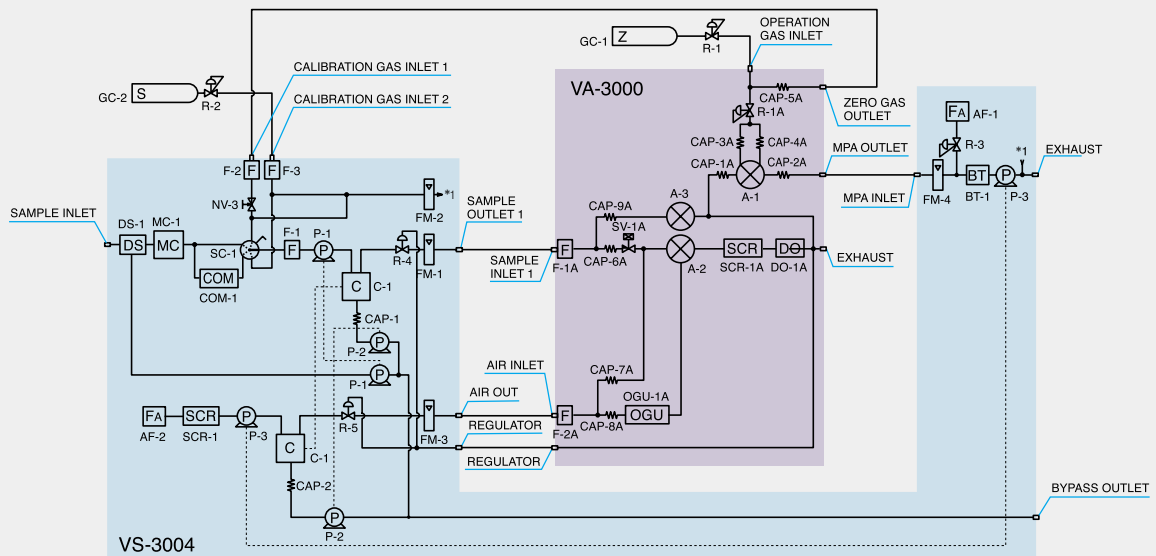

HORIBA continues contributing to the preservation of the global environment through analysis and measuring technology.



Please read the operation manual before using this product to assure safe and proper handling of the product.

- The contents of this catalog are subject to change without prior notice, and without any subsequent liability to this company.
- The color of the actual products may differ from the color pictured in this catalog due to printing limitations.
- It is strictly forbidden to copy the content of this catalog in part or in full.
- All brand names, product names and service names in this catalog are trademarks or registered trademarks of their respective companies.

<http://www.horiba.com> e-mail: info@horiba.co.jp

● **HORIBA, Ltd.**

Head Office
Miyano Higashi, Kisshoin
Minami-ku, Kyoto, Japan
Phone: 81 (75) 313-8123
Fax: 81 (75) 321-5725

Tokyo Sales Office
1-7-8 Higashi-Kanda
Chiyoda-ku, Tokyo, Japan
Phone: 81 (3) 3861-8231
Fax: 81 (3) 3861-8259

● **HORIBA TRADING (SHANGHAI) CO., Ltd.**

Shanghai Office
Room 1701, United Plaza,
1468 Nanjing Rd. West,
Shanghai, 200040, China
Phone: 21-6289-6060
Fax: 21-6289-5553

Beijing Office
Room 1801, Capital Tower Beijing,
Tower 1 No.6Jia, Jianguomenwai Ave.,
Chaoyang District, Beijing,
100022 China
Phone: 10-8567-9966
Fax: 10-8567-9066

● **HORIBA KOREA Ltd.**

112-6 Sogong-Dong
Choong-ku, Seoul, Korea
Phone: 82 (2) 753-7911
Fax: 82 (2) 756-4972

● **HORIBA INSTRUMENTS Pte. LTD.**

10 Ubi Crescent
#05-11/12, Ubi Techpark
Singapore 408564
Phone: 65 6745-8300
Fax: 65 6745-8155

● **HORIBA INSTRUMENTS INCORPORATED Irvine Facility**

17671 Armstrong Avenue
Irvine, CA 92614, U.S.A.
Phone: 1 (949) 250-4811
Fax: 1 (949) 250-0924

● **HORIBA GmbH**

Kaplanstrasse 5
A-3430 Tulln,
Austria
Phone: 43 (2272) 65225
Fax: 43 (2272) 65230

HORIBA CZECHIA
Organizacni slozka Praha
Petrohradská 13
CZ-101 00 Praha 10, Czech Republic
Phone: 420 (2) 717-464-80
Fax: 420 (2) 717-470-64

● **HORIBA INSTRUMENTS LIMITED**

Kyoto Close
Summerhouse Road
Moulton Park, Northampton
NN3 6FL, U.K.
Phone: 44 (1604) 542500
Fax: 44 (1604) 542699

● **HORIBA EUROPE GmbH**

Head Office
Hans-Mess-Str.6
D-61440 Oberursel/Ts.
Germany
Phone: 49 (6172) 1396-0
Fax: 49 (6172) 137385

Leichlingen Facility
Julius-kronenberg Strasse
D-42799 Leichlingen
Germany
Phone: 49 (2175) 8978-0
Fax: 49 (2175) 8978-50

● **HORIBA FRANCE**

12, Avenue des Tropiques
91955 LES ULIS
France
Phone: 33 (1) 69-29-96-23
Fax: 33 (1) 69-29-95-77

Bulletin:HRE-2854C

Printed in Japan ZY-F(SK)33