

HORIBA

EXPANSION KIT

(For IT-550) CODE : I1000153000

INSTRUCTION MANUAL

Before using the INFRARED THERMOMETER,
thoroughly read this manual for the proper operation.
After reading, keep this manual for future reference.

Unauthorized copying and reproduction of
this Instruction Manual is forbidden.

© Copyright HORIBA, Ltd. 1999

Printed in Japan

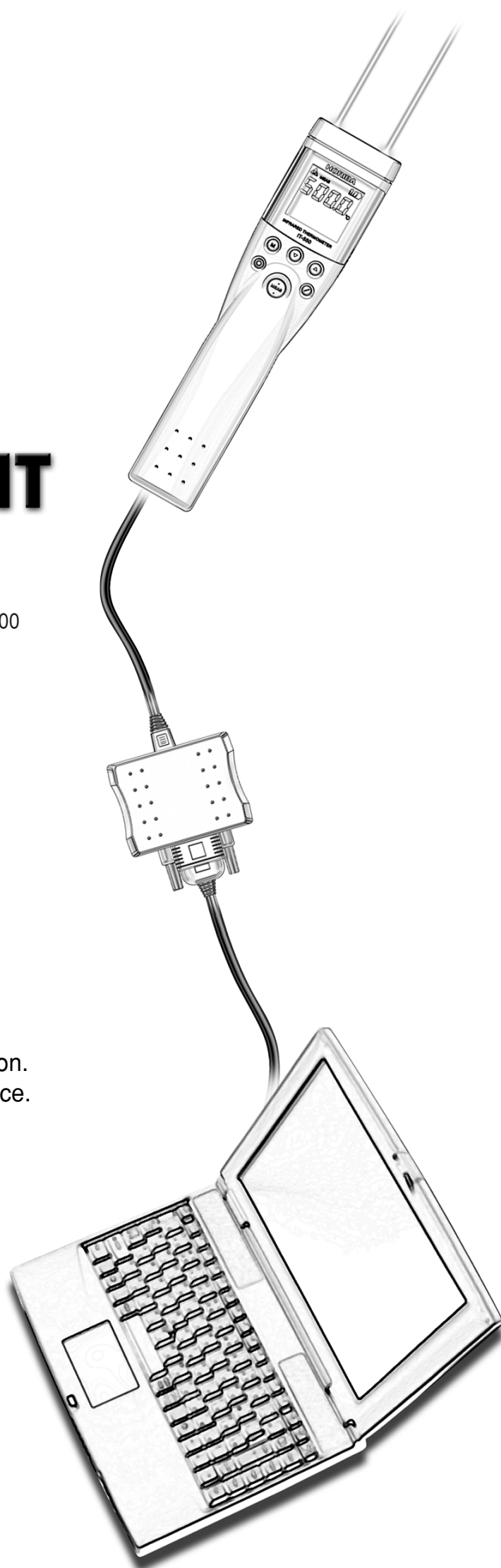

Introduction

Welcome to HORIBA's Expansion Kit for the IT-550 series infrared thermometer.

This instruction manual has been prepared for those who will handle the product. The person handling the product is assumed to

have a basic knowledge of the personal computer being used.

be able to operate the computer mouse.

be capable of basic operations, such as opening/closing windows.

be able to move to the target folder (directory) from the current folder (directory).

For a detailed explanation of these procedures, refer to the instruction manual, etc. that came with your personal computer.

For handling the IT-550, refer to the instruction manual that came with the IT-550.

For correct and safe operation of this expansion kit, carefully read this manual prior to use.

Caution

If the following cautions are not observed, the expansion kit may be damaged or may malfunction.

The expansion box is not dustproof or splash-resistant. Do not use the kit in a place where dust or water will get on it. Also, the IT-550 is not dustproof or splash-resistant when the modular cable is connected.

Do not bend or stretch the cable with extreme force.

When connecting/disconnecting the connector, be sure to hold the connector portion. Pulling the cable portion may damage the connector.

If Windows 95™ is operated continuously for more than one month, it may stop for several hours. Although Windows 95™ automatically recovers, the data cannot be collected while the system is down. Therefore, Windows NT™ is recommended for continuous data collection.

Limitation of responsibility

Please note the following limitation before using this product.

HORIBA, Ltd. will assume no responsibility for damage to data resulting from the breakdown of this product or the wrong operation of the product by you or a third party.

Contents

Chapter 1	Prior to use	2
Chapter 2	Configuration	3
Chapter 3	Use of Personal Computer (common to IT-550F/L/S)	4
3.1	Connecting to the personal computer	4
3.2	Installing the software on your personal computer	5
3.2.1	General specifications of TEMP Utility	5
3.2.2	Installation	6
3.3	Reading memory data (for IT-550F only)	8
3.3.1	Basic usage	8
3.3.2	Data processing	11
3.3.3	Saving or reading the file and printing	13
3.3.4	Main unit setup	14
3.4	Real-time measurement (for IT-550L/S)	15
3.4.1	Basic use 1 (Real-time measurement)	15
3.4.2	Basic use 2 (Monitor measurement)	20
3.4.3	Data processing	20
3.4.4	Saving or reading of the file and printing	22
3.4.5	Main unit setup	24
3.4.6	Graph display	26
Chapter 4	Using the printer (for IT-550F only)	31
4.1	Connecting the printer	31
4.2	Printing thermometer memory data	32
Chapter 5	Connecting the Recorder (for IT-550L/S)	33
5.1	Connecting the recorder	33
5.2	Setting analog voltage output scale	34
Chapter 6	Troubleshooting	36
Chapter 7	Reference Data	37
7.1	TEMP Utility specifications	37
7.2	Communication specifications	38

Chapter 1 Prior to use

Contents of the kit

Software for personal computer (TEMP Utility)
Floppy disks: 4 (2 disks for Japanese version and 2 disks for English version)
Expansion box (EX-5): 1
Modular cable: 1
Analog output cable: 1
Ferrite core: 2 Large 1 (for analog output cable)
 Small 1 (for modular cable)
Instruction manual (this manual) : 1

Attaching the ferrite core

It is recommended to attach a ferrite core to each cable to prevent any influence from electromagnetic waves.

Note

CE marking is obtained in the state where the ferrite core is attached to the cable.

Modular cable

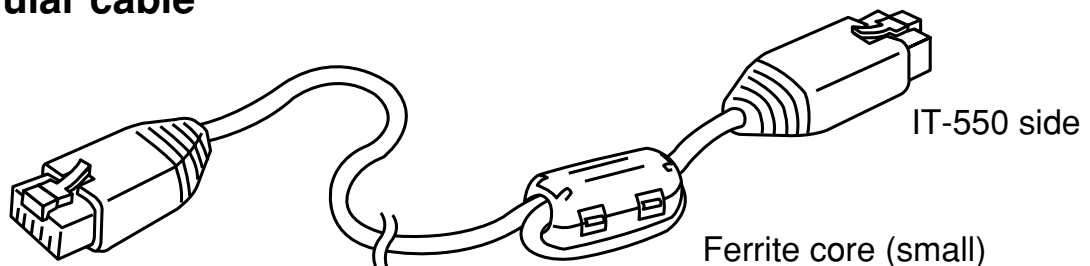

Wind the cable double, and attach the ferrite core as close to the IT-550 side connector as possible.

Analog cable, RS-232C cable and AC adaptor cable

Like the modular cable, wind the analog output cable, RS-232C cable or AC adaptor cable double around the ferrite core (large), and attach it as close to the expansion box side as possible.

When the analog output cable, RS-232C cable and AC adaptor cable are used, obtain a ferrite core ZCAT 3035-1330A (manufactured by TDK) separately from a personal computer store.

Chapter 2 Configuration

IT-550F (for field use)

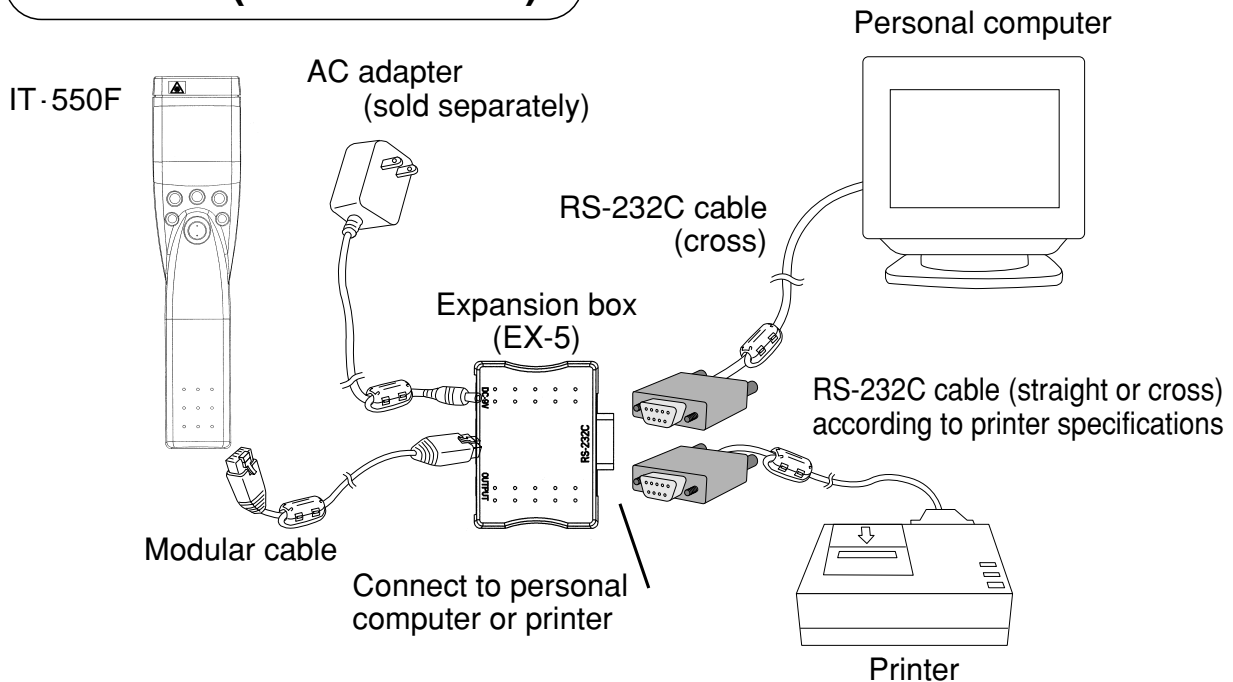

IT-550L/S (for laboratory use)

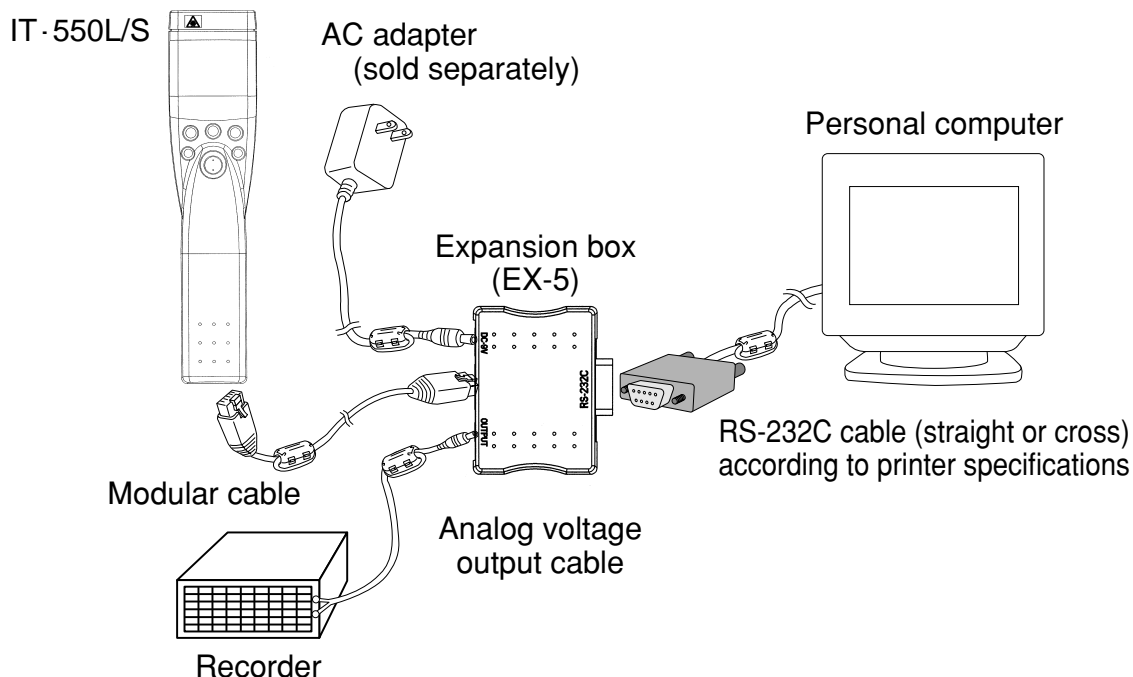

Caution

Purchase the RS-232C cable and the printer cable from a computer shop. Refer to 3.1 "Connecting the personal computer" and 4.1 "Connecting the printer."

Use of the wrong connection (cross connection vs. straight connection) with the RS-232C cable will damage to IT-550.

Carefully confirm all connections prior to connecting to the expansion box.

3.1 Connecting to the personal computer

Required items:

- IT-550F, IT-550L or IT-550S main unit
- Expansion kit (expansion box, modular cable, software floppy disks)
- RS-232C cable (cross connection)
- Personal computer

RS-232C cable selection

Connect the RS-232C cable to the connector indicated as RS-232C on the expansion box and to the COM port of the personal computer.

 The COM port of the personal computer is the connector for communication with external equipment, such as a modem. In most cases, the computer has two male connectors of nine protruding pins at the back or one connector (for notebook-type personal computers).

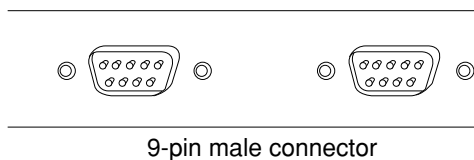

The RS-232C cable has two types of connectors: straight and cross. A cross connection RS-232C cable is used to connect the expansion box to the personal computer. (Refer to figure below.)

An RS-232C cable can be obtained at a personal computer store. Please purchase the type conforming to your computer.

9-pin connector at PC side:

A D-SUB 9P female cross cable is required for both.

Connecting cables

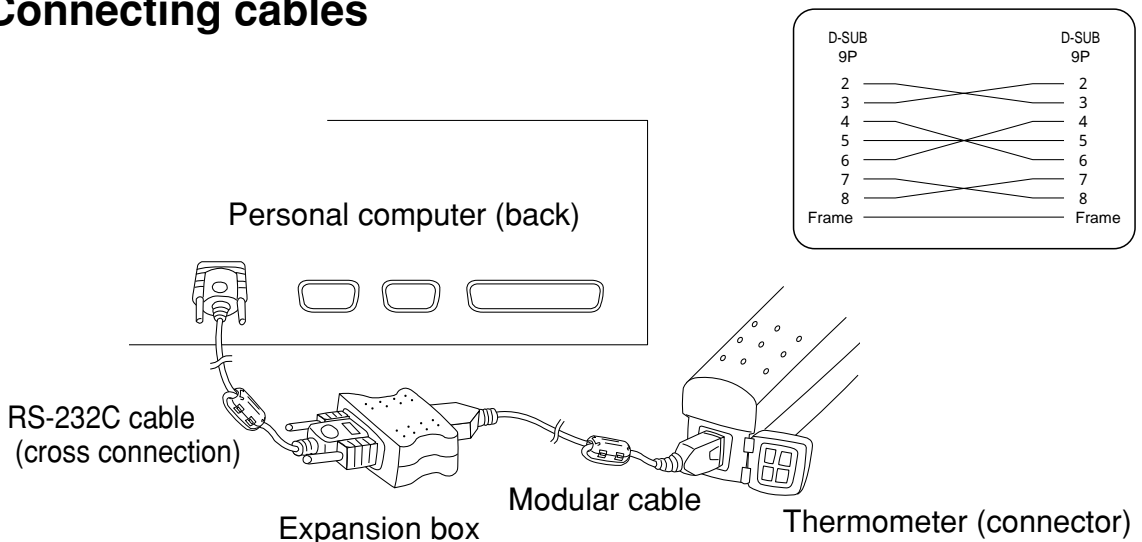

3.2 Installing the software on your personal computer

 **Caution:** Confirm or understand the following before starting installation:

"TEMP Utility" is a product of HIOKI E.E. CORPORATION

The reproduction, copying, or alteration of part or all of the "TEMP Utility" for any purpose other than controlling the infrared thermometer or processing the data is prohibited by law.

The "TEMP Utility" may be changed or upgraded by HIOKI E.E. CORPORATION without notice.

When the "TEMP Utility" is to be quoted in a published work, prior permission from HIOKI E.E. CORPORATION is required. Further, use of the trademark "HIOKI" is not permitted.

HIOKI E.E. CORPORATION or HORIBA, Ltd. will assume no responsibility for the resulting operation of the "TEMP Utility" by the user.

Internet Explorer Ver. 4.00 or more is required.

Floppy disks

Do not drop, bend or mishandle the floppy disks.

Do not put the floppy disks in a place where they will be exposed to direct sunlight, near a strong magnetic field, or close to a heating device.

Do not get the floppy disks wet.

3.2.1 General specifications of TEMP Utility

Media: Four 3.5-inch 2HD (1.44 MB) floppy disks (two disks for Japanese version, two disks for English version)

(1) Operating environment

Main unit: Personal computer with CPU of i486DX4 or more that operates with Windows95™, Windows98™, or WindowsNT™4.0

Internet Explorer Ver. 4.00 or more

Memory: 16MB or more

Display: Resolution 800x600 dots, 16 colors or more

Hard disk: At least 4MB free space

(2) Recommended operating environment

Main unit: Personal computer with a Pentium 120MHz CPU or greater that operates with Windows95™, Windows98™, or WindowsNT™4.0

Internet Explorer Ver. 4.00 or more

Memory: 32MB or more

Display: Resolution 800x600 dots, 16 colors or more

Hard disk: At least 4MB free space

Registered trademark

Windows is the trademark of Microsoft Corporation, USA
i486DX4 and Pentium are trademarks of Intel Corporation, USA
Other product names are the trademarks or registered trademarks of following companies:

Copyright©1987-1997 Microsoft Corporation, all rights reserved.
Copyright©1998 HIOKI E.E. CORPORATION

Note

On this instrument, communication is checked using the following personal computers.

If any troubles should occur during communication, please contact us.
VM516S(EPSON), Vectra VL2 4/33S(HP), Optiplex GXPRO(Dell)
Satellite 315CDT(TOSHIBA), CliePro XVI(Micron), Lavie NX(NEC)

As regards the latest information on version up etc., refer to the URL.
<http://www.horiba.co.jp>

3.2.2 Installation

⚠ Caution

All programs should be closed.
If a power failure occurs or power to the computer is turned OFF during execution of Setup.exe, data stored on the hard disk may be damaged.

1 Insert Disk 1 of TEMP Utility (English) into the floppy disk drive.

2 Double-click My Computer on the desk top, and then double-click the icon 3¹/₂ Floppy (A:).

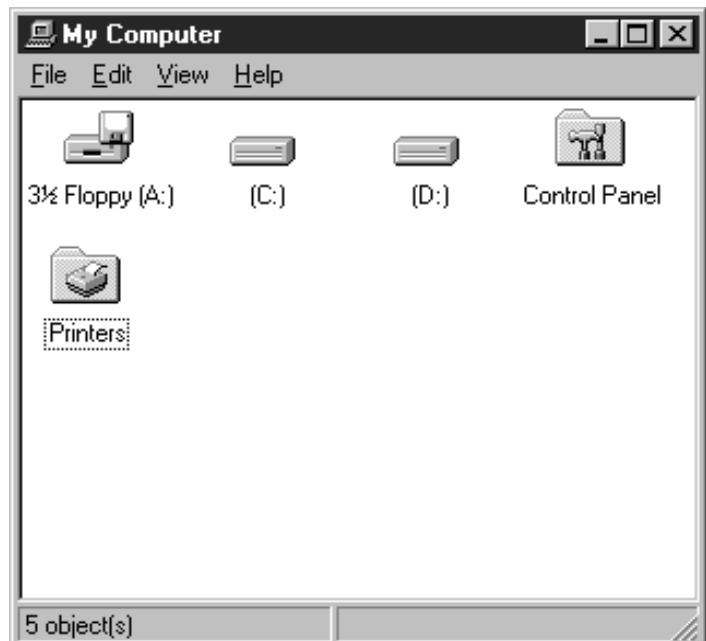

- 3 Double-click Setup.exe on the disk. The following dialog box appears.

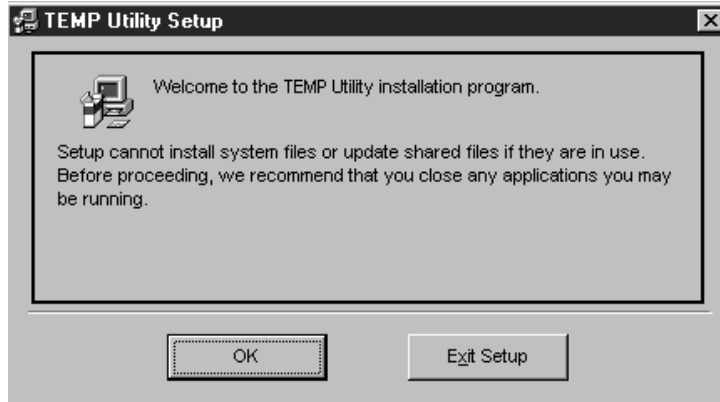

- 4 Install TEMP Utility in accordance with the instruction on the screen.
In some cases, you may be requested to restart Windows during installation.
Remove the floppy disk, and restart in accordance with the instructions on the screen.
When Windows™ restarts, perform installation from the beginning.

- 5 Confirm that installation has been completed correctly.
(The TEMP Utility icon is created in the sub-menu Programs of the Windows™ Start menu.)

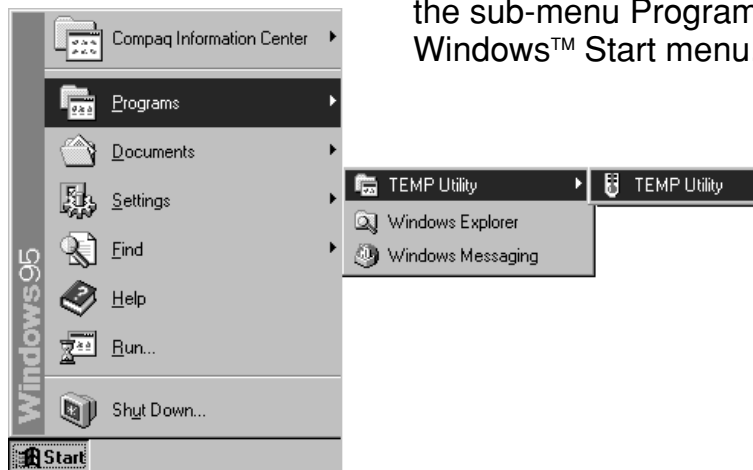

3.3 Reading memory data (for IT-550F only)

Make sure that the button on the infrared thermometer main unit shown at right diagram is **P**.

If this button is a , refer to the explanation for the laboratory use thermometer (see p. 15).

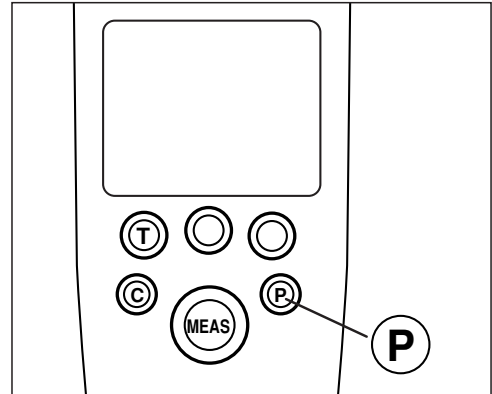

Memory data reading involves the following functions:

Reading memory data

Reads the memory data

measured with the IT-550F to the personal computer.

Displaying the memory data list (see p. 11)

Displays the measurement start and end time, the memory data number, the maximum value, minimum value, and average value for each data No. of memory data.

Data table (see p. 12)

Displays the measured data for each data No., and Hi/Lo can be judged by inputting the upper and lower limit.

3.3.1 Basic usage

Reading memory data

Reading the memory data measured with the IT-550F to the personal computer.

1

Start up the Read Memory Data

The TEMP Utility icon is created in the sub-menu Programs of the Windows™ Start menu.

The TEMP Utility [Start Up Menu] screen is displayed.

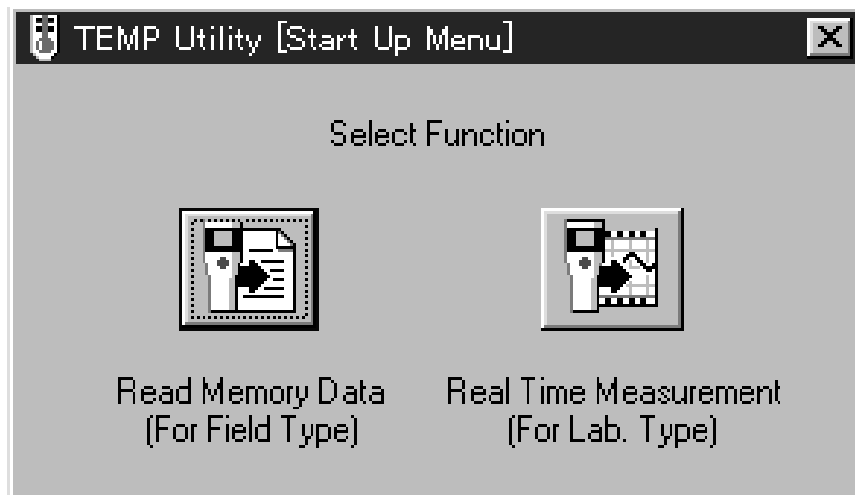

Select the Read Memory Data button.
Reading of the memory data starts.

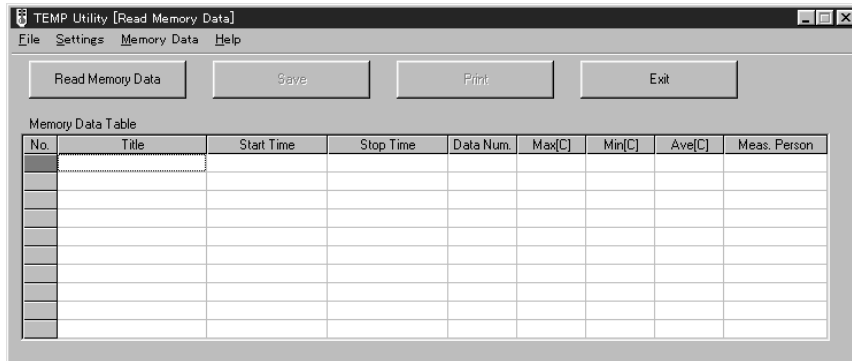

2 Set communication

Select COM port to enable communication.
Select the COM Port menu in the Settings menu from the menu bar.
Select COM port connected to the infrared thermometer from COM1 to COM4.
If you do not know which COM port the infrared thermometer is connected to, select COM1 or COM2 under normal operation.

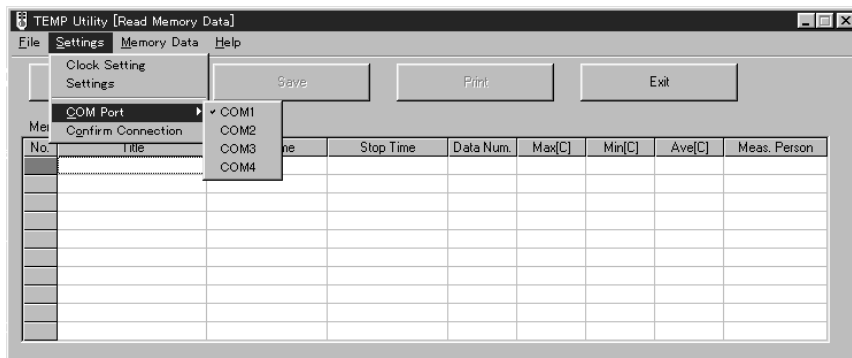

3 Check communication

When the infrared thermometer is connected to the personal computer and communication setup has been completed, confirm communicability. Select the Confirm Connection in the Settings menu from the menu bar. Operation in accordance with the instructions allows you to check the communicability.

If the connection is incorrect, change the COM port and check again.

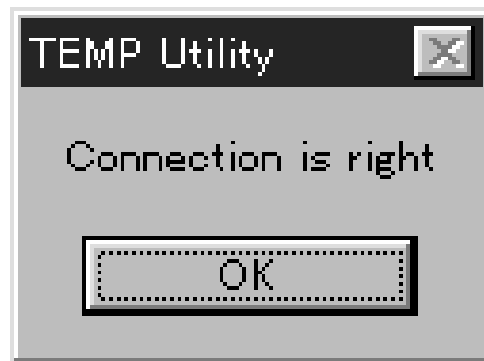

4 Read thermometer memory data to the personal computer

Select the Read Memory Data button to confirm that the memory data of the IT-550F has been transmitted to the memory data list.

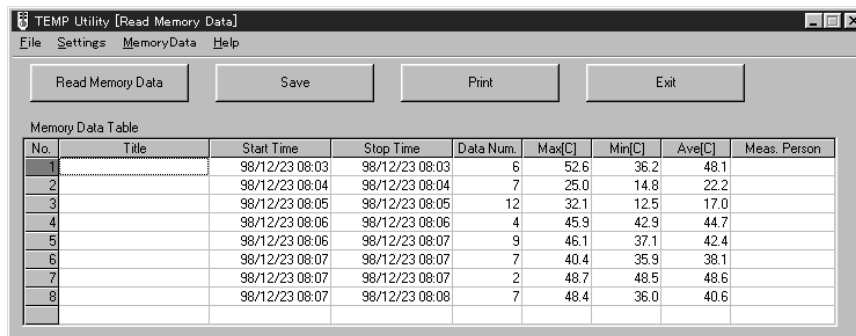

The image shows a window titled "TEMP Utility [Read Memory Data]" with a menu bar (File, Settings, MemoryData, Help) and buttons for "Read Memory Data", "Save", "Print", and "Exit". Below the buttons is a table titled "Memory Data Table".

No.	Title	Start Time	Stop Time	Data Num.	Max[C]	Min[C]	Ave[C]	Meas. Person
1		98/12/23 08:03	98/12/23 08:03	6	52.6	36.2	48.1	
2		98/12/23 08:04	98/12/23 08:04	7	25.0	14.8	22.2	
3		98/12/23 08:05	98/12/23 08:05	12	32.1	12.5	17.0	
4		98/12/23 08:06	98/12/23 08:06	4	45.9	42.9	44.7	
5		98/12/23 08:06	98/12/23 08:07	9	46.1	37.1	42.4	
6		98/12/23 08:07	98/12/23 08:07	7	40.4	35.9	38.1	
7		98/12/23 08:07	98/12/23 08:07	2	48.7	48.5	48.6	
8		98/12/23 08:07	98/12/23 08:08	7	48.4	36.0	40.6	

Note:

If there is a large discrepancy between the date set in the IT-550F main unit and the date set in the personal computer (more than one month), dates on the personal computer may not be displayed correctly.



Clearing the memory data of thermometer

The memory data of thermometer can be completely cleared using the personal computer. Select the Clear Memory Data menu in the Memory Data menu from the menu bar.

5 Ending

Select the Exit button.
TEMP Utility is closed.

3.3.2 Data processing

Making good use of the data with your personal computer

Memory Data Table

Memory data for the IT-550F is managed according to blocks named for data No. A maximum of 130 readings can be stored in the memory for any data No., and the available data Nos. are 1 to 64.

However, the total number of data readings that can be stored for all the data Nos. combined is 130.

In the Memory Data Table, the title, start time and stop time, the number of memory data, maximum value, minimum value, average value, and the person taking the measurements are displayed for each memory data No.

No.	Title	Start Time	Stop Time	Data Num.	Max[C]	Min[C]	Ave[C]	Meas. Person
1	data01	98/12/23 08:03	98/12/23 08:03	6	52.6	36.2	48.1	ohsuga
2	data02	98/12/23 08:04	98/12/23 08:04	7	25.0	14.8	22.2	matsumoto
3	data03	98/12/23 08:05	98/12/23 08:05	12	32.1	12.5	17.0	nomura
4	data04	98/12/23 08:06	98/12/23 08:06	4	45.9	42.9	44.7	tsujioka
5	data05	98/12/23 08:06	98/12/23 08:07	9	46.1	37.1	42.4	matsuyama
6	data06	98/12/23 08:07	98/12/23 08:07	7	40.4	35.9	38.1	hayakawa
7	data07	98/12/23 08:07	98/12/23 08:07	2	48.7	48.5	48.6	kanai
8	data08	98/12/23 08:07	98/12/23 08:08	7	48.4	36.0	40.6	yamamoto

Note

When the measured value is beyond (or under) the display temperature range, the upper limit 505 (or the lower limit - 55) is input as the data.

Enter the title and the person taking measurements in the measurement data.

The title and the person taking the measurements can be entered in the Memory Data Table.

The reliability of the measured data increases when the title and the person measuring in responsible for the measured data entered. It is recommended to enter these items without fail.

Double-click on the Title cell of each data No. or the Meas. Person cell in the Memory Data Table. Enter the text, and hit the Return key.

Data Table

The measured data for each data No. can be viewed by displaying the Data Table.

When the Data Table menu in the Memory Data menu is selected, the Data Table display can be switched ON/OFF.

Selection of the data No. displayed

Click on the cell of the data No. to be displayed in the Memory Data Table.

When the number is selected, the color of the number portion at the far left of the table changes.

The measured data of the selected data No. is shown in the Data Table.

Clicking on the button in the Data Table displays the Data Table of the previous data No. and clicking on the button displays the Data Table of the next data No.

Min. value (blue)

Max. value (red)

No.	Date	Time	Data[C]	Judg.
1	98/12/23	08:03	36.2	
2	98/12/23	08:03	52.3	
3	98/12/23	08:03	49.3	
4	98/12/23	08:03	52.6	
5	98/12/23	08:03	51.8	
6	98/12/23	08:03	46.2	

Judgment function

The Data Table has a place to enter the upper limit value and lower limit value. By entering numerical values in this cell, the measured data can be judged. Judgment results are displayed in the Judg. column of the Data Table.

Hi : Displayed when the measured value is above the upper limit value.

Lo : Displayed when the measured value is below the lower limit value.

When the measured value is within the range, nothing is displayed.

If "-" is entered in the input section of the upper limit value or lower limit value, the respective judgment function is ignored. If "-" is entered in both input cells, the judgment function is turned OFF.

Judgment value

No.	Date	Time	Data[C]	Judg.
1	98/12/23	08:03	36.2	Lo
2	98/12/23	08:03	52.3	Hi
3	98/12/23	08:03	49.3	
4	98/12/23	08:03	52.6	Hi
5	98/12/23	08:03	51.8	Hi
6	98/12/23	08:03	46.2	

3.3.3 Saving or reading the file and printing

Saving the measured data in a file

The measured data of all data Nos. are collectively saved in one file. Select the Save As menu in the File menu from the menu bar. Enter the file name or select the file, and select the Save button. The data is saved.

To update the file after having changed the title or the measuring person with the data read from the file, select the Save menu in the File menu from the menu bar. The file is saved in CSV format (text file punctuated with commas).

Saving of data with many numbers may take a long time.

Reading the measured data from the file

Select the Open menu in the File menu from the menu bar. Select the file name, and select the Open button to start reading.

Printing

The measured data of all data No. is collectively printed.

Select the Page setup menu in the File menu from the menu bar. Set selection of printer and paper size.

Select the Print menu in the File menu from the menu bar. The printing dialog box is displayed. Make the necessary settings, and print.

Selecting the Print button also starts printing.

Note

It is not possible to print the data of the Table only or of each data No. individually.

3.3.4 Main unit setup

Date, time, and emissivity of the IT-550F main unit can be set from TEMP Utility.

Setting the main unit clock

Select the Clock Setting menu in the Settings menu .

Set the time, and select the OK button. The data is transmitted to the main unit, and the time is set.

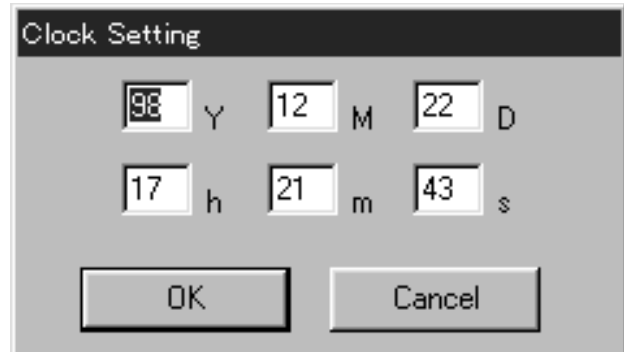

Main unit setup

Measurement setting for transmitting to the infrared thermometer
Select the Settings menu in the Setting menu.

The main unit Settings screen appears.

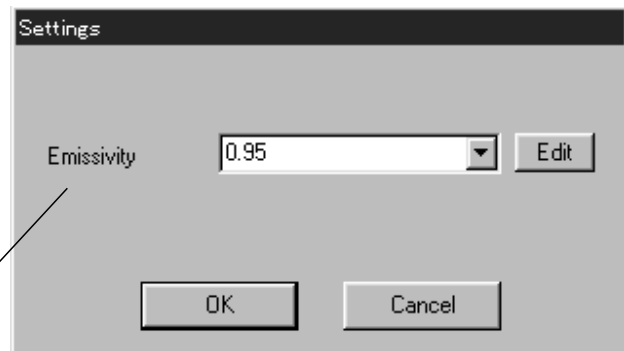

Emissivity setting

To set the emissivity, enter the numerical value directly or select from the list.

Setting range is 0.10 to 1.00 with a resolution of 0.01.

Selecting the Edit button allows you to edit the contents.

Editing the Emissivity lists

A total of ten emissivity lists can be registered.

Adding:

Click on the portion to be added in the list.

Type in the content to be added in the input cell for material and/or emissivity, and select the Add button.

Deleting

Click on the item to be deleted from the list.

When the Delete button is selected, the item is deleted.



Changing

Click on the item to be changed in the list.

Type in the content to be added in the input cell for material and/or emissivity, and select the Edit button.



3.4 Real-time measurement (for IT-550L /S)

Make sure that the button of the infrared thermometer main unit shown at right diagram is . In case of , refer to Field use (page 8).

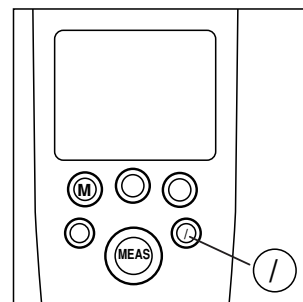

Real-time measurement has the following functions:

Real-time measurement

Connected to the infrared thermometer through RS-232C, it reads the measured data to the personal computer in real time and stores the data in the memory.

Displaying 8-channel data table (see p. 20)

It is possible to display a maximum of 8 channels of the real-time measured value data and the measured data read from the file as data tables.

Graph display (see p. 26)

It is possible to display the read data for a maximum of 8 channels.

Scale for time axis and temperature axis, and optional zooming are possible.

Reading of the value by cursor and statistic calculation for cursors are possible.

Note

Do not touch the buttons on the infrared thermometer main unit during the real-time measurement. the operation may cause any data is read as 0.0. Stop the real-time measurement before changing the main unit settings.

Do not operate the mouse on TEMP Utility and Excel during the real-time measurement. The operation may cause data omission.

3.4.1 Basic use 1 (Real-time measurement)

Real-time measurement

It is possible to connect the infrared thermometer to the personal computer using an RS-232C cable, read the measured data at real time, and store it in your personal computer.

1

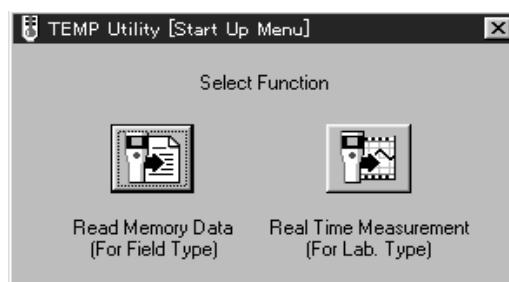

Select the Real Time Measurement button.

Real-time measurement starts.

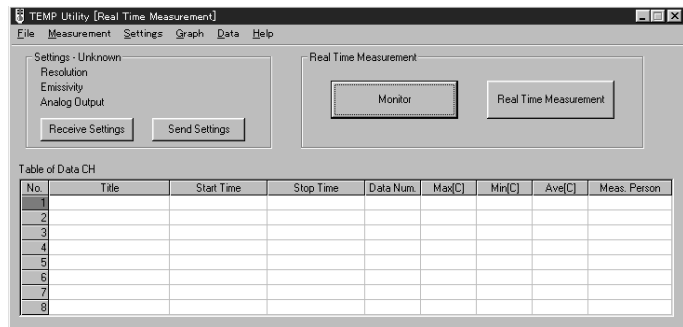

2 Set the communication

Select COM port to enable communication.

Select the COM Port menu in the Settings menu from the menu bar. Select the COM port connected to the infrared thermometer from COM1 to COM4.

If you do not know which COM port the infrared thermometer is connected to, select COM1 or COM2 under normal operation.

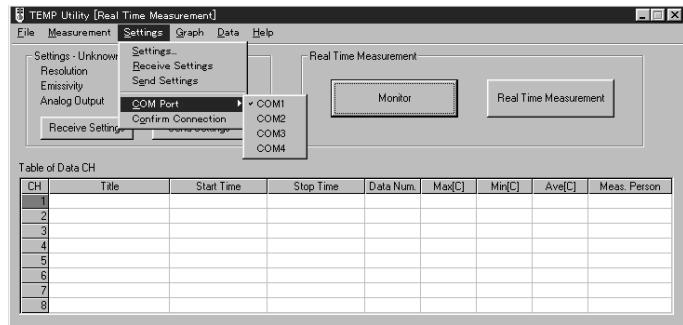

3 Check the communication

When the infrared thermometer is connected to the personal computer and communication setup has been completed, confirm communicability.

Select the Confirm Connection menu in the Settings menu from the menu bar. Operation in accordance with the instructions allows you to check the communicability.

If the connection is incorrect, change the COM port and check again.

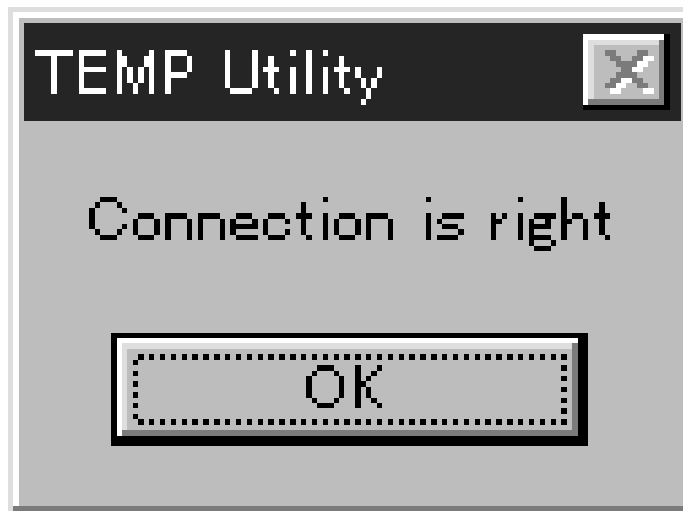

4 Read the measured data of the thermometer into the personal computer

Select the memory storage CH

Press the Real Time Measurement button or select the Real Time Measurement menu in the Measurement menu. The Real Time Measurement Select CH screen is displayed.

Select the CH No. to which the measured data is read, and select the OK button.

The color of the selected CH number at the far left of the list changes.

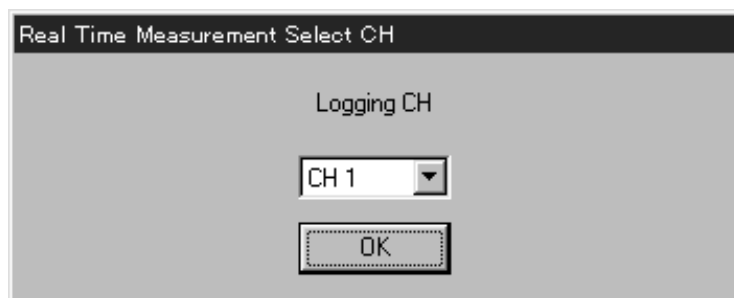

Set the conditions for real-time measurement.

When the Measurement Time Setting screen is displayed, set up as follows:

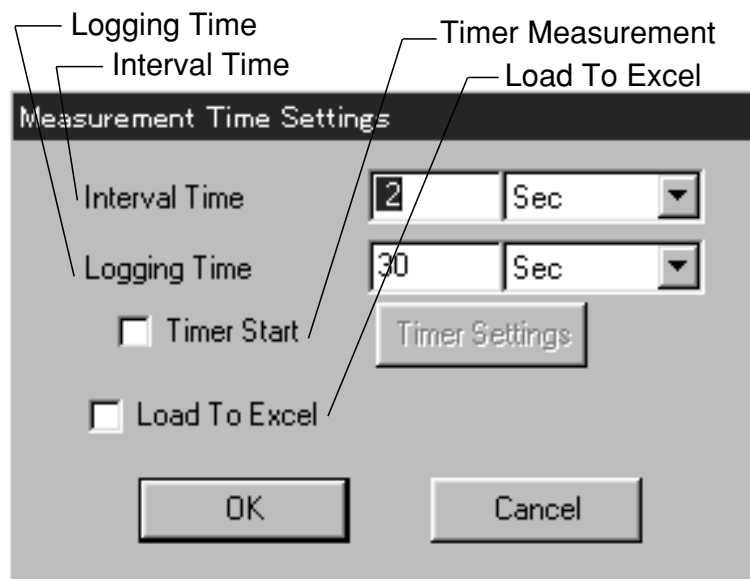

(1) Interval setting

Decide the interval (measurement interval) by selecting the figure and unit.

(2) Logging time setting

Similarly, decide the logging time (measurement time) by selecting the figure and unit. When "Continuous" is selected, measurement continues until it is stopped manually. When "Continuous" is selected, the figures cannot be input.

Further, if "Times" is selected, measurement is performed only for the count that was set. Measurement count includes the

measurement start time as one time. The measurement time interval is the time set in Interval Time.

(3) Timer measurement

When performing timer measurement, check the "Timer Start" check box in the Measurement Time Settings dialog box. When the check box is checked, the Timer Settings screen appears automatically. To change or confirm the timer time later, select the "Timer Settings" button next to the "Timer Start" check box. The Timer Settings screen is displayed.

Timer setting

Measurement start time and stop time or measurement time can be set with the Timer Settings screen. For the measurement stop time, specify the end time directly or set with the measurement time. If "Continuous" is selected for the measurement time, measurement can be stopped manually when it was started with the timer.

The image shows a 'Timer Settings' dialog box. It has a title bar with a close button. The dialog is divided into three main sections. The first section is 'Start Time', which contains a date and time picker with fields for Year (98), Month (12), Day (22), Hour (17), Minute (33), and Second (00). The second section is 'Stop Time', which has two radio buttons: 'Specify End Time' (which is selected) and 'Specify Interval'. Below these radio buttons is a date and time picker identical to the 'Start Time' section. The third section is 'Specify Interval', which has a text box containing the number '1' and a dropdown menu currently set to 'Continuous'. At the bottom of the dialog are two buttons: 'OK' and 'Cancel'.

(4) Option of reading to Excel

This option is valid if Microsoft Excel software has been installed.

When the "Load to Excel" check box is checked, the measured value can be read to an Excel table in addition to normal real-time measurement.

Note

Excel 97 or later should be used to load 16383 or more data with this option.

Starting the Real Time Measurement

After setting the interval and logging time, select the OK button in the Measurement Time Settings screen, and proceed in accordance with the instructions to start measurement.

The screen displays the Real Time Measurement window for the measured values and the data table to which the measured values are stored.

When the option of reading to Excel is specified, Excel starts automatically and the data is read to a new BOOK sheet.

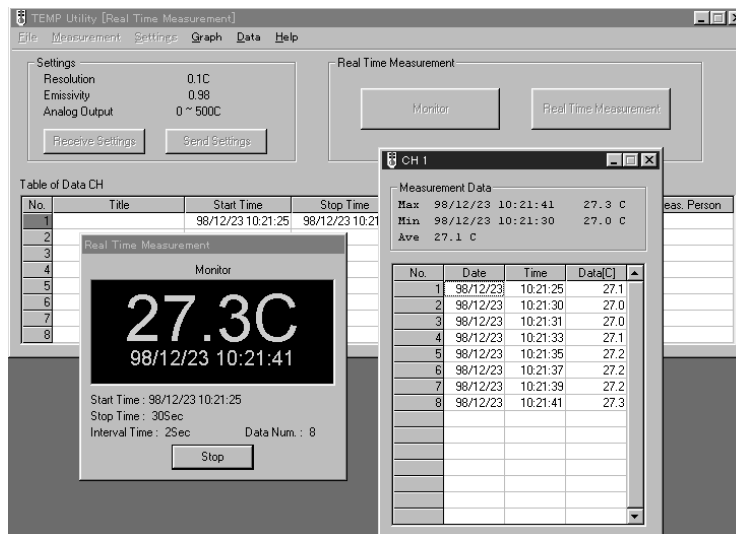

Stopping the Real Time Measurement

Selecting the Stop button stops the real-time measurement. Measurement results up to this time are displayed in the measurement data CH list and the data table.

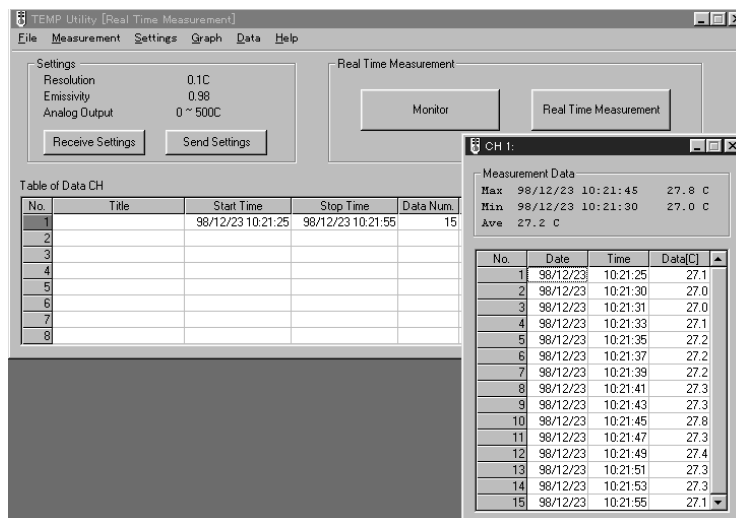

3.4.2 Basic use 2 (Monitor measurement)

Monitor measurement

With Monitor measurement, the measured data is read in real time from the infrared thermometer at an interval of one second, and displayed on the screen. As the measured data is not stored, this measurement can be performed easily if operation check or recording is not required. To start Monitor measurement, select the Monitor Measurement button or select the Monitor menu in the Measurement menu from the menu bar.

3.4.3 Data processing

Making use of the data with your personal computer

The real-time measurement measured value data or data read from the file are displayed in the Table of Data CH. It can be displayed also as each data table up to a maximum of 8 channels. Also, the maximum value, minimum value, and average value of the data are calculated and displayed.

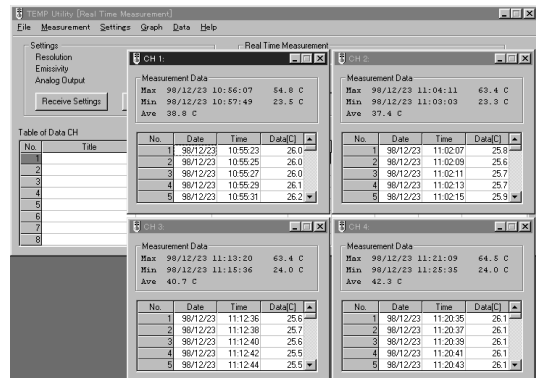

Note
When the measured value is beyond (or under) the display temperature range, the upper limit 505 (or the lower limit - 55) is input as the data.

Table of Data CH

Enter the title and person taking measurements in the measurement data.

The title and the person taking measurements can be entered in the Table of Data CH. The reliability of the measured data increases when the title and the measuring person as the responsible person for the measured data are entered. It is recommended to enter these items without fail. Double-click on the Title cell of each data No. or the Meas. Person cell in the Table of Data CH. Enter the text, and hit the Return key. Entry is not possible in a CH that has no measured data.

Chapter 3

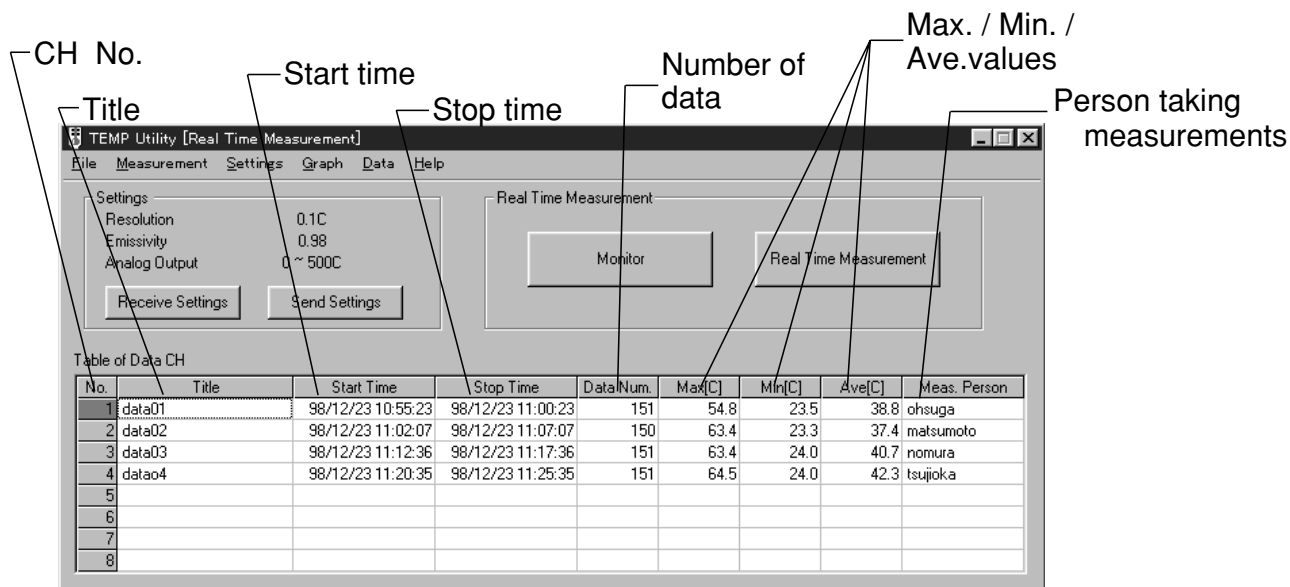

Data table

The measured data of each CH by real-time measurement can be viewed when the data table is displayed.

Selecting the CH1 menu in the Data table menu allows you to switch the data display ON/OFF. A maximum of 8 channels can be displayed at one time.

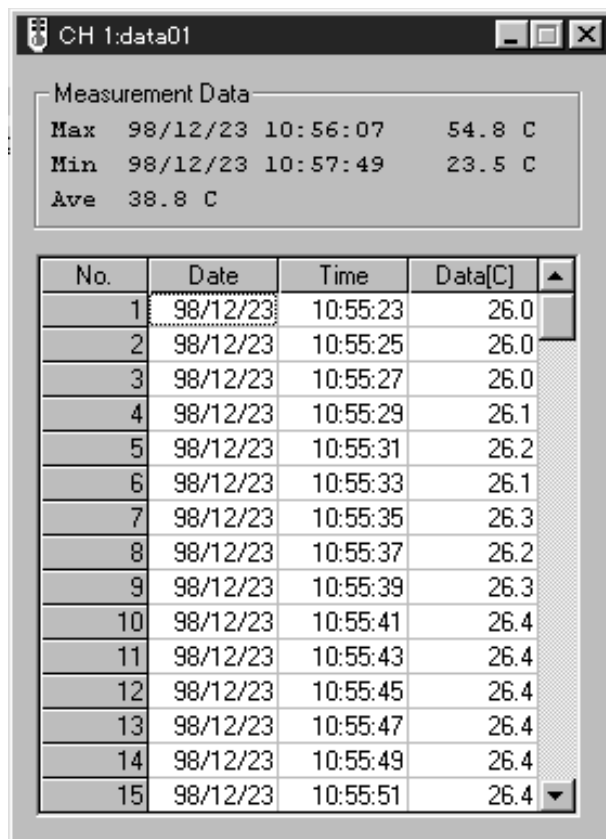

3.4.4 Saving or reading of the file and printing

Saving the measured data in the file

Select the CH to be saved.

Select the Save As menu in the File menu from the menu bar. Select the CH to be saved in the File Save Select CH screen, and select the OK button.

Note: If you try to select a CH that contains no data, an error message is displayed.



Store the measured data.

Enter the file name in the Save As screen or select the file and select the Save button. The data is saved.

To update the file after having changed the title or the measuring person with the data read from the file, select the Save menu in the File menu from the menu bar. The file is saved in CSV format (text file punctuated with commas).

Saving of data with many numbers may take a long time.

Reading from the file of the measured data

Select the CH to be read.

Select the Open menu in the File menu from the menu bar.

Select CH to be read on File Open Select CH screen, and select the OK button.



Reading the measured data

Enter the file name in the Open File screen or select the file and select the **Open** button. The data is read.

If the number of data is large, it may take a long time to load.

Printing

Select CH to be printed.

The measured data of each CH is printed.

Select the Page Setup menu in the File menu. Set selection of printer and paper size.

Select the Print menu in the File menu. Select CH to be printed in the Print Out Select CH screen, and select the **OK** button.

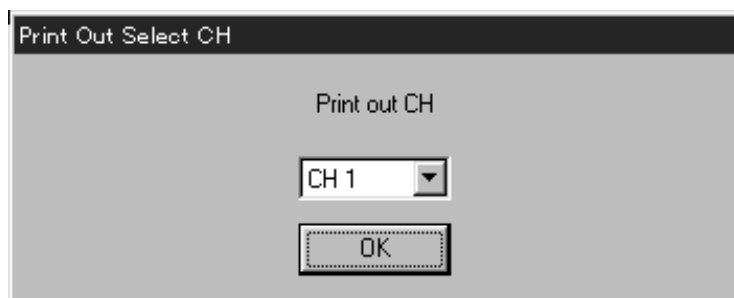

Print the measured data.

When the print screen is displayed, make the required setting and start printing.

Note:

It is not possible to print the data of all CH at one time.

3.4.5 Main unit setup

Resolution, emissivity, and scaling of the analog voltage output of the IT-550L/S is main unit can be set from the TEMP Utility.

Main unit setup

Each set value to be transmitted to the infrared thermometer is set. Select the Settings menu in the Setting menu from the menu bar. Settings screen appears.

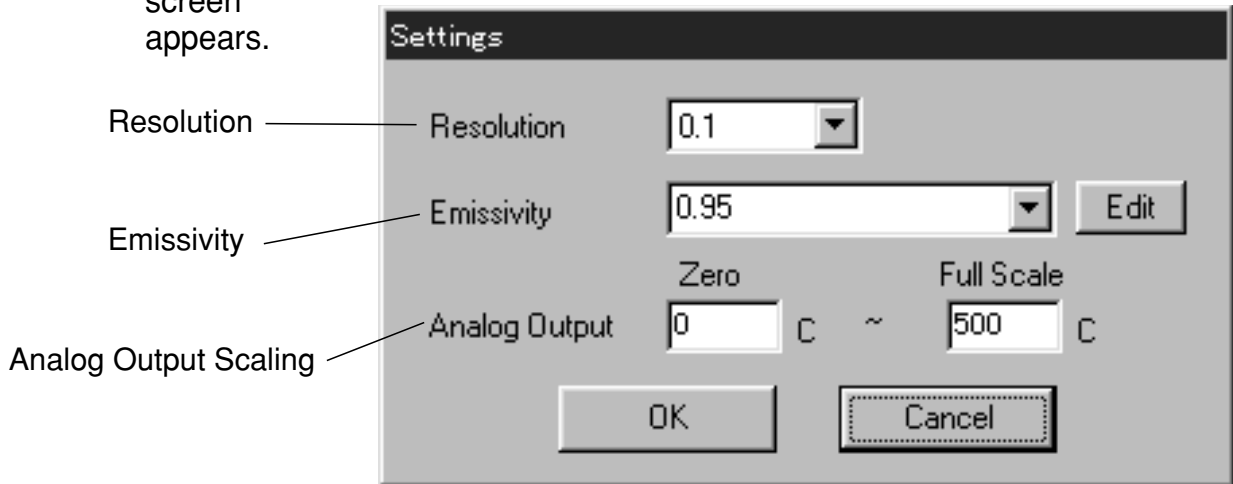

(1) Resolution

Select 0.1 or 1 for measurement resolution.

(2) Emissivity

To set the emissivity, enter the numerical value directly or select from the list.

Setting range is 0.10 to 1.00 with a resolution of 0.01.

Selecting the Edit button allows you to edit the content of the list.

Editing the Emissivity list

A total of ten emissivity lists can be registered.



Adding:

Click on the portion to be added in the list.

Type in the content to be added in the input cell for material and/or emissivity, and select the **Add** button.

Deleting

Click on the item to be deleted from the list.

When the **Delete** button is selected, the item is deleted.

Changing

Click on the item to be changed in the list.

Type in the content to be added in the input cell for material and/or emissivity, and select the **Edit** button.

(3) Analog output scaling

Set the temperature corresponding to zero output and full-scale output of analog output.

Setting range is -50 to 500 with 1 resolution.

However, the difference between the zero and full-scale values should be set 10 or more.

Main unit setup transmission

Selecting the **Send Settings** button transmits the set values to the main unit.

Main unit setting reception

Selecting the **Receive Settings** button allows you to read the main unit present various set values.

3.4.6 Graph display

The data read from a maximum of 8 channels can be displayed in a graph simultaneously. It is possible to change the scale of the time axis and the temperature axis, and free zooming. It is also possible to perform readout of the values and statistical calculation between cursors.

Select the Graph menu in the Graph menu from the menu bar to display the TEMP Utility [Graph] screen.

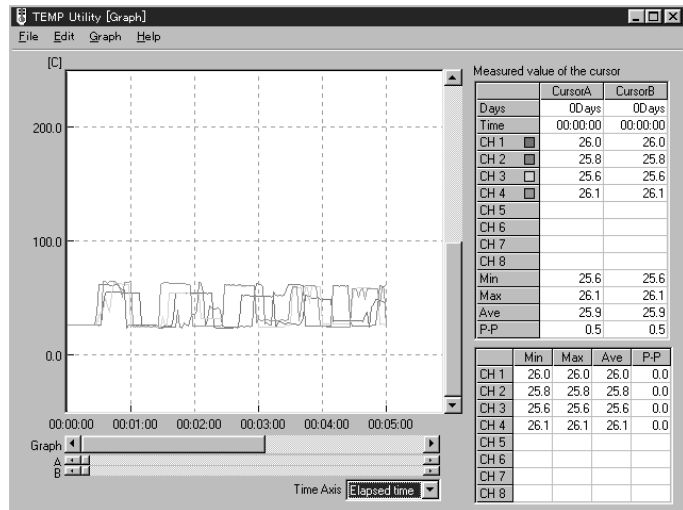

Before starting real-time measurement or during real-time measurement, select the Graph menu in the Graph menu from the menu bar, and execute real-time measurement. Measurement can be performed while plotting the present value on the graph. But, as operation may become unstable, do not overlap other screens on the graph.

Setting the time axis

Select the Time axis setting menu in the Graph menu from the menu bar. When [Auto Ranging] is selected, the time axis is automatically set so that all measured data are contained in the display screen.

By selecting the Display A-B Range, the sub-menu portion between cursors A and B is magnified and displayed. When the time of [1Sec], [5Sec] ... is selected, one scale on the graph is used as the selected time.

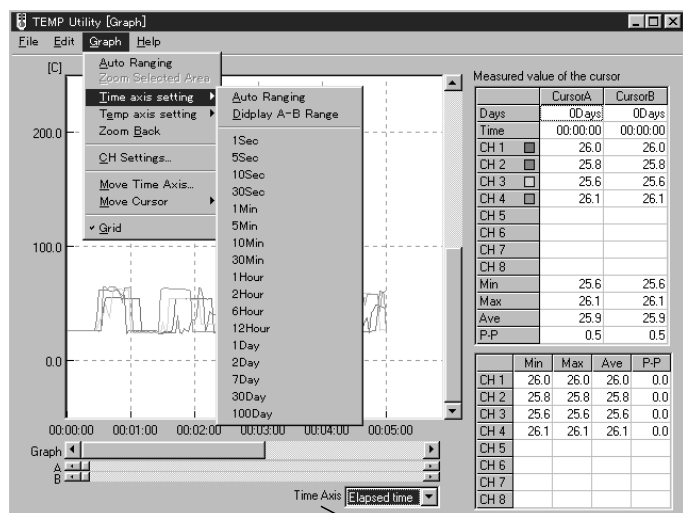

Time axis

Chapter 3

When the Time axis is set to [Elapsed time], the time axis displayed shows the time passed from measurement start.
To show the measurement time of each channel, select the CH No.

Temperature axis setting

Select the Temp axis setting menu in the Graph menu from the menu bar.
When Auto Ranging is selected, the temperature time axis is automatically set so that all measured data are contained in the display screen in the time axis range displayed on the screen.

By selecting the Temp Display Range..., the display range of time axis can be set.

When a temperature like [0.1], [0.5] ... is selected, one scale on the graph is used as the selected temperature.

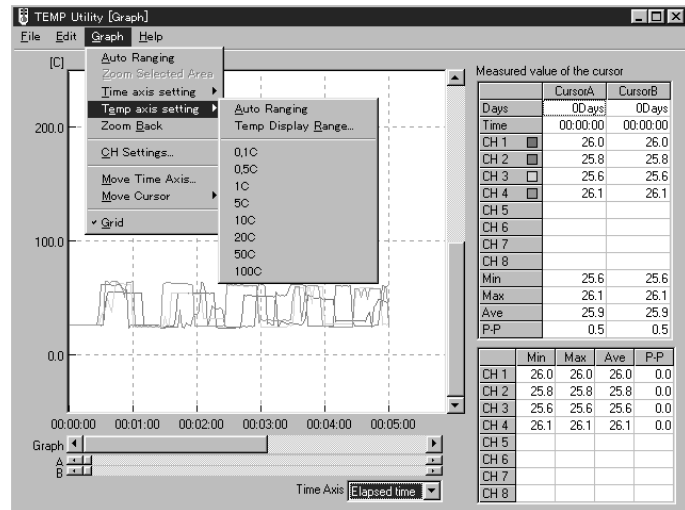

Zoom

Press the right button of the mouse while in the graph screen to select the zooming rate from [Zoom Time] and [Zoom Temp].

By selecting [Mem Scale], the zooming rate of the time axis and temperature and graph display position can be memorized by No. (max. of 5)

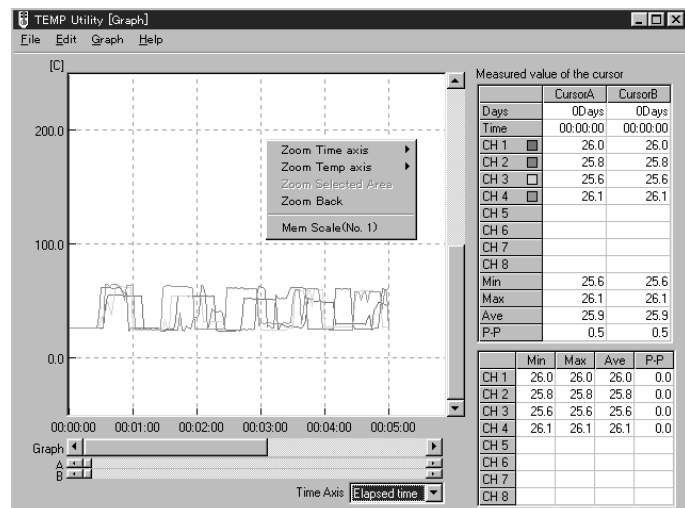

Arbitrary zooming range

While pressing the left mouse button, drag the portion to be zoomed on the graph screen and select the range.

When selected, press the right button of the mouse at that spot and select the Zoom Selected Area menu. To return to the previous state, press the right button of the mouse on the graph screen to select the Zoom Back menu.

Selecting the Zoom Selected Area menu in the Graph menu or the Zoom Back menu in the Graph menu performs the same operation.

Setting Waveform display position

For long-term data collection, the cursor position from the present display position in the specified time can be displayed quickly.

Set the display position of the waveform in time axis direction.

Selecting the Move Time Axis menu in the Graph menu from the menu bar displays the setup screen.

You can choose to set the time directly or by cursor (A or B) position.



Cursor

Two cursors (A and B) are used: the red cursor is cursor A and the blue one is B. The cursors can be moved only in the block that contains the data.

Information for the cursor is displayed in two tables on the right side of the screen.

The upper table displays the cursor time, reading value of each channel's measured value and statistical calculation values between channels.

The lower table displays the statistical calculation values for each channel between cursors A and B.

Chapter 3

The cursor also has the functions listed below.

- Zooming the time axis of the graph between cursors A and B
- Moving the waveform display position to the cursor position

Moving the cursor

To move the cursor, the following three ways are used:

- Operate the cursor scroll bar.
- Directly drag the cursor on the graph screen.
- Select the Move Cursor menu in the Graph menu from the menu bar to move the cursor to the specified time.

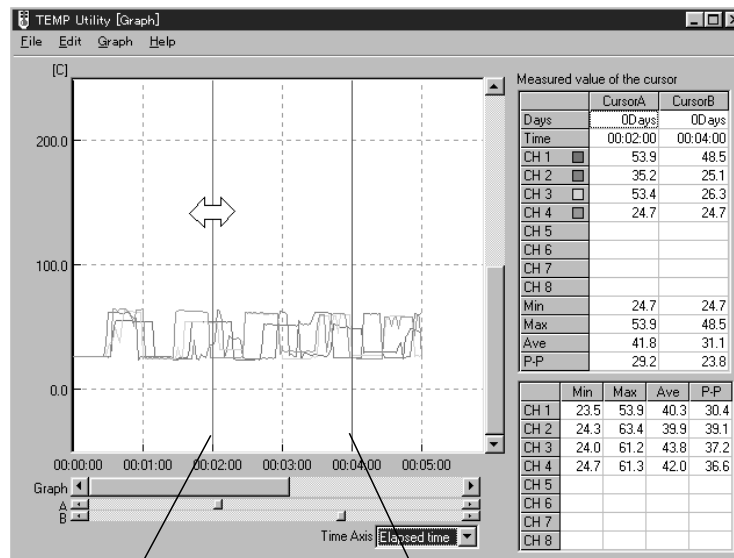

Cursor A (red)

Cursor B (blue)

CH settings

ON/OFF or the color of lines on the graph display of each channel can be specified.

Selecting the CH Settings menu in the Graph menu displays the CH Settings screen.

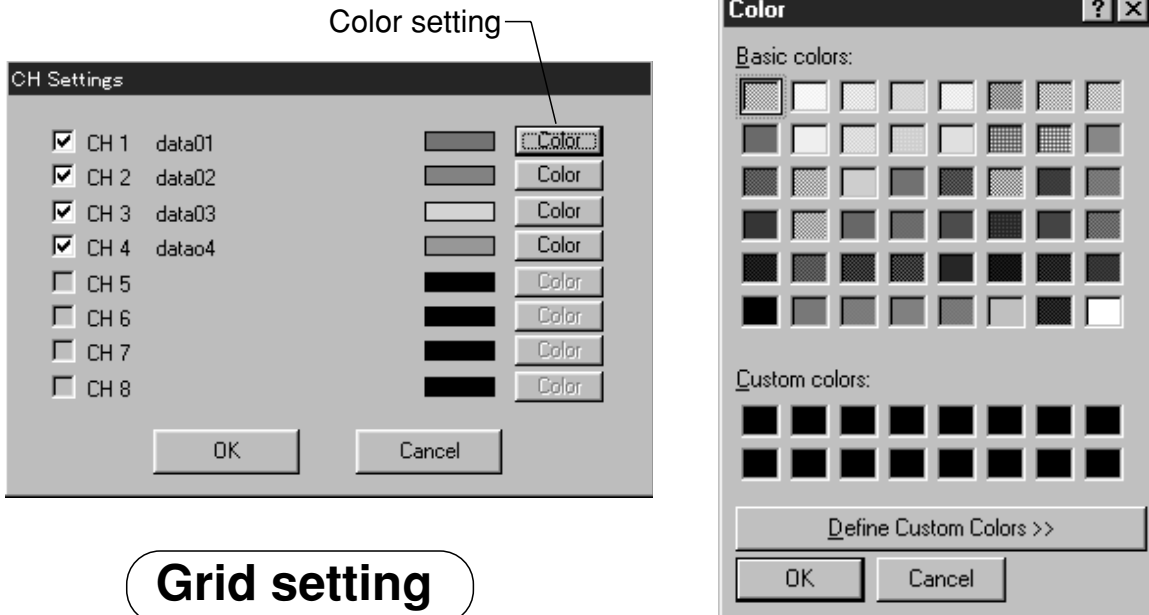

Grid setting

Display of grid lines on the graph can be turned ON/OFF. Select the Grid menu in the Graph menu from the menu bar to turn ON/OFF.

Graph copying

By selecting the Copy menu in the Edit menu from the menu bar, the displayed graph is copied to the clipboard as bit map data. The graph copied to the clipboard can be pasted to other applications, such as word processing software.

Graph printing

The displayed graph can be printed. Select the Page Setup menu in the File menu from the menu bar to set selection of printer and paper size. Select the Print menu in the File menu from the menu bar. Make necessary settings on the print screen displayed and start printing.

Chapter 4 Using the printer (for IT-550F only)

4.1 Connecting the printer

Required items:

- IT-550F main unit Printer
- Expansion kit (expansion box, modular cable)
- RS-232C connection cable

RS-232C cable selection

The IT-550F for field use is equipped with an RS-232 interface (with busy signal). It can be connected to a printer for which the following settings are possible:

- Bits per second : 2400
- Data bits : 8 start, stop bits : 1
- Parity : None

When CR function can be set, set to "CR ignore" or "Return only".
(Field type outputs CR+LF for every line.)

To connect to the field type, use the cable specified in the table below.

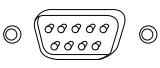
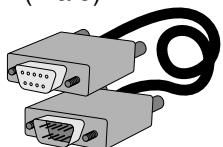
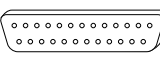
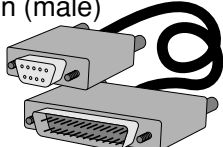
Printer model (example)	Printer side connector type	Printer side connector signal	Cable specifications
DPU-201GS (Seiko Electronics)	D-SUB 9-pin (male) 	3: Data input (DATA) 5: Ground (GND) 8: Ready to Send (BUSY)	D-SUB 9-pin (female) 9-pin (male) Extension cable 1 
DPU-411 (Seiko Electronics)	D-SUB 25-pin (female) 	2: Data input (DATA) 7: Ground (GND) 5: Ready to Send (BUSY)	D-SUB 9-pin (female) 25-pin (male) Straight cable 

- 1 Expansion box can be connected directly without using this cable.
(In this case, remove the hexagonal stay from the connector on the expansion box side.)



Caution:

Printers not equipped with an RS-232C interface cannot be used.

Connection

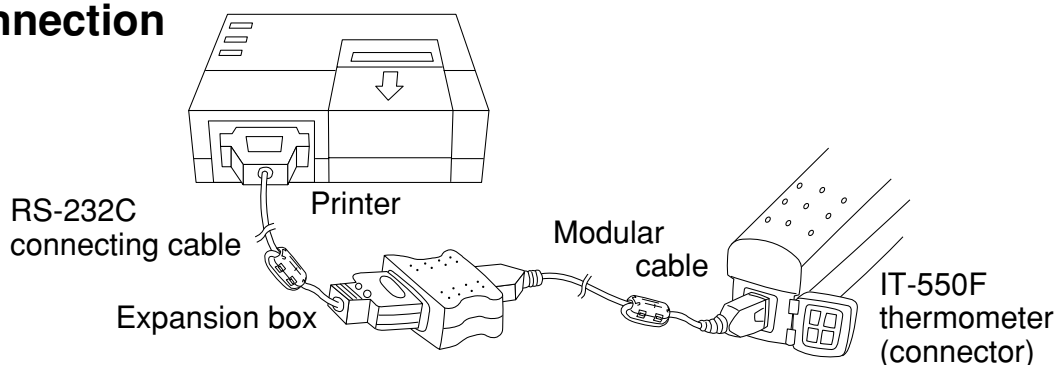

4.2 Printing thermometer memory data

1 After checking that the printer is connected to the thermometer main unit as illustrated on the previous page, turn ON the printer and thermometer main unit. Pressing the **(MEAS)** button momentarily will turn ON the main unit. The power is turned OFF automatically when no operation is performed for 15 seconds (except when printing).

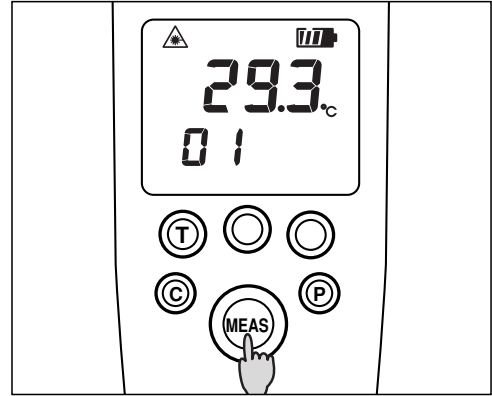

2 Pressing **(P)** button one time starts printing of the data. "Prn" blinks on the thermometer display.

Prn blinks

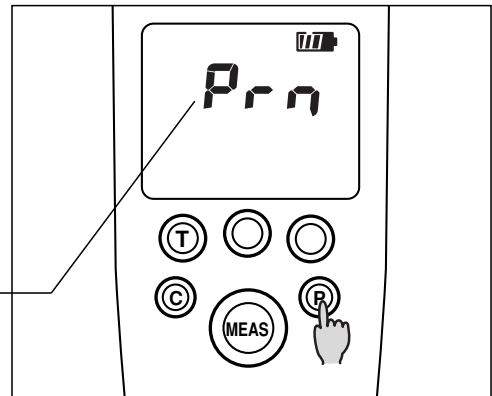

3 Memory data is sent to and printed on the printer. All memory data will be printed.

Printing example

```

PRINT 98/12/01 13:56:55
No. Date Time Temp.
01 12/01 13:51 65.4 C
01 12/01 13:51 12.9 C
01 12/01 13:51 13.1 C
01 12/01 13:51 12.1 C
01 12/01 13:51 41.4 C
01 12/01 13:51 41.3 C
02 12/01 13:51 40.7 C
02 12/01 13:51 40.3 C
02 12/01 13:51 6.0 C
02 12/01 13:51 6.6 C
02 12/01 13:51 40.6 C
03 12/01 13:52 5.7 C
03 12/01 13:52 5.6 C
03 12/01 13:52 40.8 C
03 12/01 13:52 41.3 C
03 12/01 13:52 41.5 C
04 12/01 13:52 4.3 C
04 12/01 13:52 5.0 C
04 12/01 13:52 5.1 C
04 12/01 13:52 8.1 C
04 12/01 13:52 6.1 C
05 12/01 13:52 44.3 C
05 12/01 13:52 44.2 C
05 12/01 13:52 44.2 C
05 12/01 13:52 44.4 C
05 12/01 13:52 44.6 C
10 12/01 13:54 42.3 C
10 12/01 13:54 42.3 C
10 12/01 13:55 11.3 C
10 12/01 13:55 11.4 C
10 12/01 13:55 11.2 C
15 12/01 13:55 11.4 C
15 12/01 13:55 11.2 C
15 12/01 13:55 11.2 C
15 12/01 13:55 40.7 C
15 12/01 13:55 11.1 C
    
```

5.1 Connecting the recorder

Required items:

IT-550L/S main unit

Recorder

Expansion kit (expansion box, modular cable, analog voltage output cable)

The IT-550L/S type uses an expansion box, modular cable, and analog output cable. By connecting to the recorder, it can record changes in the measured values. Analog output is 0 to 1V. Further, by setting the analog output scale of the IT-550L/S, the temperature output range to be recorded can be set.

Connecting method

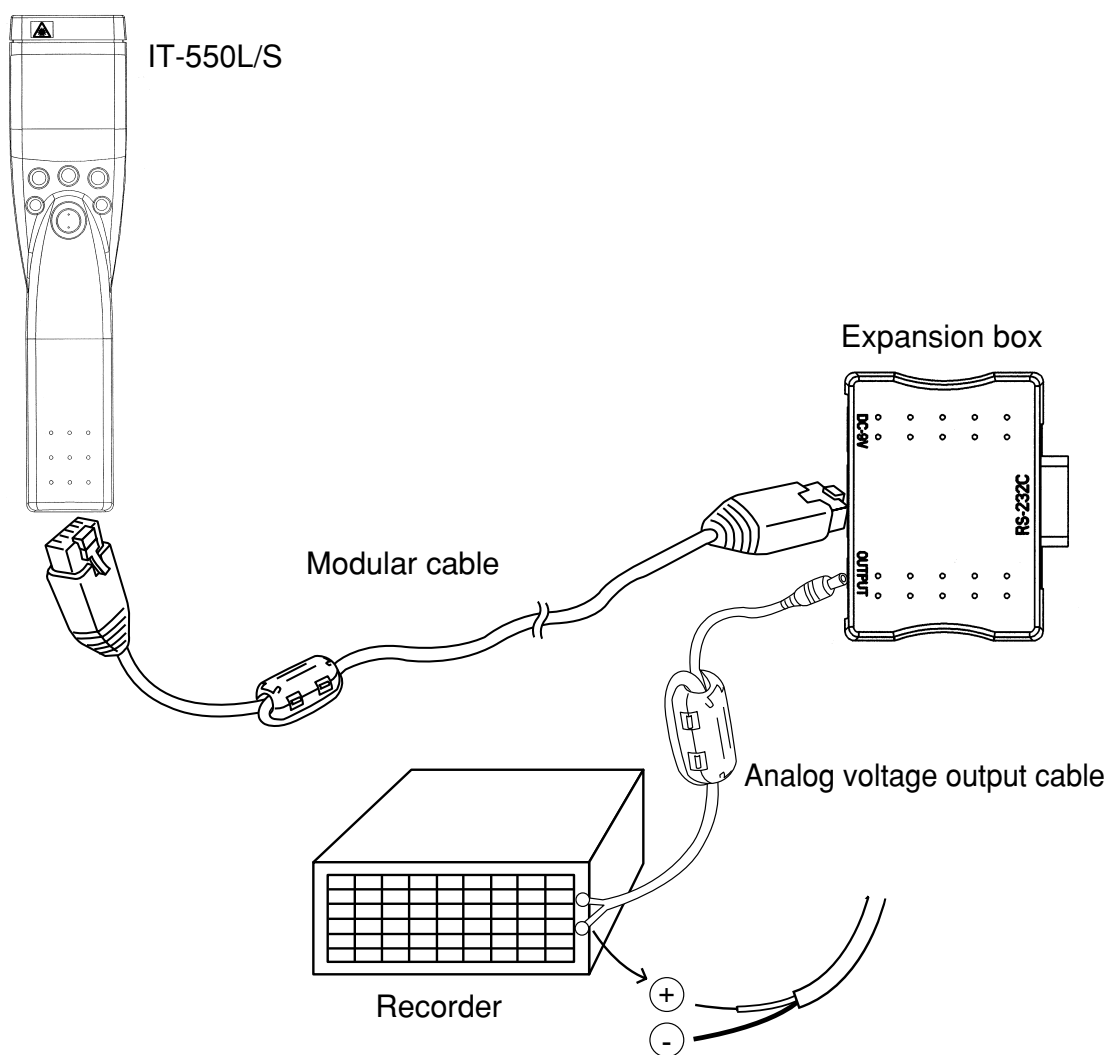

5.2 Setting analog voltage output scale

Set the analog voltage output zero (lower limit) and full-scale (upper limit) temperature.

Note:

If the ZERO set value is larger than or equal to the full-scale value, an error output (approx. 1.5V) will be output.

1 Displaying ZERO

Press the **M** button several times in the HOLD state to display ZERO. "SET" blinks.

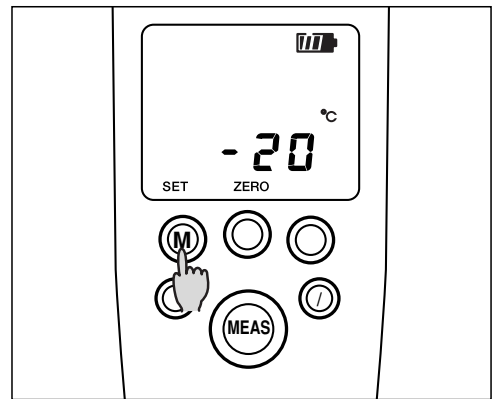

2 Changing ZERO

Figures can be changed with the **◀** or **▶** buttons.

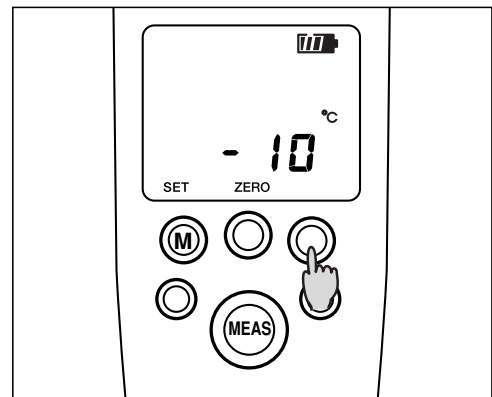

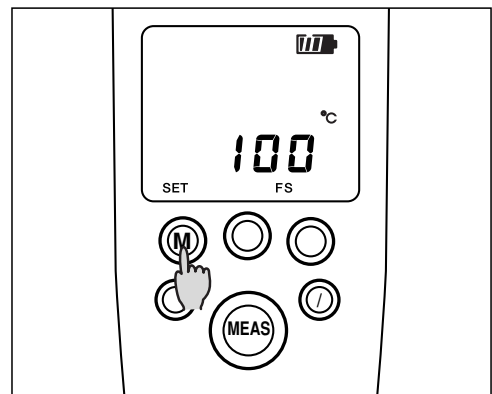

3 Displaying FULL-SCALE

Press the **M** button one time in ZERO state and display FS value. "SET" blinks.



4 Changing FULL-SCALE value

Figures can be changed with the  or  buttons.

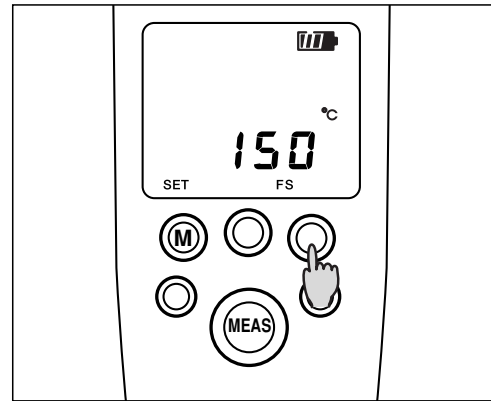

5 End setup

Pressing the  button ends setup.

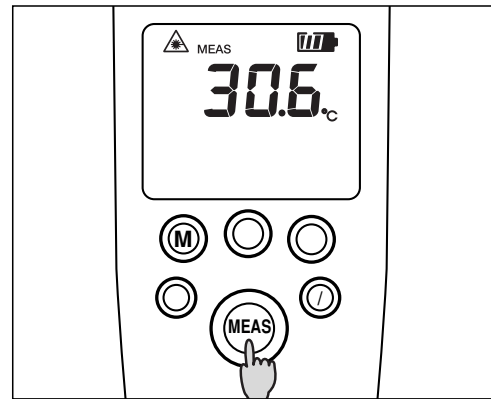

Symptoms	Causes	Countermeasures
Data is not transmitted to personal computer.	Battery of main unit is dead or not loaded.	Load new battery.
	Cable is connected incorrectly.	Connect the connector firmly.
		Check that the RS-232C cable connected to personal computer is cross connection.
	COM port is incorrect.	Change COM port setting to another port setting. Set to COM1 or COM2 with the COM Port menu in the Settings menu from the menu bar.
	Communication port of personal computer is set to "Disabled."	Change properties of communication port in your computer
	"Memory data reading" was selected on IT-550L/S.	Memory data cannot be read as IT-550L/S has no data memory function.
Printer does not print.	Printer is not turned ON.	Turn ON the printer.
	Cable is wrong.	Use the correct cable.
	Cable is not correctly connected.	Connect firmly.
Analog output is not performed.	IT-550F is connected.	IIT-550F is not equipped with voltage output.
	Setting of ZERO and FULL-SCALE is wrong.	Make correct setting.
	Range of recorder has a different setting.	Set the recorder range to 0 to 1V.

7.1 TEMP Utility specifications

IT-550F (for Field use)

No. of maximum data	Data No. 64,130 total
File operation	File reading, file writing (CVS format)
Printing	Data printing. Vertical and horizontal printing of A3, A4, B4, and B5 paper
Screen	Data No. table, data table, graph screen, and other various setting screens.
Statistics	Maximum, minimum, average values
Measured value judgment	Comparison judgment of upper limit and lower limit
Communication	Memory data reading and setting of infrared thermometer measurement through RS-232C cable are possible.

IT-550L/S (for laboratory use)

No. of maximum data	32,000 data x 8CH
File operation	File reading, file writing (CVS format)
Printing	Data and graph printing. Vertical and horizontal printing of A3, A4, B4, and B5 paper
Screen	Data CH table, data table, graph screen, real-time measurement screen, other various setting screens
Graph display function	8CH simultaneous display, time axis, temperature axis scale change and zooming Two-cursor display, cursor data display, calculation of data between cursors
Edit	Copying graph screen to clipboard
Statistics	Maximum, minimum, average values
Communication	Setting of real-time measurement and infrared thermometer measurement through RS-232C cable are possible.

7.2 Communication specifications

An operator who has a special knowledge of measurement using a personal computer can transmit or receive the set values or measured values of the IT-550 using the host computer.

Use the following specifications and communication method as a reference.

(1) RS-232C communication specifications

Bits per second : 2400

Data bits : 8 Start, stop bits : 1

Parity : None

Flow control by hardware: CTS is valid when output to printer by switch operation. CTS is ignored for other cases.

Echo back: ON/OFF switching possible. (OFF when power is ON)

(2) Communication method

When a valid command (+ operand) is received from the host computer (refer to table below), the IT-550 transmits the response. It does not respond to character strings that are not defined as a command.

The IT-550 does not distinguish capital letters and small letters of command and operand.

When "]" is received, the IT-550 clears reception buffer and turns OFF echo back.

When "[" is received, the IT-550 clears reception buffer, turns ON echo back, and returns "[".

Function	Command, operand	Response
Measurement start, measured value request	"."	Start message or instantaneous measured value
Hold, measured value request	","	Hold message or hold value
Emissivity setting	"E [x.xx]"	Emissivity set value Setting is valid only at holding.
Clock setting	"T [hh:mm:ss]"	Present time (see note 1)
Year, month, day setting	"D [yy/mm/dd]"	Year, month, day (see note 1)
Memory data request	"M"	Memory data or "No Data" (see note 1)
Memory data clear	"CLR"	Clear completion message or "No Data" Valid only at holding (see note 1)
Measurement resolution switch setting	"R [rr]"	Measurement resolution (see note 2)
Analog output zero point setting	"Z [xxx]"	Output zero set value (see note 2)
Analog output full-scale setting	"F [xxx]"	Output full-scale set value (see note 2)
Power OFF	"OFF"	Power OFF message
Backup to non-volatile memory ^o	"BKUP"	Backup message

[]: Omission is possible. If omitted, present set value is returned.

xxx: Figure of decimal system rr: "1" or "0.1"

note 1: Function limited to IT-550F (Operation is not guaranteed for IT-550L/S.)

note 2: Function limited to IT-550L/S (Operation is not guaranteed for IT-550F.)

HORIBA ,Ltd.

Miyanohigashi, Kisshoin, Minami-ku, Kyoto, Japan

Phone : (81)75-313-8123 Telex : (54)22130 Fax.: (81) 75-321-5725