

Flow sheet

VA-5111+VS-5001

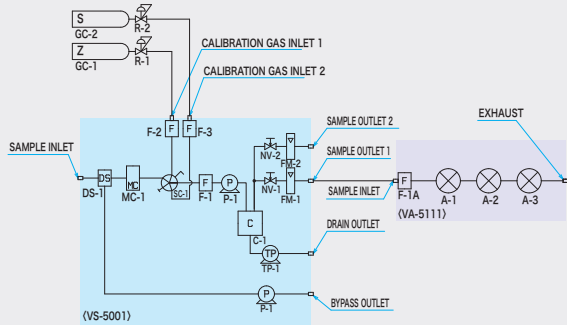

VA-5113+VS-5002

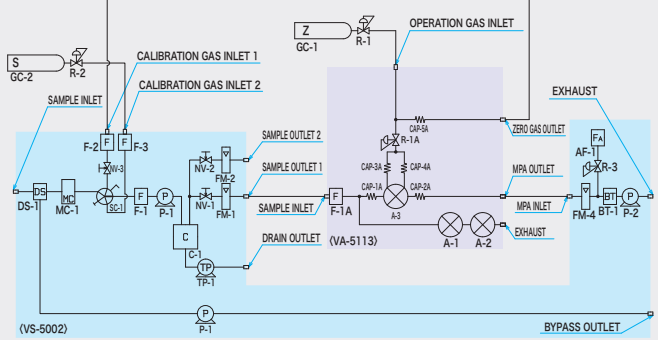

VA-5112+VS-5003

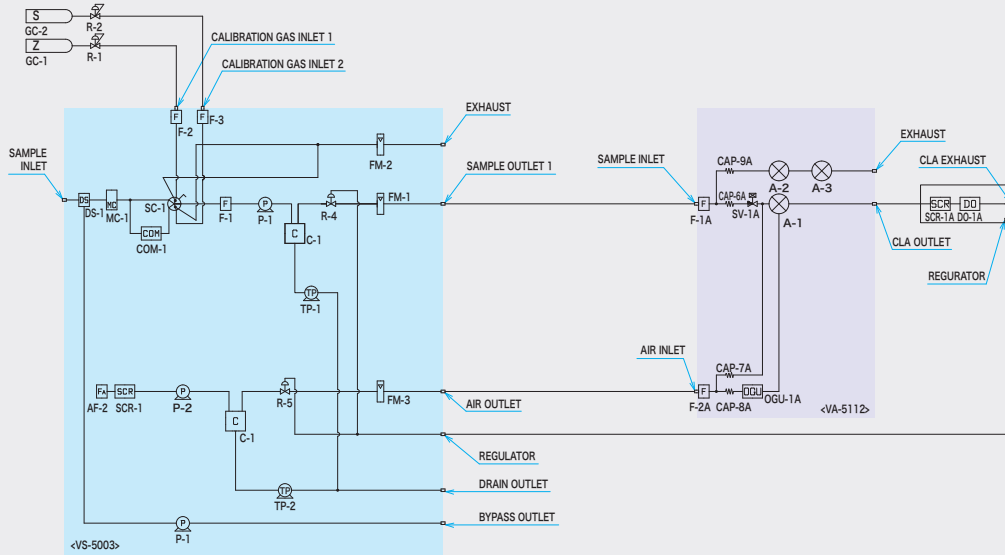

VA-5123+VS-5004

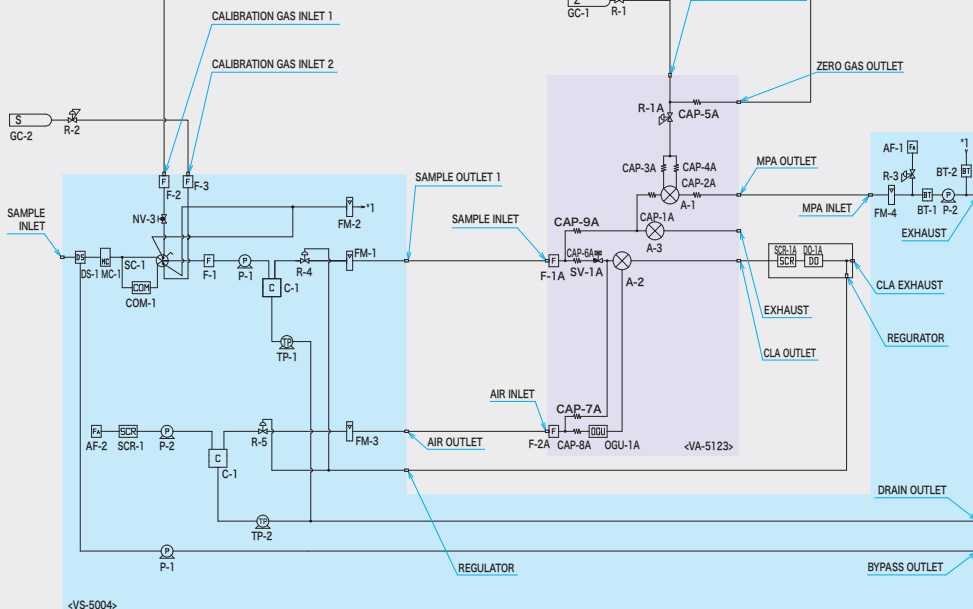

Legend	
A	: Analyzer Unit
AF	: Air Filter
BT	: Buffer Tank
C	: Thermo-electric Dehumidifier
CAP	: Capillary
COM	: Converter
DO	: Deozone
DS	: Drain Separator
F	: Filter
FM	: Flowmeter
GC	: Gas Cylinder
MC	: Mist Catcher
NV	: Needle Valve
OGU	: Ozonizer
P	: Pump
R	: Pressure Regulator
SC	: Selector Valve
SCR	: Scrubber
SV	: Solenoid Valve
TP	: Tubing Pump