



Scientific diffraction gratings / Custom gratings

Product catalog and capabilities

Commitment to quality



HORIBA Jobin Yvon offers complete customer service, including expert technical advice for optimizing system configurations to meet customers' needs.

HORIBA Jobin Yvon is ISO 9001:2000 certified, and our well-staffed departments are committed to customer satisfaction and product quality.

Scientific diffraction gratings

Introduction	2	Ion-etched gratings for vacuum UV and soft X-ray applications	20
Advanced technologies for grating production	3	Holographic ion-etched lamellar master gratings for synchrotron and soft X-ray applications	20
Holographically recorded gratings	3	Toroidal ion-etched holographic master gratings for VUV applications	22
Ion etching	5	Variable Groove Depth (VGD) master gratings for XUV application	22
Mechanical ruling	6	High-grade mirrors for VUV and XUV applications	25
High precision replication	6	Holographic plane gratings	26
Production facility	7	Blazed holographic plane gratings	28
Custom gratings	8	Holographic concave gratings - Type I	29
Gratings for laser pulse compression	9	Flat field and imaging gratings - Type IV (aberration corrected gratings)	30
Gold coated master pulse compression gratings	9	Monochromator gratings - type IV (aberration corrected gratings)	30
Replica gratings for pulse compression	12	Monochromator gratings - Type IV	32
Multi-layer dielectric gratings for pulse compression	13	Custom, aberration corrected, concave gratings	32
Transmission gratings for high energy lasers	15	Ruled plane gratings	34
The Laser Megajoule (LMJ) gratings	15	Dye laser gratings	36
Specifications of the LMJ transmission gratings	15	Coatings	37
Reflection grisms for material dispersion compensation	16	Gratings and mirrors	37
Pulse compression with negative GVD and negative TOD	16	Ordering information	37
Gratings for astronomy and space experiments	17	VUV & soft X-ray gratings	37
Holographic master and replica gratings	17	HJY divisions and product lines	38
Bulk transmission gratings for astronomy	19	Information request	40

Introduction

HORIBA Jobin Yvon
 16-18, rue du Canal
 91165 Longjumeau Cedex
 FRANCE

tel.: +33 (0)1 64 54 13 00
 Fax: +33 (0)1 69 09 93 19

As a pioneer and world leader in the field of diffraction gratings, HORIBA Jobin Yvon continues to develop advanced manufacturing processes for scientific/custom diffraction gratings and optics.

Founded in 1819, HORIBA Jobin Yvon has defined the leading edge of optics for spectroscopy for over 180 years. Our leadership in optics has been demonstrated by the continuing development of both ruled and holographic grating technology, including the invention of aberration-corrected holographic gratings and ion-etched blazed holographic gratings.



HORIBA Jobin Yvon's scientific/custom diffraction gratings are found in cutting-edge scientific applications including ultrafast lasers, space flight instruments, astronomy, and synchrotron spectrometers. In addition, our high-volume replicated gratings are used in OEM instruments including spectrophotometers, bioanalyzers, and colorimeters. HJY's gratings for high volume OEM instruments can be found in our OEM Gratings catalog, while this catalog focuses on diffraction gratings for scientific and research applications.

HJY's scientific gratings are either masters or replicas, depending on the application. HORIBA Jobin Yvon also produces custom diffraction gratings, which can be specified according to our customers' unique technical requirements.

Contact your HJY representative for assistance with choosing the right grating for your application.

our website: www.jobinyvon.com

Advanced technologies for grating production

A diffraction grating is produced by first ruling a master grating. We can then replicate this master into a large number of exact copies, called replicas, for cost savings and product consistency.

Master gratings are manufactured using the following technologies:

- Holographic recording
- Ion-etching of holographic master
- Mechanical ruling

Holographically recorded gratings

The era of modern holography began in the 1960s with the use of lasers as coherent light sources. In 1967 the HORIBA Jobin Yvon engineering team, led by J. Flamand and A. Labeyrie, produced the first holographically-recorded diffraction gratings. Intensive R&D efforts led to HJY's production of holographically-produced aberration-corrected gratings, for which the company was awarded numerous international patents.

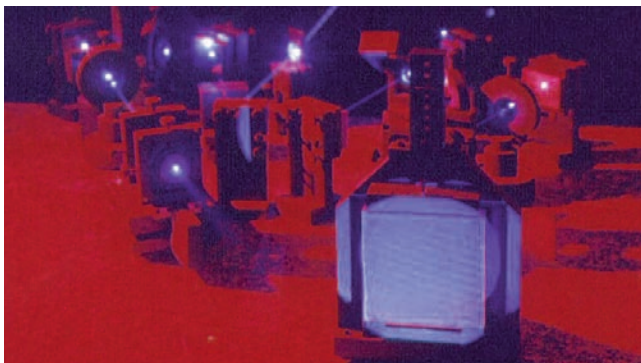

Holographic recording setup

To manufacture holographic gratings, highly-polished and precisely-figured blanks (exceeding $\lambda/10$ for many applications) are coated with a layer of photosensitive material, which are then exposed to fringes created by the interference of two coherent laser beams. Chemical treatment of the photosensitive layer selectively dissolves the exposed areas of the photoresist layer, forming grooves in relief.

Through careful design and configuration of the holographic recording apparatus, we can obtain plane

and concave "Type I" gratings (parallel grooves, uniformly spaced), or "Type IV" gratings with variable-spaced grooves for full aberration correction. Optimization of the holographic recording geometry requires optomechanical stability far greater than most optical applications.

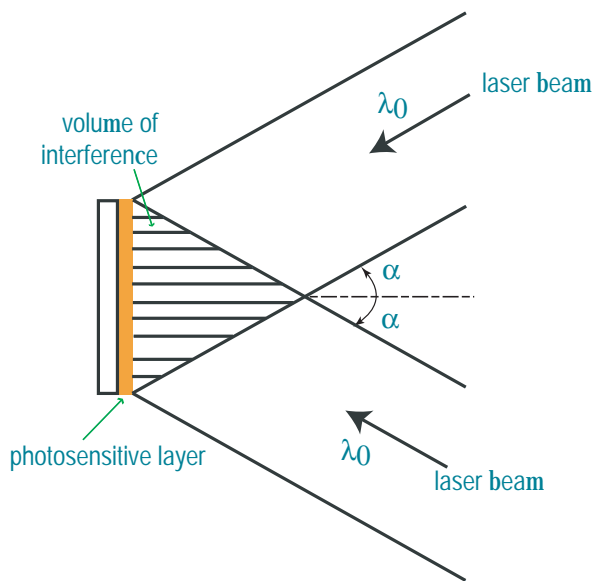

Recording a plane holographic grating with straight and equidistant grooves: type 1

The shape of the grooves produced by holographic recording is typically sinusoidal or pseudo sinusoidal.

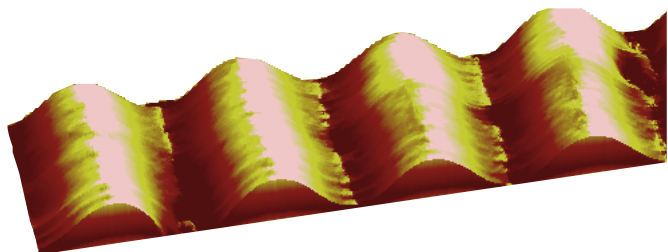

Sinusoidal profile - AFM image

Signal-to-noise ratio of holographic gratings

In many applications, the most important system parameter is the signal-to-noise ratio. The signal level is proportional to light collection properties and efficiency of the grating. For a classically ruled grating, the noise arises from ghosts (associated with periodic errors in the lead or pitch of the high precision screw), and from stray light due to random, non-periodic surface defects and the roughness of the reflecting surfaces.

Holographic recording produces grooves that are perfectly equi-spaced, completely eliminating all ghosts due to periodic errors. The overall quality of the grating surface is such that imperfections and roughness are considerably less than those found in classically ruled gratings, thus reducing stray light. In addition, the holographic technique is well-suited for producing large numerical aperture concave gratings (F/2 or even more).

As a result, holographic gratings generally present a much higher signal-to-noise ratio compared to classically ruled gratings.

Type I, plane and concave gratings

For the production of plano and concave Type I holographic gratings, the two recording beams are collimated and oriented symmetrically with respect to the grating normal. Gratings produced in this manner have grooves which are parallel with a constant pitch.

We produce Type I grating masters for many applications, including high-energy ultrafast lasers, space-flight and astronomy, and vacuum ultraviolet systems, and we produce Type I replicas for general spectroscopic applications. Large-aperture holographic gratings are routinely produced in our laboratories, up to 500 mm in dimension.

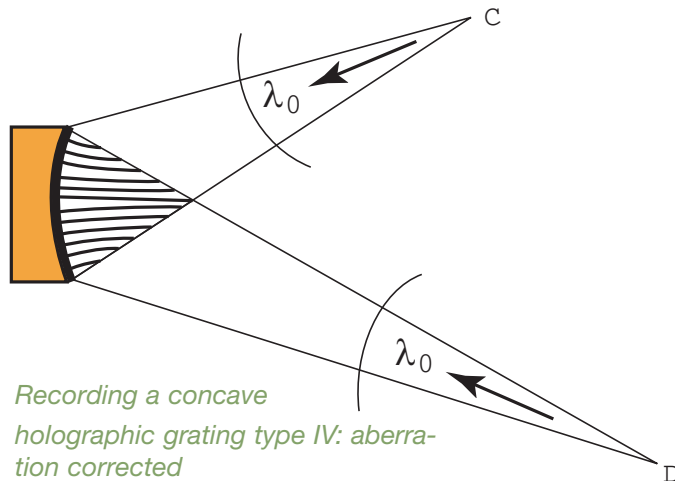

Recording a concave holographic grating type IV: aberration corrected

Type IV, aberration corrected gratings

Type IV aberration-corrected gratings are typically recorded using two point sources. As a consequence, the grating grooves are no longer straight and parallel, but instead correspond to confocal hyperboloids or ellipsoids. Optimizing the position, angles and arm lengths of the two sources provides the optical designer with the degrees of freedom necessary to minimize aberrations, typically astigmatism and coma. Auxiliary optics such as gratings provide the optical designer with additional flexibility for recording more specific groove patterns and distributions (see US patent 4842353 “Diffraction apparatus with correcting grating and method of making,” A.Thevenon et al., for a description of our methods).

Type IV aberration-corrected gratings have become the dispersive element of choice in many spectroscopic systems, as they require no other optics in the instrument for imaging or focusing. These gratings are used in various configurations, including monochromator, spectrograph and monograph (scanning spectrograph) systems.

Using this technology, HJY has designed several new grating types for specific applications: **Type IV, Aberration Corrected, Flat Field and Imaging Gratings:** These concave gratings disperse, collimate and refocus light from the entrance slit onto a plane surface; these gratings are well-suited to take advantage of solid-state detectors with either a linear or 2D array of independent photo-sensitive elements.

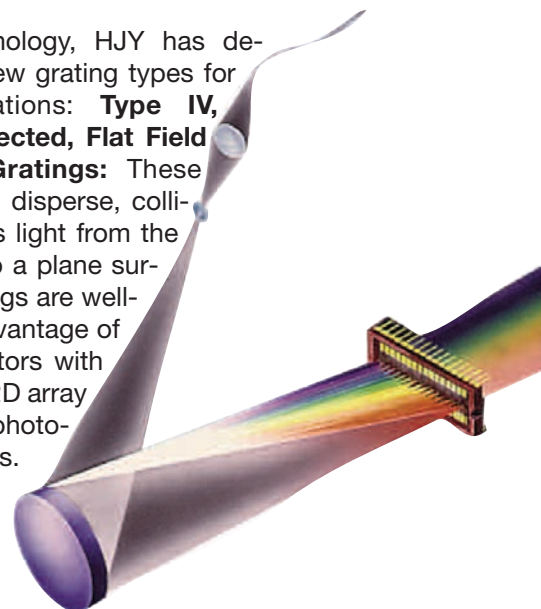

Type IV, Aberration Corrected, Monochromator Gratings: these concave gratings are specifically designed for use with an entrance slit and an exit slit. Wavelength scanning is performed by a simple rotation of the grating.

*H1061
monochromator*

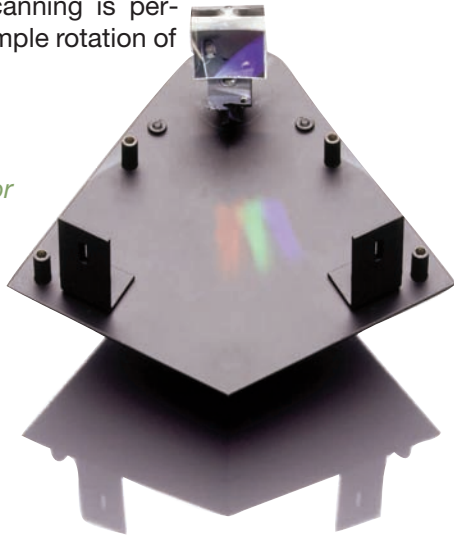

Variable Line Spacing Gratings (VLS gratings) for Vacuum UV applications: Gratings and mirrors used in the far vacuum UV and soft X-ray regimes must be operated in grazing incidence, to enhance the reflectivity of the coatings. The considerable astigmatism of traditional Type I concave gratings at grazing incidence results in low signal throughput at the instrument exit slit. To correct astigmatism and coma in this difficult case, HJY has developed specific aberration corrected plano and concave holographic gratings, which present a variation of the groove density according to a specified polynomial law (VLS gratings).

HJY optical engineers will recommend a standard Type IV aberration-corrected grating or will custom-design a specific aberration-corrected grating to maximize performance for a given application.

Ion etching

Ion etching allows the shape of the grooves on a holographic master grating to be “sculpted” as needed for an application. It is possible to produce blazed holographic gratings with different groove shapes, including triangular and laminar profiles.

The technique uses an ion etching system to mill surface atoms through a holographic mask. This holographic mask is formed by the illumination, and subsequent chemical processing, of a laser generated interferogram in photoresist. The process is compatible with plano, spherical, and aspheric substrates



*Initial pseudo sinusoidal,
holographically recorded groove profile*

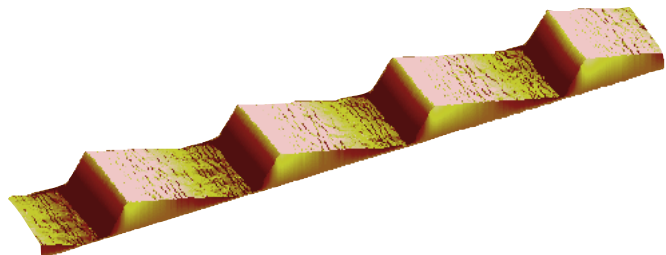

*Triangular holographically recorded and ion etched
groove profile*



*Laminar holographically recorded
and ion etched groove profile*

Ion-etched ‘sawtooth’ profiles enhance efficiency at the blaze wavelength in the first order, as well as in the higher diffraction orders. Laminar groove profiles can be designed to minimize or nearly eliminate undesirable second-order efficiency.

Ion-etched gratings can be replicated for quantity production, but they are often used directly as master gratings. In this case the grating grooves are ion-etched directly in the blank itself, resulting in a grating which is very robust, even under the extreme illuminations of the most intense synchrotron light sources.



Mechanical ruling

Classically-ruled master gratings are produced by first evaporating a coating of gold or aluminum onto a highly-polished substrate, and then mechanically burnishing triangular grooves using a precision diamond tool.

The incredible specifications required for the ruling of gratings demand such a high degree of technology, that few facilities in the world are able to produce them. The ruling engines at HJY are among only 10 to 15 successfully operating ruling engines in the world today.

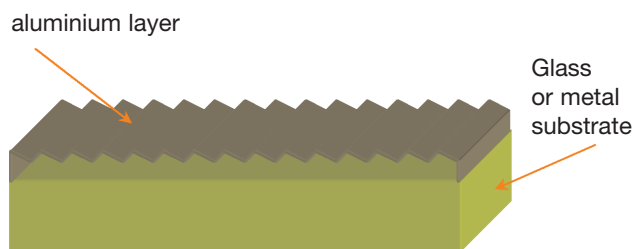

The most important requirement of the ruling engine is that the diamond carriage follows an exact path on each stroke. Any lateral displacement will introduce an error in the groove spacing of the finished grating. The carriage rides on perfectly-smooth tracks, under the very precise control of a heterodyne laser interferometer which controls the carriage displacement in order to maintain absolute parallelism and displacement accuracy.

Finally, the exact profile of the groove must be faithfully maintained across the entire surface of the grating. Any wear of the ruling tool during the course of operation must be compensated; an Atomic Force Microscope (AFM) is devoted to this control.

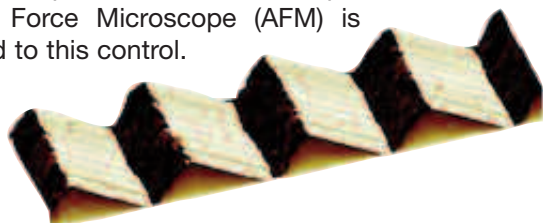

Diamond ruled sawtooth profile

Given the difficulties (and associated high costs) of ruling a grating, most of the gratings used in instruments are more-affordable replicas of the directly ruled master grating.

HORIBA Jobin Yvon has one of the widest inventories of ruled masters from which we produce high precision replicas.

High precision replication

Once a master grating has been manufactured according to the techniques previously described, it can be replicated to produce exact copies of the original. A replica blank of high optical quality is coated with a layer of epoxy and “sandwiched” together with the master. When the epoxy is cured, the master and replica are separated and the epoxy layer remains attached to the replica substrate. The epoxy layer is now an exact copy of the grooves of the master, and this replica can now be coated with a reflective layer using vacuum deposition. It is possible to replicate gratings with many different shapes, including spherical and mildly aspheric surfaces.

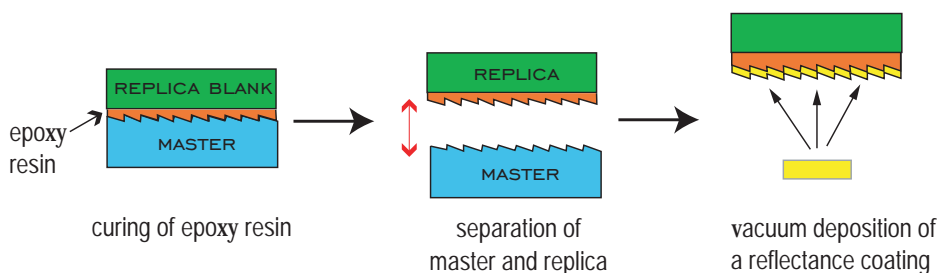

The replication process is highly accurate. Replica gratings retain the diffracted wavefront, efficiency, and stray light characteristics of the master to a very high degree.

The reproducibility of replica gratings makes them ideal for high-volume production, and for scientific experiments in which a smaller quantity of absolutely identical gratings are required.

Production facility

HORIBA Jobin Yvon has two grating manufacturing facilities, in Longjumeau, France (near Paris) and in Edison, New Jersey (USA). Between these facilities HORIBA Jobin Yvon possesses a wide array of technological resources for grating manufacturing and metrology:

- Holographic recording (to half-meter dimension)
- Ion etching for small and large size gratings
- Ruling engines
- Large vacuum coating (equipment)
- Optical polishing, with highest specifications in slope error and microroughness
- Grating metrology tools, including atomic force microscopes, interferometers, efficiency measurement systems, and microroughness measurement systems
- 2 operational replication facilities

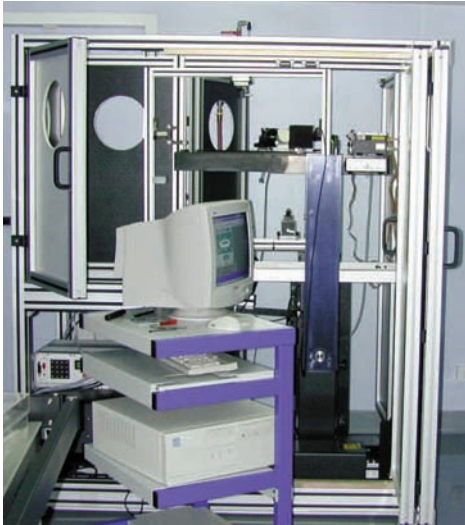

Quality control: efficiency measurement



Grating facilities are installed in high class cleanrooms

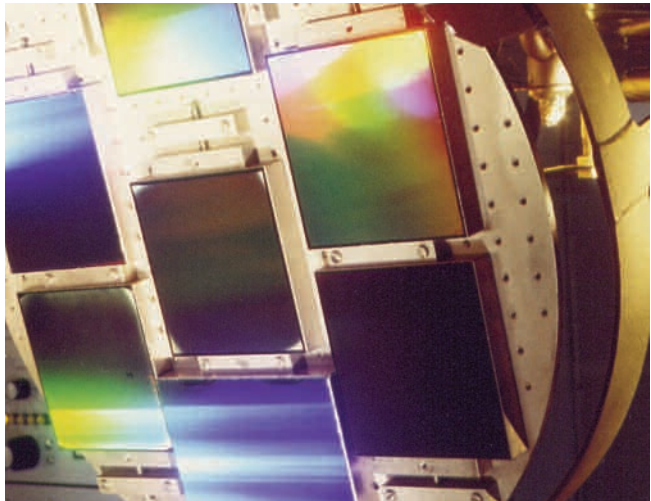

Quality control: microroughness measurement

Custom gratings

The Custom Gratings division of HORIBA Jobin Yvon addresses the needs of the scientific community for very specific, high-performance diffraction gratings. This group excels in designing and manufacturing challenging diffraction gratings for applications including space flight, astronomy, laser pulse compression, high energy lasers, and synchrotron sources.

For over 40 years, HORIBA Jobin Yvon has played a leading role in the design, development and manufacture of master and replica custom diffraction gratings for laboratories throughout the world.

Our recent groundbreaking work such in the development of large, high-efficiency, high-energy transmission gratings for the French MegaJoule Laser program is one well-publicized example of HJY's long tradition of innovation in the field of diffraction grating technology.

In the field of Space Science, HJY is regularly selected by NASA and ESA to provide gratings for the most demanding missions.

A full team of HORIBA Jobin Yvon optical engineers is dedicated to supporting our customers' design efforts, and to help optimize custom gratings for specific applications. Our extensive experience, combined with our strong optical modeling capabilities, allows us to partner with our customers and provide the best solution for performance and cost.

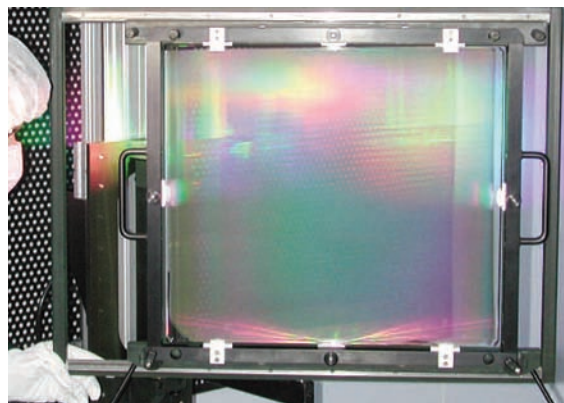

90% high efficiency transmission grating, 420x470 mm size

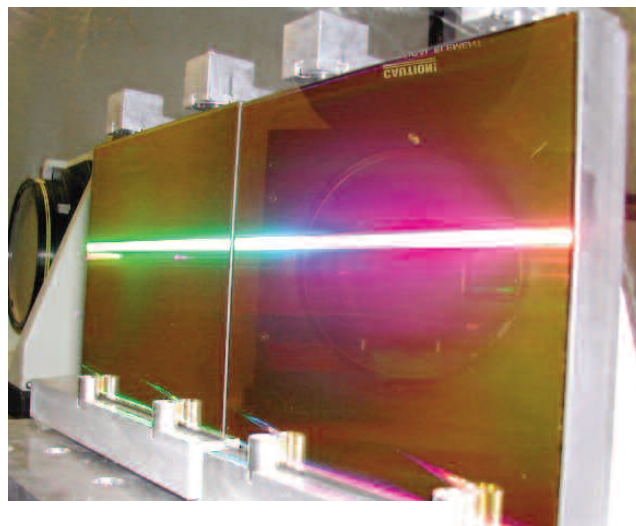

Laser pulse compression gratings optimized for tiling

Custom gratings

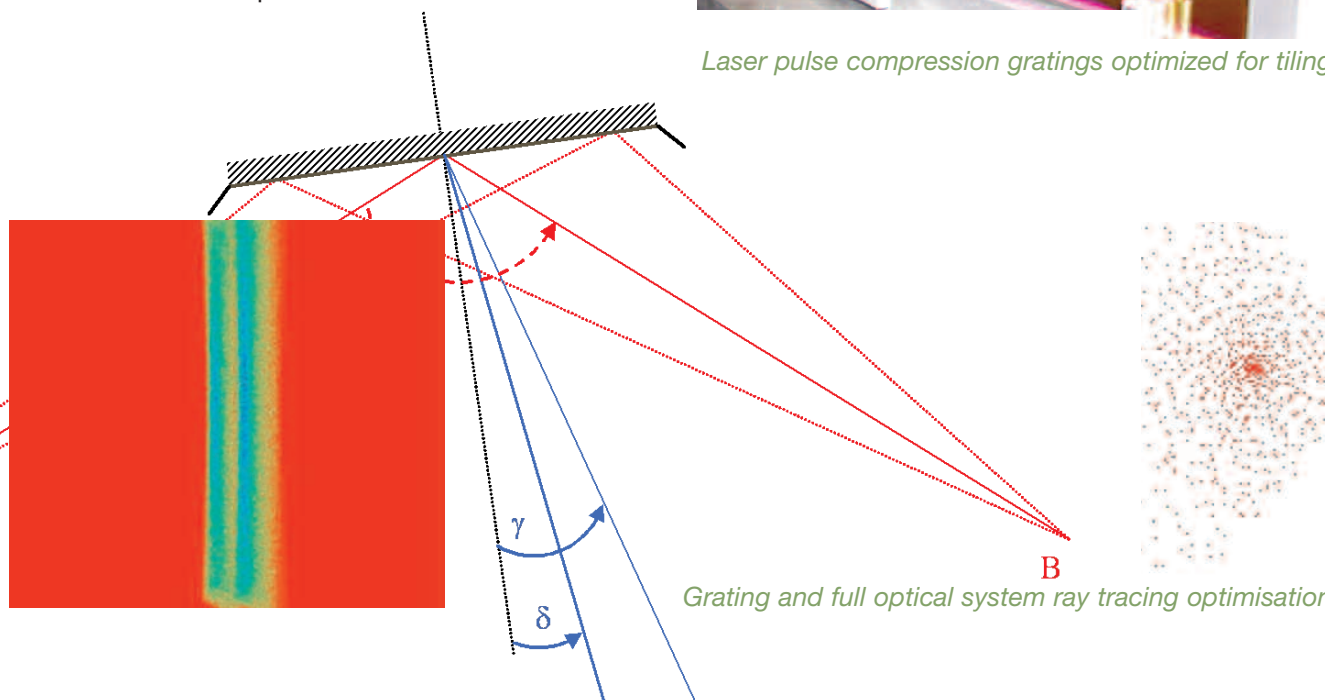

Grating and full optical system ray tracing optimisation

Gratings for laser pulse compression

Gold coated master pulse compression gratings

Diffraction gratings are widely used for pulse compression in Chirped Pulse Amplification (CPA) laser systems. High diffraction efficiency, high wavefront quality and high damage threshold are essential characteristics for these gratings.

HORIBA Jobin Yvon has pioneered the design and development of pulse compression gratings using holographic techniques. By carefully designing the grating groove parameters, gold-coated pulse compression gratings can achieve diffraction efficiencies as high as 94% at either 800 nm or 1 053 μm. In addition, the holographic manufacturing technique can produce very large gratings that demonstrate an excellent stability and quality of the diffracted wavefront.

Master pulse compression gratings

In CPA lasers where the highest optical performance and damage thresholds are required, a master gold-coated holographic grating ensures best performance. Master gratings are the technology of choice for large-area gratings, and HJY currently supplies several standard sizes up to 210x420 mm. Standard groove densities include 1200, 1480, 1740 and 2000 lines/mm, for operation at 800 nm or 1053 nm. Custom sizes can be considered up to 500x500 mm, and alternate groove densities, non-standard wavelength optimization, and/or larger grating sizes will be reviewed upon request.

tom sizes can be considered up to 500x500 mm, and alternate groove densities, non-standard wavelength optimization, and/or larger grating sizes will be reviewed upon request.

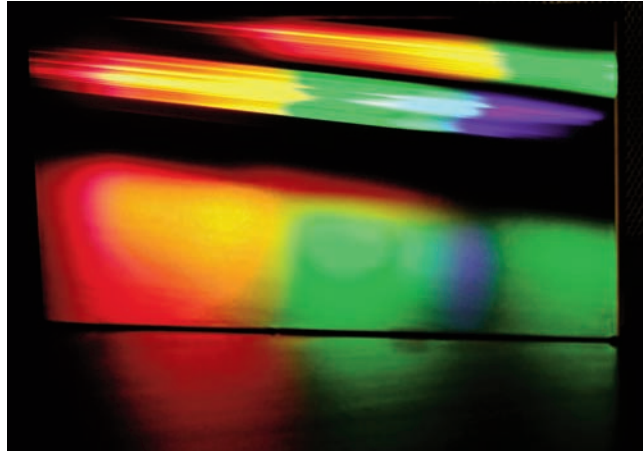

FEATURES

- Optimized holographic ruling
- Gold layer coating
- Highly polished blanks
- Large range of standard and custom sizes for all groove densities

BENEFITS

- High diffraction efficiency with minimal light absorption
- High damage threshold
- Maintains wavefront quality
- Can be matched to your compression and pulse energy requirements.

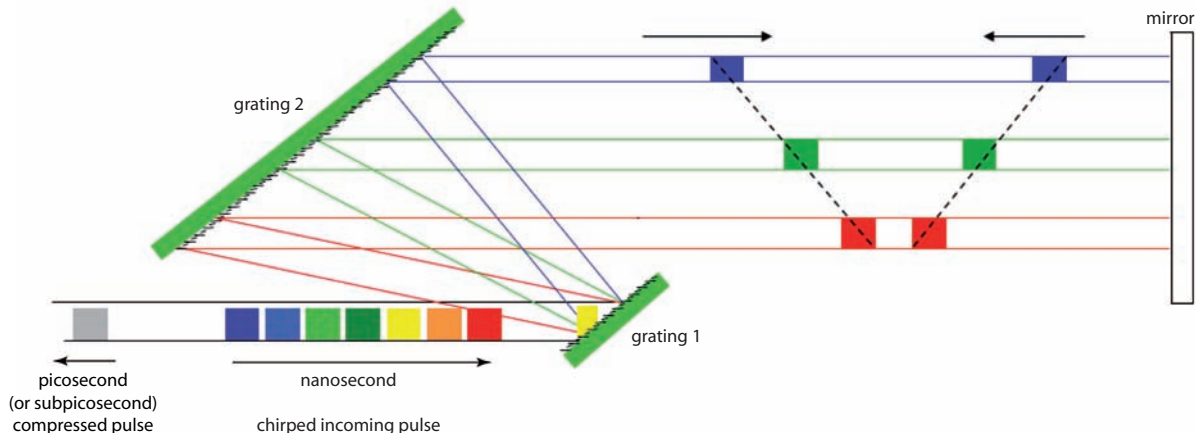

Gratings for laser pulse compression

Typical holographic master efficiencies for pulse compression

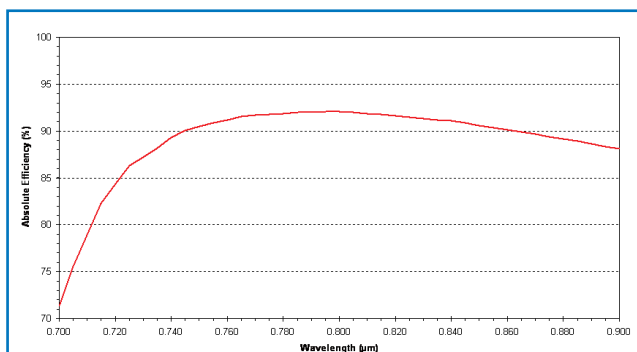

1200 g/mm, 800 nm, deviation=10°, TM, Au coating

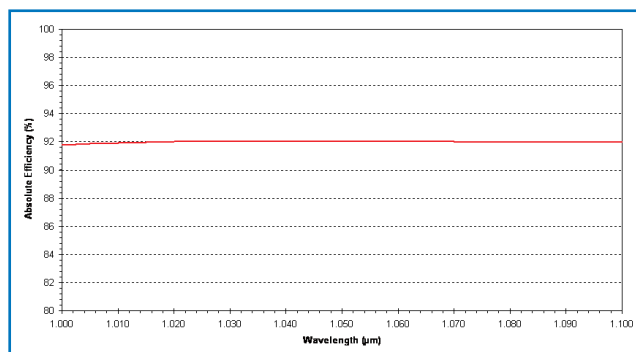

1200 g/mm, 1050 nm, deviation=10°, TM, Au coating

NOTE:

These efficiency curves are absolute theoretical efficiencies, calculated using rigorous electromagnetic theory, taking into account the true groove profiles of manufactured gratings measured with an atomic force microscope (AFM). These curves are for reference only and do not indicate grating specifications. These efficiency curves are calculated with constant deviation angle of 10°

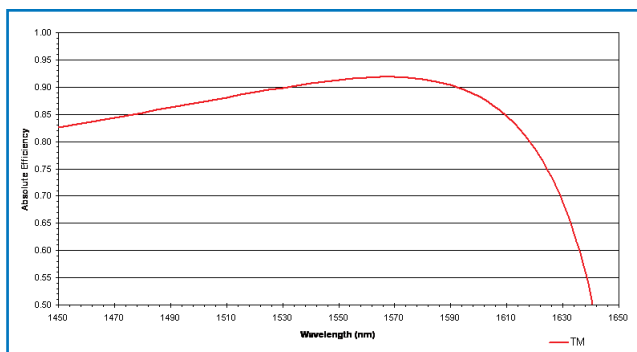

1200 g/mm, 1550 nm, deviation=10°, TM, Au coating

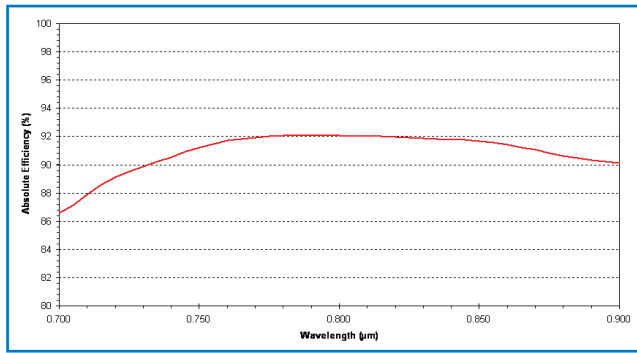

1480 g/mm, 800 nm, deviation=10°, TM, Au coating

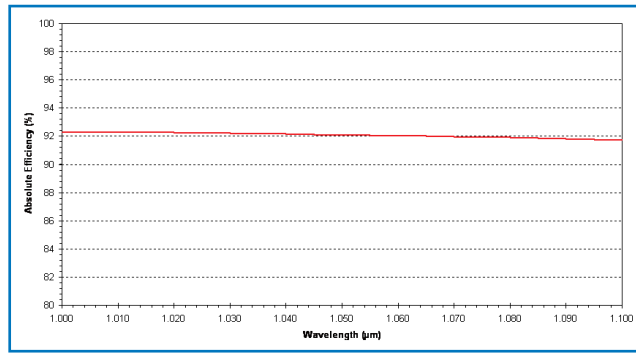

1480 g/mm, 1050 nm, deviation=10°, TM, Au coating

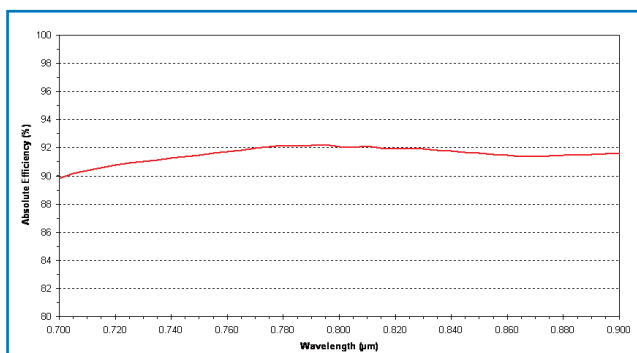

1740 g/mm, 800 nm, deviation=10°, TM, Au coating

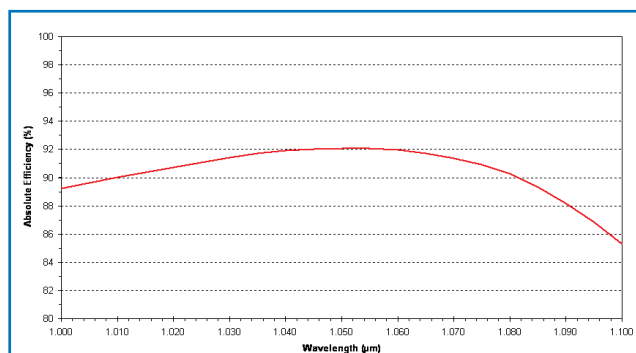

1740 g/mm, 1050 nm, deviation=10°, TM, Au coating

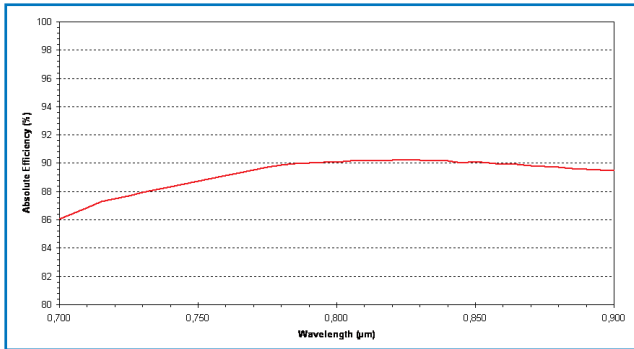

1800 g/mm, 800 nm, deviation=10°, TM, Au coating

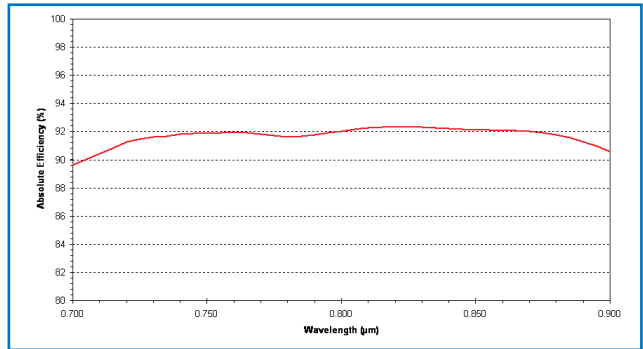

2000 g/mm, 800 nm, deviation=10°, TM, Au coating

Diffraction efficiency according to incident angle

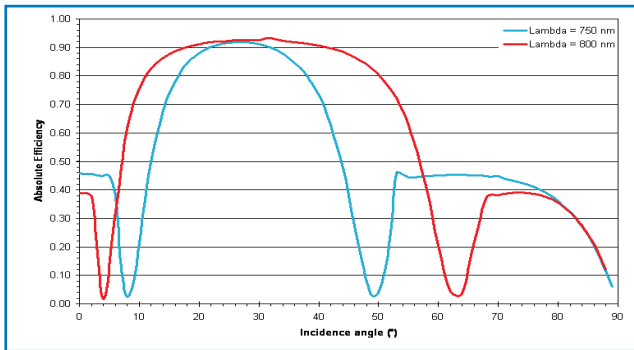

1200 gr/mm, 750nm and 800 nm, variable incidence, TM, Au coating, Littrow angle = 28.7° at 800 nm

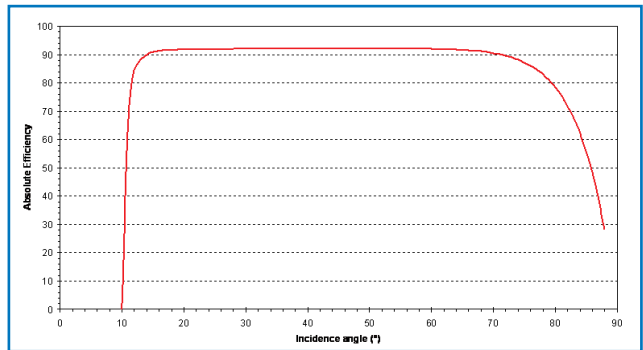

Typical absolute efficiency vs Incidence Angle
1480 gr/mm, coating Au, wavelength = 800 nm, TM

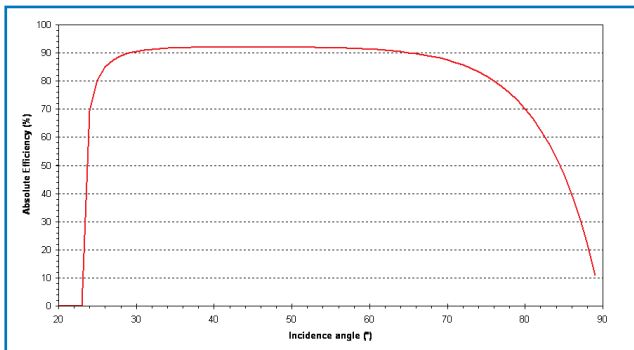

Typical absolute efficiency vs Incidence Angle
1740 gr/mm - coating Au, wavelength = 800 nm, TM

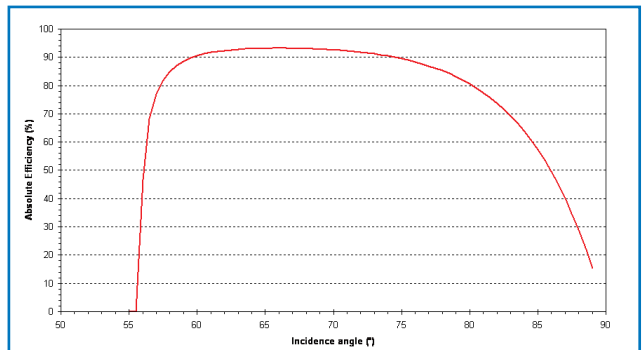

Typical absolute efficiency vs Incidence Angle
1740 gr/mm, coating Au, wavelength = 1050 nm, TM

The efficiency can vary significantly depending upon the user geometry.

Efficiency values depend primarily on deviation angle (angle between incident beam and diffracted beam). In general, if deviation angle does not exceed 15°, the efficiency and bandpass remain stable, if deviation angle exceeds 15°, a careful evaluation is necessary (see 1200 gr/mm grating variable incidence effi-

ciency curve example). For the same deviation angle, bandpass depends on the incidence angle being smaller or larger than the Littrow angle (less or more grazing incidence angle). In general more grazing incidence angle is more favorable for the bandpass.

Guaranteed specifications:

Efficiency:

90% average absolute efficiency on TM polarisation, at 800 nm or 1053 nm in near-Littrow configuration (10° deviation angle between the incident and diffracted beams)

Exception: for 1800 l/mm grating, optimised at 1.06 micron, our warranty is 85% average absolute efficiency

Wavefront quality:

Better than $\lambda/4$ at 800 nm or at 1 053 nm in the -1 diffracted order

Ruled area:

Please find the warranted ruled areas according the substrate size:

size code	blank size	warranted ruled area
090	40x60x10	36x56
160	80x110x16	76x106
180	110x110x16	106x106
200	120x140x20	115x135
208	135x175x30	125x165
223	165x220x30	155x210
505	190x350x50	180x340
525	210x420x50	200x410

Substrate material

Standard substrate material can be fine annealed pyrex or ULE depending on application, size and availability.

It may be of interest for high repetition rate laser in order to avoid any temperature effect on laser stability.

Very large size PCG grating

On request we can produce large size Gold Coated PCG gratings for example: 300x485x50 mm or 360x565x50mm

Delivered documentation with master pulse compression gratings

For large gratings (165x220 mm and larger):

- Absolute efficiency, measured in nine spots distributed over the clear aperture of the grating
- Interferograms of -1 order and 0 order wavefronts
- A certificate of conformity

For small gratings:

- Absolute efficiency, measured in the center of the grating
- Quality of the -1 order diffracted wavefront
- A certificate of conformity

		40x60x10	80x110x16	110x110x16	120x140x20	135x175x30	165x220x30	190x350x50	210x420x50
1200 l/mm	750 - 850 nm	524 26 090	524 26 160	524 26 180	524 26 200	524 26 208	524 26 223	524 26 505	524 26 525
	1.06µm	524 27 090	524 27 160	524 27 180	524 27 200	524 27 208	524 27 223	524 27 505	524 27 525
	1.55µm	524 33 090	524 33 160	524 33 180	524 33 200	524 33 208	524 33 223	524 33 505	524 33 525
1480 l/mm	750 - 850 nm	524 28 090	524 28 160	524 28 180	524 28 200	524 28 208	524 28 223	524 28 505	524 28 525
	1.06µm	524 29 090	524 29 160	524 29 180	524 29 200	524 29 208	524 29 223	524 29 505	524 29 525
1740 l/mm	750 - 850 nm	524 20 090	524 20 160	524 20 180	524 20 200	524 20 208	524 20 223	524 20 505	524 20 525
	1.06µm	524 21 090	524 21 160	524 21 180	524 21 200	524 21 208	524 21 223	524 21 505	524 21 525
1800 l/mm	750 - 850 nm	524 24 090	524 24 160	524 24 180	524 24 200	524 24 208	524 24 223	524 24 505	524 24 525
	1.06µm	524 25 090	524 25 160	524 25 180	524 25 200	524 25 208	524 25 223	524 25 505	524 25 525
2000 l/mm	750 - 850 nm	524 23 090	524 23 160	524 23 180	524 23 200	524 23 208	524 23 223	524 23 505	524 23 525

Replica gratings for pulse compression

HORIBA Jobin Yvon has traditionally provided master gratings for pulse compression applications, to ensure the highest optical performance and damage threshold. Master gratings are manufactured by HJY in both small and large dimensions.

We have also developed a very accurate replication process for producing high-quality and lower cost pulse compression gratings for less-demanding applications. This specific replication process is available for small size pulse compression gratings up to 110x110 mm in dimension.

All replica gratings for laser pulse compression are gold coated.

FEATURES

- Absolute efficiency in TM polarization: better than 86%
- Diffracted wavefront quality: better than $\lambda/3$ at 800 nm or 1053 nm
- Coating: gold
- Four types of replica PCG gratings are available
- Three dimensions are standard

Delivered documentation with replica pulse compression gratings

- Absolute efficiency, measured in the grating center location
- Quality of the -1 order diffracted wavefront
- A certificate of conformity

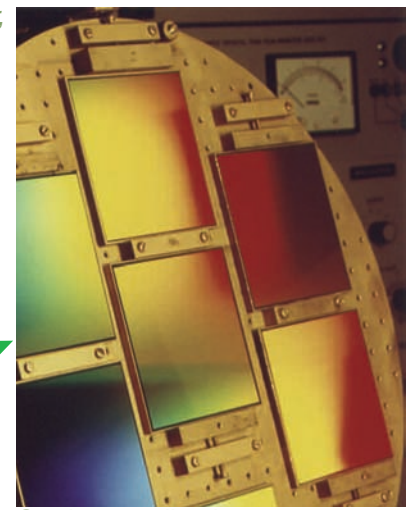
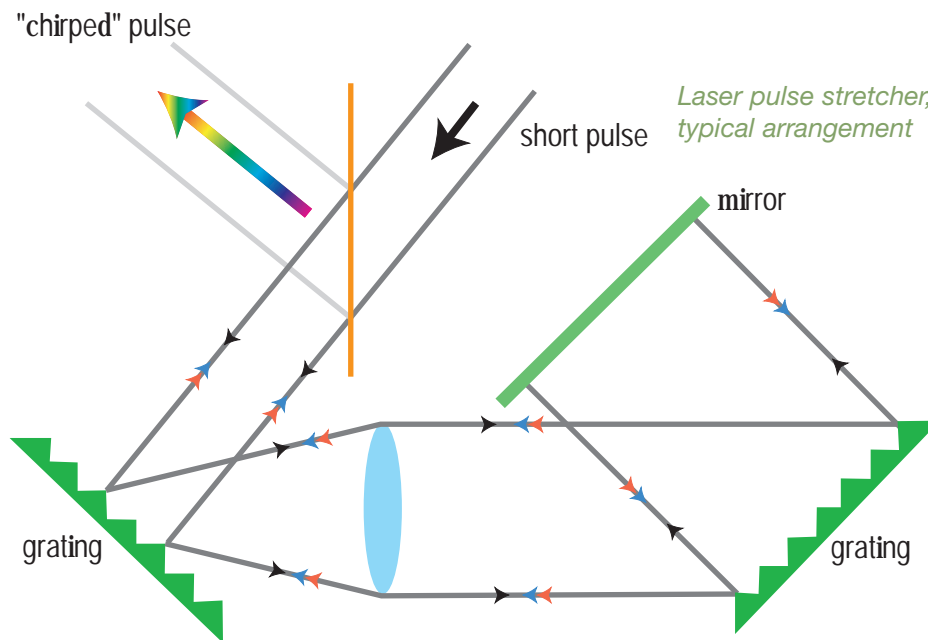

Gratings replication

	1200 l/mm		1480 l/mm	1740 l/mm
blank size (mm)	750 to 850 nm	1.55 μ m	750 to 850 nm	1.06 μ m
40x60x10	C524 26 090/T3	C524 33 090/T3	C524 28 090/T3	C524 21 090/T3
80x110x16	C524 26 160/T3	C524 33 160/T3	C524 28 160/T3	C524 21 160/T3
110x110x16	C524 26 180/T3	C524 33 180/T3	C524 28 180/T3	C524 21 180/T3

Gratings for laser pulse compression

Multi-layer dielectric gratings for pulse compression

The rapid development of intense sources for picosecond and femtosecond light pulses and in particular pulse compression techniques has prompted the need for new ultra-high performance, high damage threshold, diffraction gratings. HORIBA Jobin Yvon has been a leading supplier of gold coated pulse compression gratings since the development of the technique. Today HJY is developing unique MLD gratings¹ with higher damage threshold for very high power laser chirped pulse compression.

Traditional diffraction gratings for pulse compression applications are holographically recorded and coated with a gold metallic film. Metalized gratings have many useful features including diffraction efficiencies that can exceed 92% over a broad range of wavelengths. The groove profile as well as the optical properties of the metal coating determines the properties of the grating.

As far as laser induced damage threshold is concerned, gold coated gratings typically present the following values:

- 400 mJ/cm² on the grating surface for nanosecond pulses
 - 250 mJ/cm² on the grating surface for picosecond pulses
- and lower fluences for shorter pulses or shorter wavelengths.

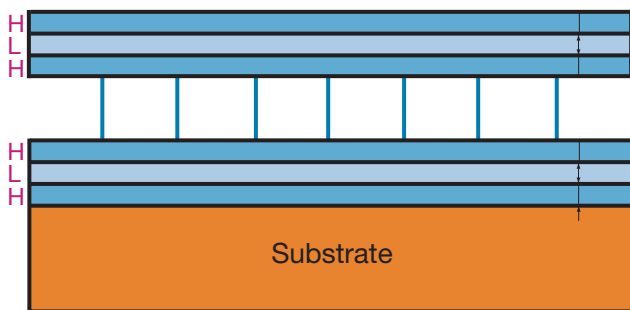

Typical multi layer dielectric mirror, L: low index layer, H: high index layer

For many years multi-layer dielectric (MLD) structures composed of alternating high and low index layers have been well known to be highly reflecting. At each interface between a low and high index pair about 4% of the light is reflected. Summing all of the light from

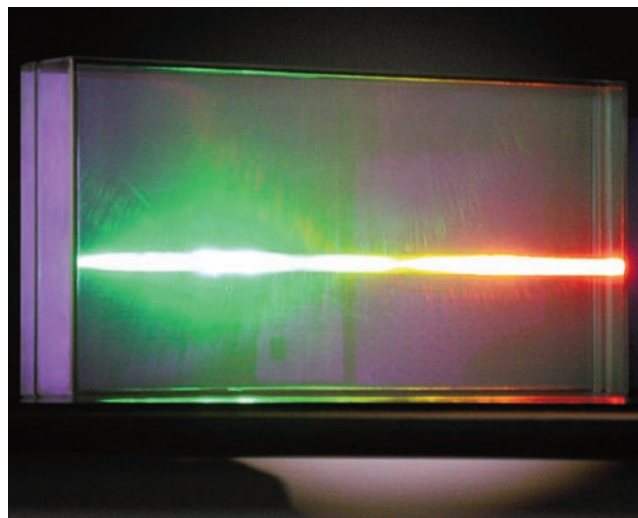

A 210 x 420 mm size Multi Layer Dielectric grating

the many layers gives an optic that can approach close to complete reflection. Since MLD structures are insulators they lack the conduction electrons that make metals good reflectors and thus can have intrinsically higher damage thresholds.

The manufacture of MLD gratings requires control of the stack of dielectric films, each of a predefined thickness, uniform coating of photoresist and very precise generation of the holographic pattern that defines the groove shape and distribution. The latent image in the photoresist is transferred permanently into the dielectric stack by ion etching.

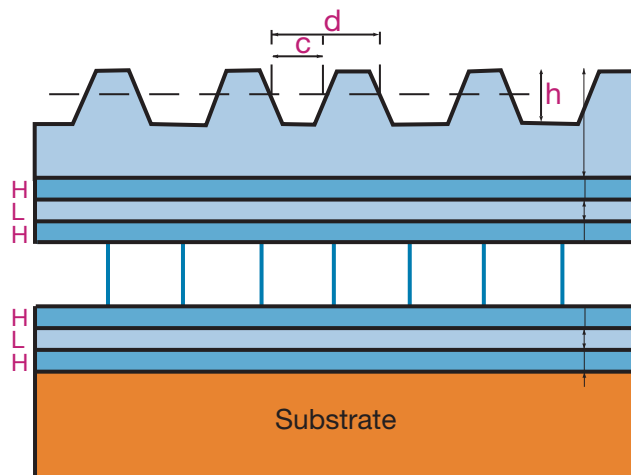

Multi layer dielectric grating, grooves engraved into the low index MLD upper layer

¹Sold in the US under license of Patent # 5,907,436

Current achievements

HJY is presently developing MLD gratings exclusively with 1740 l/mm groove density and to work at 1.053 micron.

We have produced a series of MLD gratings with following specifications:

- groove density: 1740 l/mm
- central wavelength: 1053 nm
- bandpass: 30 nm
- substrate dimensions:
 - 120x140x20 mm
 - 210x420x50 mm
 - 335x485x50 mm
 - 420x450x43 mm
- efficiency at 1053 nm: higher than 92%
- wavefront quality: $\lambda/4$

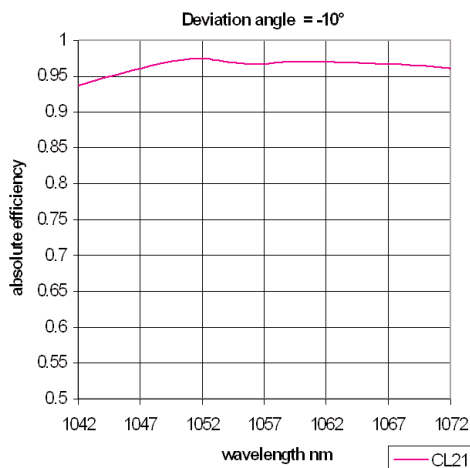

1740 l/mm, optimized 1053 nm, MLD grating bandpass

This curve is for reference only and is not meant to be a specification

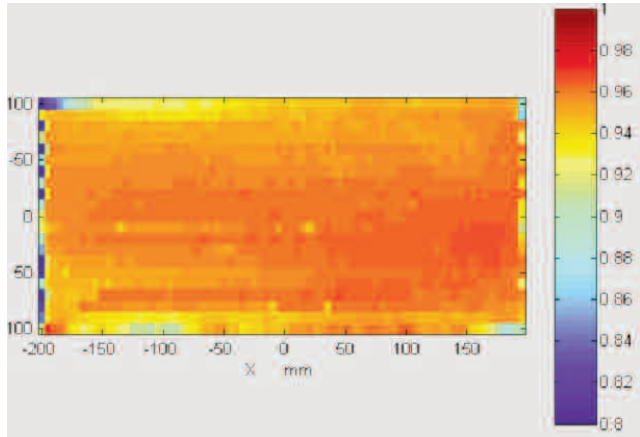

Example of 210x420 mm, 1740 l/mm, MLD grating efficiency map (average efficiency is 94% at 1.053 micron in this case)

NOTE: our damage threshold conversions

Influence of the incident beam angle: if 1.7 J/cm² fluence on the grating surface has been measured for 10 picosecond pulses, it may correspond to different beam fluences.

For example:

for 61° incidence, 1.7 J/cm² fluence on the grating surface, will be equal to 3.5 J/cm² beam fluence (cos61° = 0.48);

and for 72° incidence, 1.7 J/cm² fluence on the grating surface will be equal to 5.5 J/cm² beam fluence (cos 72°=0.31).

Consequently, designs with higher incidence angle on the grating at the output of the compressor are expected to be favorable for damage threshold.

blank size (nm)	groove density (l/mm)	central wavelength (nm)	reference
165x220x30	1740	1053	524 40 223
210x420x50	1740	1053	524 40 525
335x485x50	1740	1053	524 40 820
420x450x43	1740	1053	524 40 920

Note concerning 800 nm MLD pulse compression gratings:

To compress titanium sapphire laser pulses to extremely short pulses such as 100 fs or less, the compressor gratings have to support very large wavelength bandpass typically 100 nm or more. The development of multi-layer dielectric coatings for

this application has not yet led yet to any commercially viable solution. For these applications, we propose gold coated, pulse compression gratings that work around 800 nm, with large bandpass.

Transmission gratings for high energy lasers

Transmission gratings for high energy lasers

The Laser Megajoule (LMJ) gratings

The Laser Megajoule (LMJ) is a high energy laser facility under construction in Bordeaux for the French nuclear research agency (Commissariat à l’Energie Atomique, CEA). At completion, 240 pulsed laser beams will be focused on a 2 mm target, delivering 2 MJ and producing the high density, pressure and temperature conditions where nuclear fusion triggers.

An original feature of the LMJ is the use of large diffractive optic components, where the only comparable system in the world (the American National Ignition Facility at Lawrence Livermore Laboratories in California) uses classical dioptric components.

Thanks to a close cooperation between CEA and HJY scientists, the feasibility of these unique components (400x400 mm focusing gratings) was confirmed and production started in 2000 for the demonstration prototype which confirmed the high performance of the design.

The profile figure presents the SEM profile of the gratings produced at HJY: the groove depth is 2 times the period which was a real challenge. The uniformity over the 420x470 mm surface is also a technological achievement.

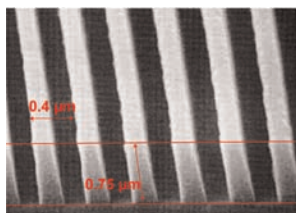

SEM groove profile of 2500 l/mm transmission grating

The efficiency map of a 1ω LMJ transmission grating demonstrates the large scale ion-etching uniformity

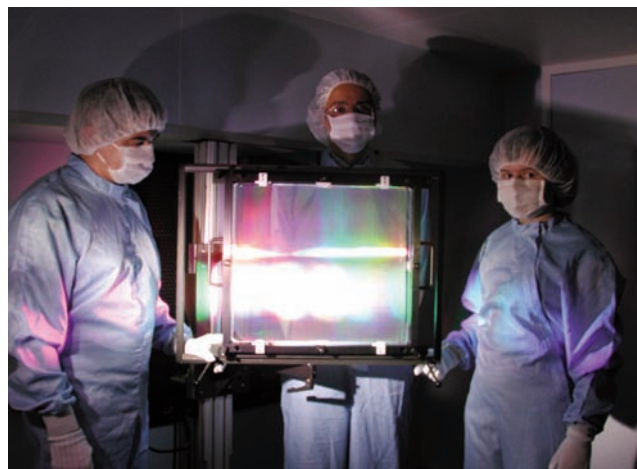
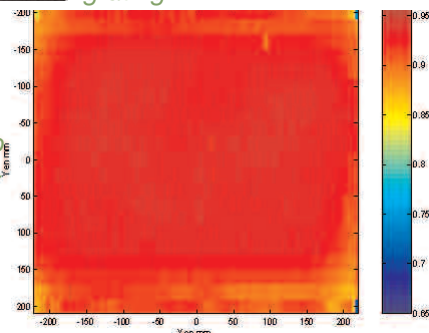

Specifications of the transmission gratings for high energy lasers

To produce the LMJ-type transmission gratings, we produce first a holographic mask, then we transfer the mask modulation directly into the fused silica substrate. So the grating is made only of fused silica (without any photoresist on epoxy layer). As a result the laser-induced damage threshold is as high as a fused silica plate.

We are producing two types of transmission gratings for high energy lasers:

□ gratings 1ω: gratings with straight and equidistant lines, 800 l/mm, optimized for 1.053 μm, 92 to 94% average efficiency on TM polarization.

□ gratings 3ω: focusing grating with curved and non-equidistant lines, 2400 l/mm optimized for 351 nm, 90 to 92% average efficiency on TM polarization. This focusing grating acts as a stigmatic focusing lens.

Measured damage threshold =
25 J/cm² at 1.053 μm for ns pulse
12 J/cm² at 351 nm for ns pulse

Gratings for astronomy and space experiments

Holographic master and replica gratings

HJY expertise in gratings for space experiments

HJY has been producing gratings for space experiments since 1968. The first ruled gratings were produced for the French space experiment D₂A in 1970.

HJY has produced some of the most technically-challenging space-flight gratings ever designed, applications ranging from off-plane X-ray gratings to toroidal VLS gratings for the VUV and transmission deep groove gratings for the IR range.

For example, HJY produced the four gratings for NASA/JHU FUSE spectrograph. The gratings are 5800 gr/mm, aberration corrected, holographically ruled on 300x300 mm, aspherical light weight ceramic.

A prototype FUSE spectrograph grating being removed from a vacuum tank in a clean room at HORIBA Jobin Yvon. The FUSE gratings are approximately a foot square with 5300-5800 lines per millimeter

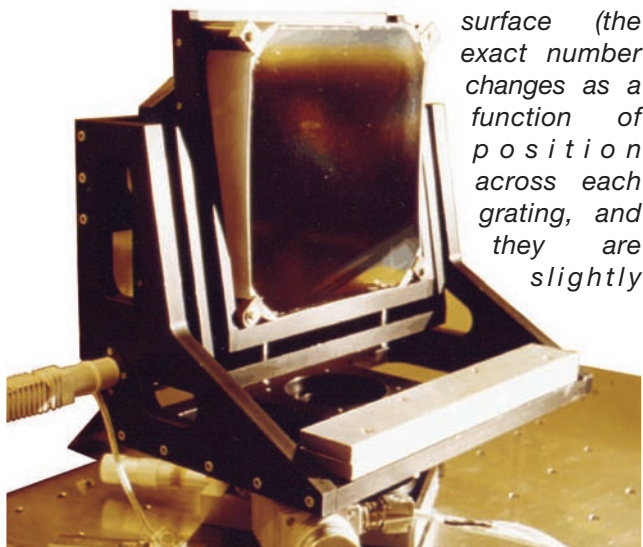

etched onto the surface (the exact number changes as a function of position across each grating, and they are slightly

curved). These etchings are what disperse far-UV light into a spectrum for analysis, and provide the high spectral resolution of the spectrograph.

FUSE spectrograph with four aberration corrected holographic gratings, 5800 l/mm, 300x300 mm

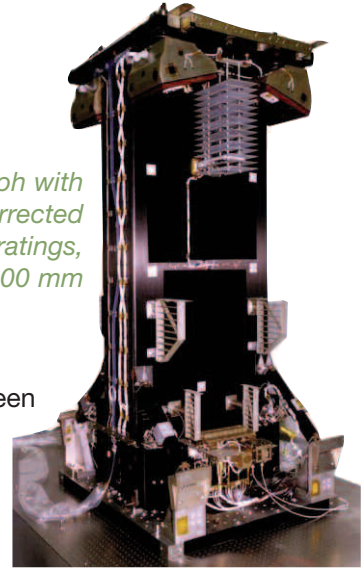

HJY has also often been selected by NASA and ESA for their most demanding missions. A very reduced list includes:

SOHO SUMER	France + Germany
SOHO UVCS	USA
STIS (Hubble telescope)	USA
GALEX	USA + France
ROSETTA Alice	USA + France
COS (Hubble telescope)	USA
SOFIS	Japan
SPICAM/ MARS Express	France
OMI - EOS	Netherlands
LYMAN FUSE	USA + France
ROALEX	USA
GOMOS (Hubble telescope)	France + Belgium
MERIS/ENVISAT	France
UVS MARS	Japan
GOME	Italy
WEASAT	China

Recently we produced gratings for missions such as EVE (NASA/LASP) and SSULI (NRL).

HJY receives NASA award

HJY received the NASA award "Commitment to Excellence in Technology Achievement" for its grating technology contribution for its specific support on the COS project.

Gratings for astronomy and space experiments



“In recognition of your holographic gratings for the COS instrument that will enable a new generation of scientific exploration for the Hubble Space Telescope [...] and every person who looks to the sky in wonder [...] **the gratings were delivered above the specification, on time and within cost,**” said Prof. Jim Green.

Production and test facilities

HORIBA Jobin Yvon’s underground grating labs provide the necessary environmental stability required to mechanically rule and holographically record the highest-specification diffraction gratings.

Our ruling engines, lasers, collimators, optical components, and chemical processing equipment are housed in clean rooms throughout the facility.

Coating and chemical operations are performed in our own processing laboratory. The lab is geared to accommodate all the company’s replication and deposition requirements with equipment including fully-automatic high-vacuum evaporation systems.

All equipment involved in handling and processing of master gratings are operated in different cleanrooms down to class 100.

Space qualification

Space qualification was achieved for HJY’s ruled and holographic gratings (masters and replicas) by the French CNES as early as 1971 and 1972, when we produced gratings for the D2B satellite.

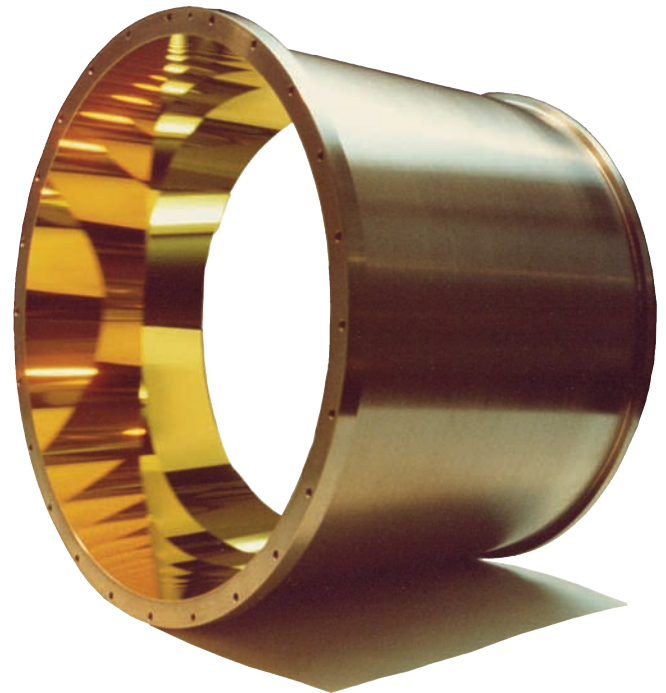

Wolter mirror (manufactured by replication)



*LDEF (Long Duration Exposure Facility)
NASA experiment*

HORIBA Jobin Yvon ruled and holographic gratings were aboard the LDEF satellite, which stayed in space for 69 months before retrieval by the Space Shuttle. Extended space vacuum experiments (34000 orbits, with thermal cycling each orbit) demonstrated that HJY’s ruled and holographic gratings (masters and replicas) maintained wavefront quality, stray light levels, and absolute efficiency under harsh space conditions.

Bulk transmission gratings for astronomy

Holographic ion-etched ruled transmission gratings

High-efficiency IR transmission gratings (grisms) engraved into fused silica substrates

In many astronomy applications, grisms (transmission gratings patterned on a prism) are widely used for in-line dispersion of an infrared spectrum.

In the infrared, classical replicated grisms present many limitations. The epoxy layer, necessary for replication, absorbs infrared light. In addition, this epoxy layer compromises the integrity of the grism when used at low temperatures.

To address these issues, HJY has designed and manufactured transmission gratings which are holographically patterned and etched directly into IR fused silica substrates.

Three grating types were developed, for wavelengths ranging from 1 micron to 2.4 microns. The diffraction efficiency reaches 60% to 70% in natural light.

Engraved directly into fused silica, these gratings can survive very low temperature conditions and vacuum environments.

High-efficiency UV transmission gratings (grisms) engraved into CaF₂ substrates

Through our expertise in ion etching, HJY has developed a process which allows us to produce optimized groove patterns in CaF₂. A master grating is ruled in a gold layer deposited on top of the grating substrate, and then the groove profile is transferred by ion etching directly into the substrate itself. The result is a monolithic sawtooth-profile grating which can withstand extreme temperatures and environmental conditions.

A saw-tooth profile transmission grating, ion-etched directly into a CaF₂ substrate for use at 140 nm in second order, has been successfully produced for the GALEX experiments.



Rosetta mission: fly by of Mars



Example of a high efficiency IR transmission grating (GRISM) directly etched into an IR grade fused silica substrate

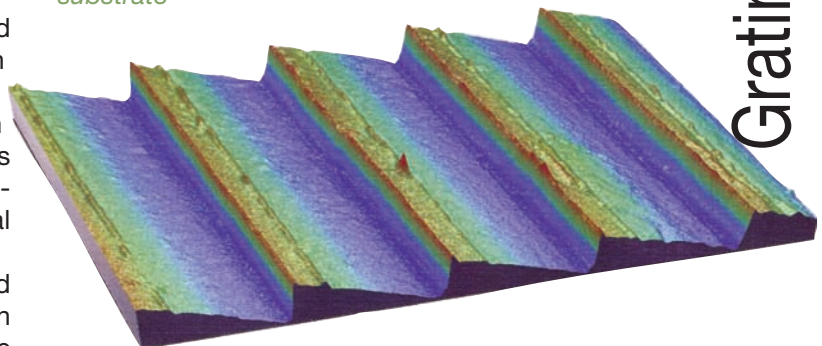

Example of an ion-etched ruled grating profile (into CaF₂ material) made for the GALEX experiment

Gratings for astronomy and space experiments

Ion-etched gratings for vacuum UV and soft X-ray applications

Holographic ion-etched lamellar master gratings for synchrotron and soft X-ray applications.

HORIBA Jobin Yvon's holographic ion-etched lamellar gratings exhibit ultra-low stray light levels, making them ideal for synchrotron and soft X-ray applications. These gratings are fully compatible with the latest synchrotron systems, as they are fully engraved in the substrate material and can therefore withstand high thermal loads.

The holographic ion etching manufacturing process is compatible with most high-grade polished substrate materials, including:

- Silicon,
- Fused Silica,
- CVD silicon carbide.

HORIBA Jobin Yvon produces holographic ion-etched gratings on plano, spherical, and toroidal substrates. We can tailor the groove distribution (i.e. constant spacing, aberration correction, or VLS) to optimize gratings for the most demanding applications.

Typical specifications

- Material: Silicon
- Slope error: $\leq 0.7 \mu\text{rad}$
- Roughness: $< 0.5 \text{ nm}$
- Roll off: 5 mm
- Land to groove ratio: 0.5 to 0.6
- Land to groove ratio tolerance: $\pm 10\%$
- Groove depth: 9 to 200 nm
- Groove depth tolerance: $\pm 10\%$
- Coating: Pt or Au or Ni

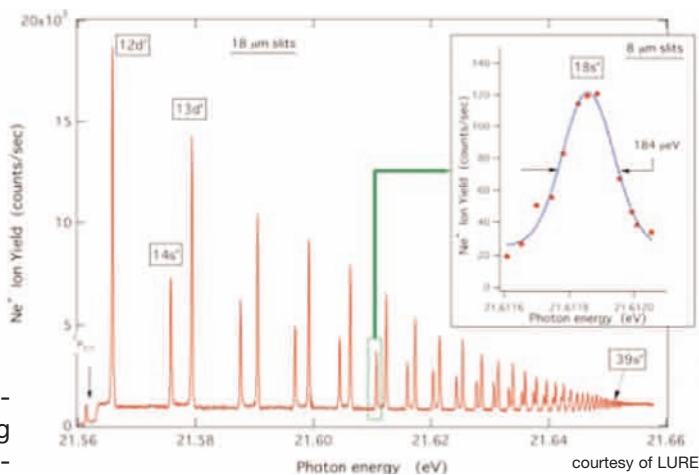

Constant groove density:

The groove density of the grating is defined by the interference of two plane wavefronts, resulting in a uniform and constant groove spacing along the grating length.

Aberration-corrected groove density:

The groove spacing along the grating length is non-uniform, resulting from the interference of two spherical wavefronts. The non-constant groove density enables the correction of certain aberrations in the optical system.

VLS groove density:

The Variable Line Spacing grating displays a groove-density variation that is defined by a polynomial law. This type of grating is commonly used in synchrotron beamline designs to correct for the defocusing of a grating monochromator. HORIBA Jobin Yvon and the synchrotron community together have developed software tools to define holographic recording geometries for VLS gratings, which allows us to produce gratings according to an arbitrary polynomial VLS law.

Examples of holographic ion-etched lamellar master gratings

Plane constant groove density grating

reference	blank dimension	useful arera	grooves density	blank	spectral range
549 00 xxx	30x100x20	20x90	1200	Si	300-950 eV / 1.3-4.5 nm
553 00 xxx	30x100x20	20x90	600	Si	170-600 eV / 2-7 nm

Spherical constant groove density grating

- Radius of curvature: 17 800 mm
- Radius of curvature tolerance: ±1 000 mm

reference	blank dimension	useful arera	grooves density	blank	spectral range
549 00 133S	30x100x20	20x90	1200	Si	300-950 eV / 1.3-4.5 nm
549 00 134S	30x100x20	20x90	600	Si	170-600 eV / 2-7 nm
549 00 135S	30x100x20	20x90	300	Si	100-300 eV / 4-12 nm

Plane variable line spaced grating

- VLS law: $N(x) = N_0 + N_1x + N_2x^2$

reference	shape	blank size (mm)	useful arera (mm)	polynomial coefficients	blank	spectral range
549 00 014S	plane	35x155x30	30x150	$N_0 = 500 \text{ gr/mm}$ $N_1 = 0.555 \text{ gr/mm}^2$ $N_2 = 4.61 \cdot 10^{-4} \text{ gr/mm}^3$	Si	180-700 eV / 1.7-7 nm

If you are interested by a specific grating for your application, please contact your HORIBA Jobin Yvon representative.

He will be glad to review your specific requirements.

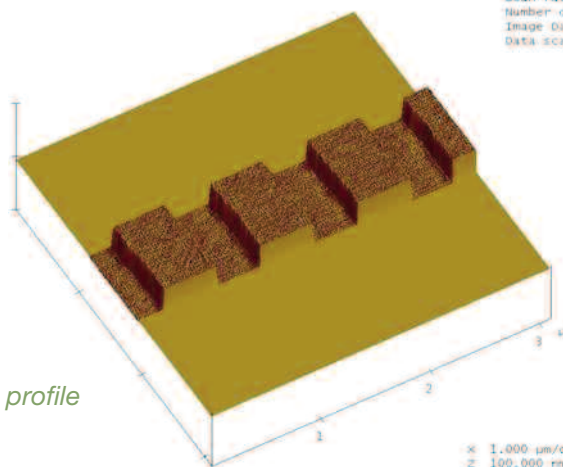

3D AFM grating profile

Toroidal ion-etched holographic master gratings for VUV applications

Single focusing/dispersing optic for cost-effective VUV optical systems

The holographic recording process – a non-contact manufacturing technique – allows for the patterning of gratings on aspheric surfaces. HORIBA Jobin Yvon has developed manufacturing methods to define, produce, and test diffraction gratings on toroidal substrates. Toroidal gratings combine the off-axis focusing properties of a toroidal reflector and the dispersive properties of a grating into a single optic, allowing for simplified, high-throughput monochromator and spectrograph designs.

Toroidal diffraction gratings are recorded with a varying groove density along the grating length, which is defined and optimized for correcting aberrations in a particular instrument. This non-uniform groove density is holographically generated by interfering two spherical wavefronts on a photoresist layer deposited on the toroidal surface. The grating pattern is then transferred directly into the substrate bulk using an ion etching process; this technique (used in the semiconductor industry) creates a lamellar groove structure that minimizes unwanted harmonic contamination.

Our toroidal substrates are polished and tested in our own optics fabrication laboratory, allowing us to maintain strict quality control.

HORIBA Jobin Yvon toroidal diffraction gratings are a cost-effective solution for designing high throughput vacuum UV instruments.

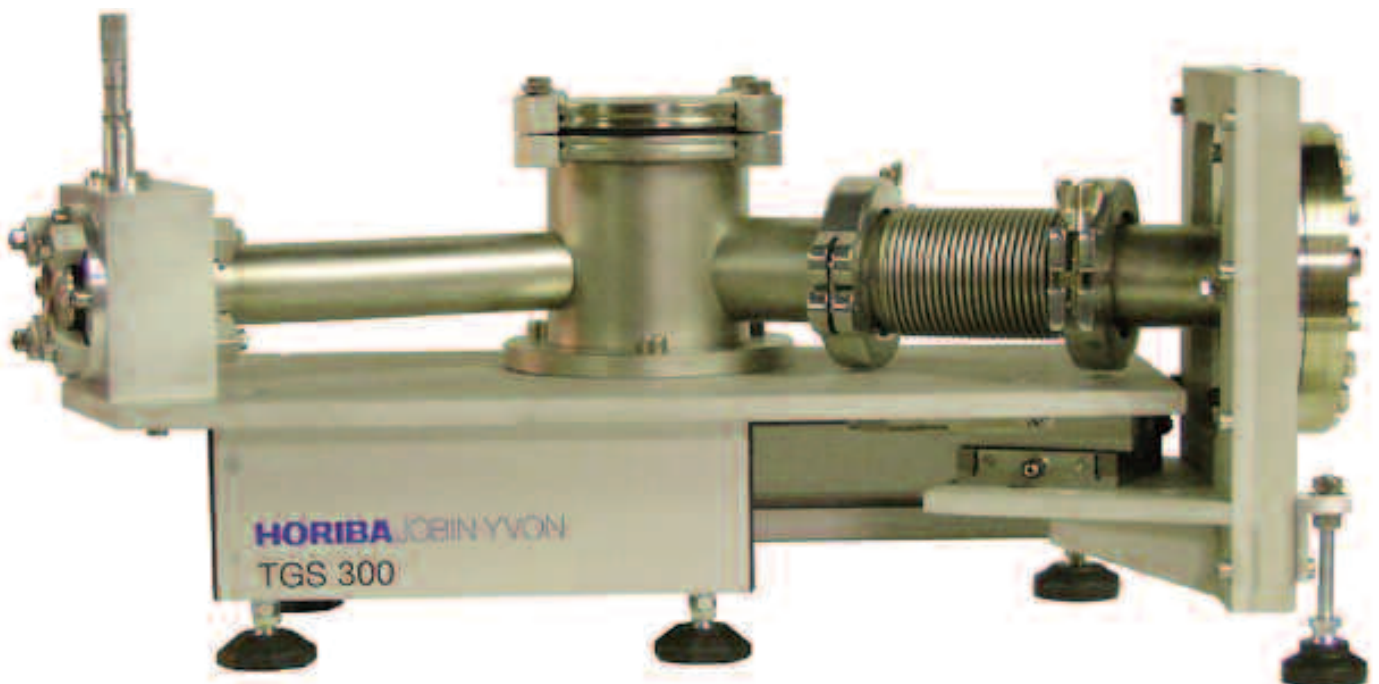

Toroidal grating spectrograph

Toroidal grating monochromator

Ion Etched Gratings

deviation (deg)	spectral range		groove density (l/mm)	blank dim (mm)	useful area (mm)	ℓ_A (mm)	ℓ_B (mm)	reference
	nm	eV						
150	8-32	39-155	1800	45x90x16	40x85	1146	1927	540 00 600
150	32-128	10-39	450	45x90x16	40x85	1146	1927	540 00 610
146	12.5-52.5	23-100	950	30x110x30	25x105	1000	1168	540 00 800
146	50-200	6-25	250	30x110x30	25x105	1000	1168	540 00 810
142	10-50	25-124	550	31x31x15	27x27	319.9	319.5	540 00 900
142	15-150	8-82	550	31x31x15	27x27	319.9	319.5	540 00 910
142	50-300	4-25	275	31x31x15	27x27	319.9	319.5	540 00 920

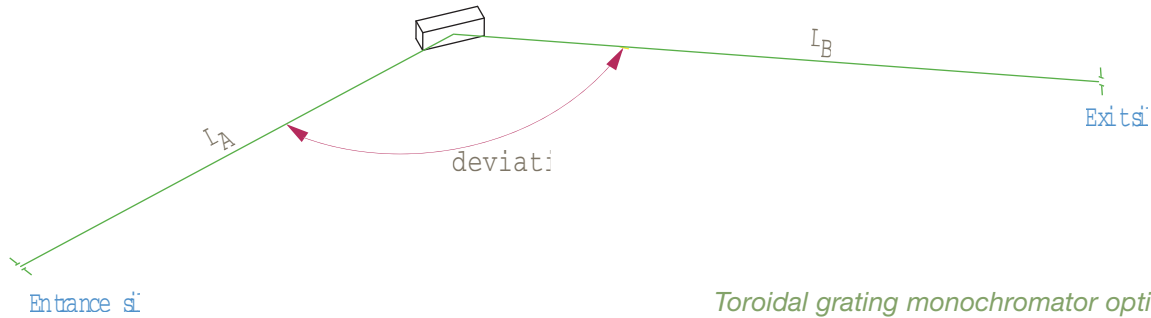

Toroidal grating spectrograph

Ion Etched Gratings

deviation (deg)	spectral range		groove density (l/mm)	blank dim (mm)	useful area (mm)	ℓ_A (mm)	α (deg)	ℓ_H (mm)	β_H (deg)	reference
	nm	eV								
140	9.5-32	39-130	2105	12x34x10	8x22	292.1	-71.78	306.0	86.54	541 00 220
140	10-110	11-124	450	12x34x10	8x22	292.1	-70.56	306.0	87.85	541 00 200
140	15.5-170	7-80	290	12x34x10	8x22	292.1	-70.56	306.0	87.85	541 00 210

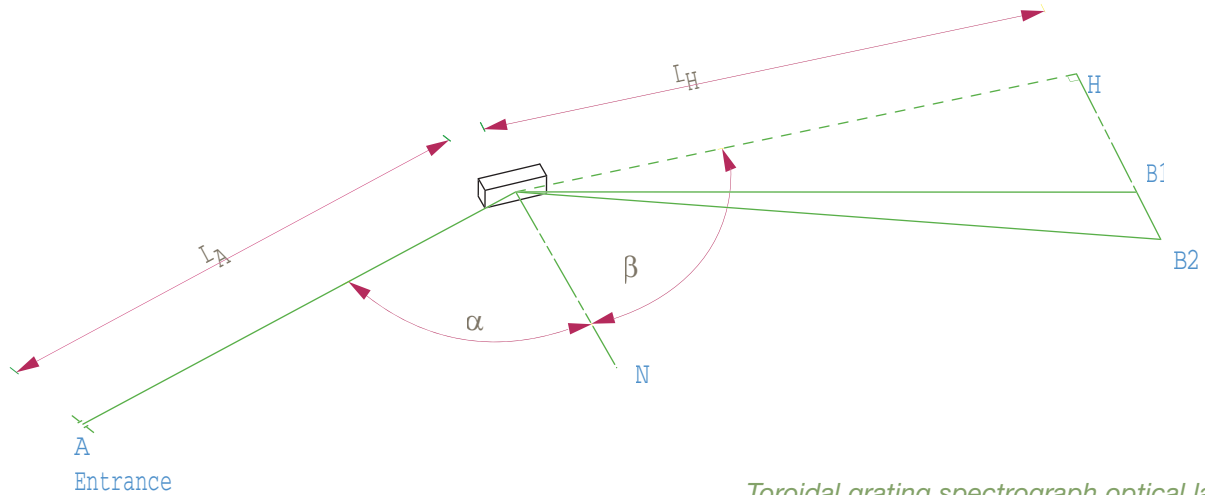

Variable Groove Depth (VGD) master gratings for XUV application

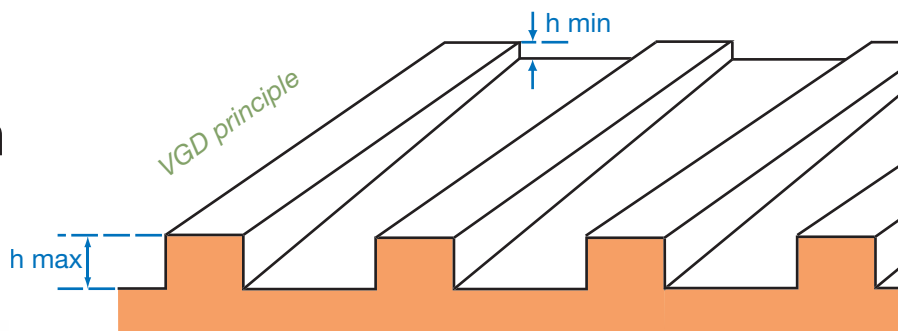

HORIBA Jobin Yvon VGD grating technology is compatible with:

- Silicon and fused silica grating substrates
- Holographic recording processes
- Constant, aberration corrected, and VLS groove distributions
- Ion etching processes
- XUV reflective coatings

One VGD grating gives you the efficiency of several classical gratings

Variable Groove Depth (VGD) gratings from HORIBA Jobin Yvon exhibit a continuously-varying groove depth across the grating width, allowing for continuous adjustment of the grating blaze wavelength with a simple lateral translation. When such blaze adjustments are combined with rotational scanning and a narrow beam, our VGD gratings provide a unique opportunity to perform continuous on-blaze scans and to minimize harmonic contamination over a wide spectral range.

Our VGD grating technology is compatible with the most-recent synchrotron beamline designs that provide a mm size synchrotron beam onto the grating. Replacing a classical or multi-track gratings with a HORIBA Jobin Yvon VGD will open new experimental opportunities, with optimized flux performance over the entire beamline spectral range.

material:	non-oriented silicon crystal
micro-roughness:	less than 0.5 nm RMS
slope error:	0.7 μ rad RMS
land to groove ratio:	0.55 within $\pm 15\%$
coatings:	Au, Pt or Ni

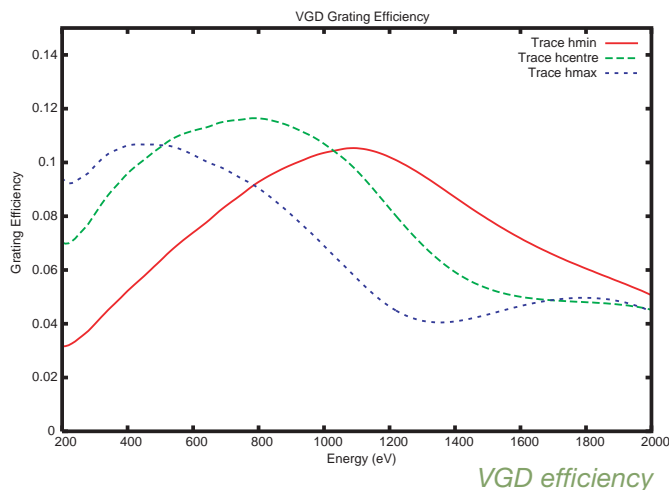

Example of VGD gratings

blank size	useful arera	grooves density	Nominal depth variation over 25 mm		
			h min (nm)	h centre (nm)	h max (nm)
40x100x30	35x90	1800	4.5	10	15.5
40x100x30	35x90	600	18	35	52
40x100x30	35x90	300	42.5	80	117.5

High-grade mirrors for VUV and XUV applications

The technical specifications placed on synchrotron radiation diffraction gratings such as excellent shape control, ultra low roughness, etc. are similar to the one placed on the mirrors that are installed on a synchrotron beam-line.

In order to control the diffraction-grating substrate quality HORIBA Jobin Yvon developed a dedicated polishing facility.

These polishing capabilities are used internally to supply state-of-the-art grating substrates to our recording grating laboratory and also high-quality VUV Soft X-ray mirrors for your applications.

HORIBA Jobin Yvon places considerable emphasis on the testing of components at every stage of the manufacturing process. Thus HORIBA Jobin Yvon can analyze errors and apply appropriate corrective action to the subsequent manufacturing stages. Slope Error is measured using interferometry and is cross-calibrated using long trace profilometry (LTP). Microroughness is measured using a Nomarski microscope during the preliminary polishing. The final quantitative microroughness measurements are made using a MicroMap interferential microscope to ensure compliance with specifications.

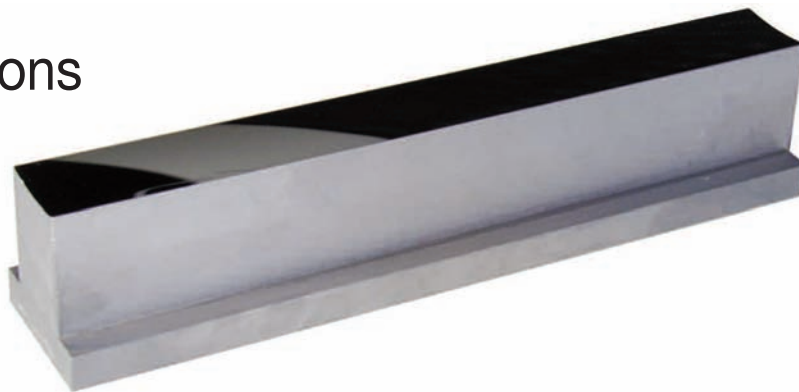

HORIBA Jobin Yvon capabilities include:

- Material: Silicon, SiC CVD, Fused Silica, Zerodur
- Shape: Plane, Spherical, Cylindrical, Toroidal
- Surface shape: down to 0.5 μ rad (0.1 arcsec)
- Roughness: down to 0.2 nm
- XUV reflective coating: Pt, Au, C, Ni

In addition to the below presented standard toroidal and cylindrical mirrors, HORIBA Jobin Yvon can manufacture custom plane, spherical, cylindrical and toroidal mirrors. Please contact your HORIBA Jobin Yvon representative for radius availability, manufacturability, price and delivery.

Example of toroidal mirror:

reference	shape	blank size (mm)	useful area (mm)	radius of curvature (mm)	blank	roughness (nm)	slope error (μ rad)
545 70 038S	toroidal	50x250x50	20x230	R ₁ = 57 300 R ₂ = 93.1	Si	0.5	5
545 70 060S	toroidal	40x280x40	30x270	R ₁ = 328 360 R ₂ = 261.77	Si	0.5	5

Example of cylindrical mirror:

reference	shape	blank size (mm)	useful area (mm)	radius of curvature (mm)	blank	roughness (nm)	slope error (μ rad)
545 70 039S	cylindrical	60x300x60	30x280	R = 698	Si	0.5	5

Holographic plane gratings

HORIBA Jobin Yvon has produced a wide range of holographic master gratings from which we manufacture high precision replicas.

Our replica gratings retain the advantages of our master holographic gratings:

- Perfect periodicity, plus excellent micro-roughness of the surface eliminates ghosts and enhances stray light rejection
- Minimal groove errors provide very high resolution
- Availability of very high groove densities: up to 5670 lines/mm

Dimensions of our high-precision replica gratings typically range from 25x25 mm up to 120x140 mm. For customers in need of larger dimensions, HJY can record a custom-made holographic grating master specifically for replication.

Typical efficiency performances of holographic plane gratings

The efficiency of a sinusoidal holographic grating is determined by the ratio of the wavelength and groove spacing λ/σ . In general:

- if $\lambda/\sigma \geq 0.8$, efficiency will approach 85% in TM polarized light, and 60% in unpolarized light
- when $0.2 \leq \lambda/\sigma \leq 0.8$, efficiency for unpolarized light is between 35% and 50%.
- when $\lambda/\sigma < 0.2$ maximum efficiency in unpolarized light will be approximately 35% for the UV, visible, and near IR region of the spectrum.

Holographic gratings usually exhibit a very broad spectral bandwidth.

Typical holographic plane grating efficiencies

Efficiency curves

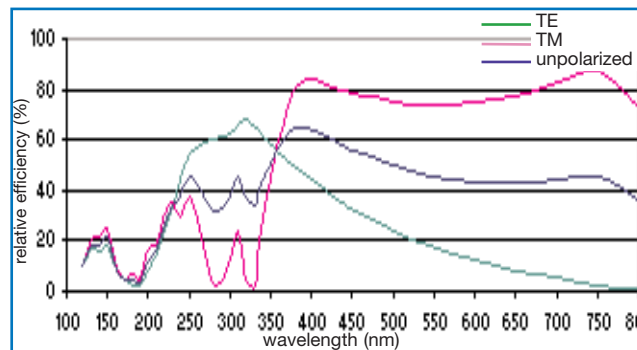

520 13, 2400 l/mm, 170-500 nm

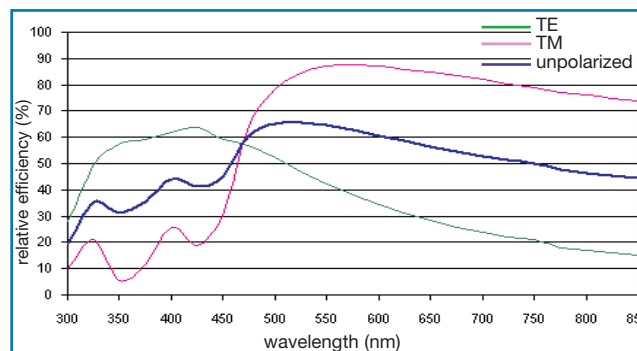

520 19, 1800 l/mm, 450-850 nm

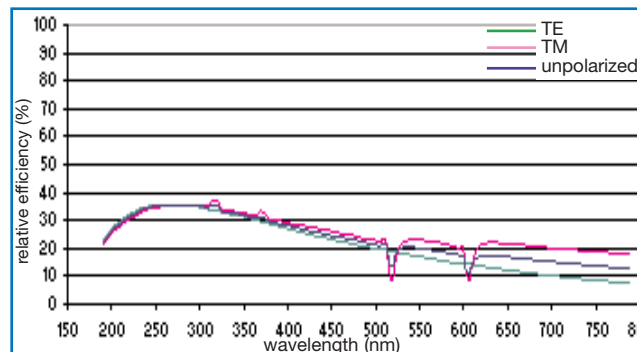

520 25, 1200 l/mm, 190-700 nm

NOTE:

These efficiency curves are absolute theoretical efficiencies, calculated using rigorous electromagnetic theory, taking into account the true groove profiles of manufactured gratings measured with an atomic force microscope (AFM). These curves are for reference only and do not indicate grating specifications.

List of standard holographic plane gratings

l/mm	spectral range (nm)	reference	available max replica dimension
5670	100-300	520 01	
4960	100-350	520 02	
4320	170-400	520 04	
4320	100-300	520 05	
3600	150-450	520 07	
3000	250-550	520 09	
2400	300-650	520 12	
2400	170-500	520 13	
2400	100-300	520 14	
2000	450-750	520 15	
2000	190-700	520 16	
2000	150-450	520 17	
2000	100-300	520 18	
1800	450-850	520 19	
1800	190-700	520 20	
1800	150-450	520 21	
1800	100-300	520 22	
1200	400-1300	520 24	
1200	190-700	520 25	
1200	150-450	520 26	
1200	100-300	520 27	
900	1250-1750	520 95	
600	400-1300	520 29	
600	150-450	520 30	
150	250-800	520 32	
150	400-1200	520 33	

Ruled area: extends to within a 2-4 mm border around the grating edge

Standard substrate material is Pyrex; on request, substrates including fused silica, Zerodur, ULE, metals, or other materials can be considered.

Standard coating is aluminium. On request, AlMgF2, gold or platinum are also available for an additional cost.

Grating size table

size code	blank size
020	25x25x8
050	34x34x10
070	30x40x10
080	44x44x10
090	40x60x10
330	50x50x6
110	58x58x10
120	68x68x9
140	76x76x16
150	90x90x16
160	80x110x16
180	110x110x16
190	110x135x25
200	120x140x20

To place an order, please use the grating reference number and add the size code;

Example:

For 2000 lines/mm and the spectral range 150-450 nm, use the grating reference 520 17.

For the size 58x58x10 mm, use the size code 110.

Therefore, the full part number of this grating is 520 17 110.

Blazed holographic plane gratings

Blazed holographic plane gratings

HORIBA Jobin Yvon has produced a wide range of blazed holographic master gratings from which we manufacture high precision replicas.

Our replica gratings retain the advantages of our master holographic gratings:

- Perfect periodicity, plus excellent micro-roughness of the surface eliminates ghosts and enhances stray light rejection
- Minimal groove errors provide very high resolution

In addition, owing to their ion-etched, sawtooth groove profiles, these gratings offer higher peak efficiency than standard holographic gratings.

List of blazed holographic plane gratings

Ruled area: extends to within a 2-4 mm border around the grating edge

Standard substrate material is Pyrex; on request, substrates including fused silica, Zerodur, ULE, metals, or other materials can be considered.

Standard coating is aluminium. On request, AlMgF2, gold or platinum are also available for an additional cost.

groove density (l/mm)	spectral range (nm)	blaze (nm)	max replica dimension (mm)	reference
2400	190-700	250	120X140X20	530 13
2400	240-750	330	120X140X20	530 11
2400	300-800	400	110X135X25	530 15
1800	190-700	250	110X110X16	530 20
1800	250-900	400	110X110X16	530 18
1800	450-900	500	110X110X16	530 19
1200	190-1200	250	110X110X16	530 25
1200	240-1200	330	110X110X16	530 22
1200	360-1250	500	110X110X16	530 24
1200	400-1300	630	110X110X16	530 27
1200	500-1500	750	110X110X16	530 28
1200	600-1600	900	90X90X16	530 50
950	700-1700	900	110X110X16	530 60
900	700-1700	850	110X110X16	530 66
600	360-1250	500	90X90X16	530 29
600	700-1750	1000	110X110X16	530 34

Typical blazed holographic plane grating efficiencies

Efficiency curves

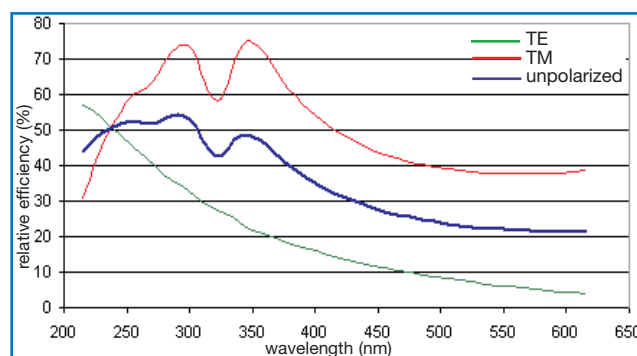

530 13, 2400 l/mm, 190-700 nm

NOTE:

These efficiency curves are absolute theoretical efficiencies, calculated using rigorous electromagnetic theory, taking into account the true groove profiles of manufactured gratings measured with an atomic force microscope (AFM).

These curves are for reference only and do not indicate grating specifications.

Grating size table

size code	blank size
020	25x25x8
050	34x34x10
070	30x40x10
080	44x44x10
090	40x60x10
330	50x50x6
110	58x58x10
120	68x68x9
140	76x76x16
150	90x90x16
160	80x110x16
180	110x110x16
190	110x135x25
200	120x140x20

Holographic concave gratings-Type I

Type I Holographic Concave Gratings are recorded on spherical substrates, with equidistant and parallel grooves. Their geometric optical properties are the same as classically ruled gratings and are interchangeable with them.

When used in a spectrograph, Type I Holographic Concave Gratings are traditionally disposed on the Rowland circle (i.e., the circle defined by the grating center and the tangential radius of curvature of the grating). The point-source entrance slit is also located

on this circle, and the grating forms a spectrum on this same circle, virtually free of defocus and primary coma. Spherical aberration is generally reasonable, yet astigmatism is very significant. As a result of this astigmatism, many Rowland spectrographs offer high resolution but are limited in their light-collection efficiency.

List of Type I holographic concave gratings

groove density (l/mm)	spectral range (nm)	concave-radius (mm)	blank dimensions (mm)	reference
1200	200-800	112.14	32x32	521 12 350
100	4500-6000	112.14	32x32	531 26 350
150	500-700	139.19	Ø70	521 30 390
150	500-700	139.19	Ø90	521 30 430
83	400-800	173.9	Ø53	521 25 380
2400	200-400	201.4	58x58	521 05 060
2400	200-400	201.4	30x30	521 06 040
1200	200-600	201.4	58x58	521 12 060
1200	340-800	201.4	30x30	521 12 040
600	400-700	201.4	30x30	521 15 040
600	400-700	201.4	58x58	521 15 060
2700	120-400	498.1	Ø50.8	521 22 360
3600	100-300	499.7	30x30	521 02 100
3600	150-450	499.7	Ø63.5	521 03 101
2400	100-300	499.7	30x30	521 05 100
2400	200-400	499.7	30x30	521 06 100
4800	118-166	499.8	58x58	521 24 370
2700	120-165	600	Ø50	531 27 400
2400	165-590	600	Ø50	531 28 400
2400	170-600	752	Ø63.5	531 26 110
1200	60-150	995.4	Ø114.3	521 10 130
3000	130-520	998.8	Ø63.5	521 23 160
2550	120-415	998.8	Ø63.5	521 17 160
2400	100-300	998.8	Ø63.5	521 05 160
2160	70-200	998.8	Ø63.5	521 20 160
2160	170-450	998.8	Ø63.5	521 19 160
1080	170-800	998.8	Ø63.5	531 21 160
1080	337-815	998.8	Ø50.8	531 21 420
1666.7	165-670	1200	Ø50	521 29 410
3600	160-450	1500	Ø63.5	521 03 180
2400	160-450	1500	Ø63.5	521 05 180
2400	200-650	1500	Ø63.5	521 06 180
1200	170-700	1500	Ø100	521 11 190
600	90-270	1999.5	Ø100	521 13 220
600	100-300	2217.6	Ø63.5	521 14 240

Ruled area: extends to within a 2-4 mm border around the grating edge

Standard substrate material is Pyrex; on request, substrates including fused silica, Zerodur, ULE, metals, or other materials can be considered.

Standard coating is aluminum. On request, AlMgF2, gold or platinum are also available for an additional cost.

Flat field and imaging gratings- Type IV

Flat field and imaging gratings - Type IV

Type IV aberration corrected flat field & imaging gratings are designed to focus a spectrum onto a plane surface, making them ideal for use with linear or 2-D array detectors.

These gratings are produced with grooves that are neither equispaced nor parallel, and are computer optimized to form near-perfect images of the entrance slit on the detector plane.

Owing to their large optical numerical aperture and correction from aberrations, these Type IV aberration corrected flat field & imaging gratings provide much better light collection efficiency and signal to noise ratio than traditional Type I Rowland circle concave gratings.

The illustration shows a “super corrected grating” imaging two independent sources onto two independent linear arrays. Spectrum 1 is a “sample spectrum” from slit 1 and spectrum 2 a reference spectrum from slit 2. These “slits” could be fiber optic inputs.

When an area detector such as a CCD is utilized, it is often possible to focus multiple sources onto the entrance slit and independently evaluate the spectrum from each source. These “Imaging Gratings” are nearly free from astigmatism, and therefore only one fixed optical element is required to construct an imaging spectrograph.

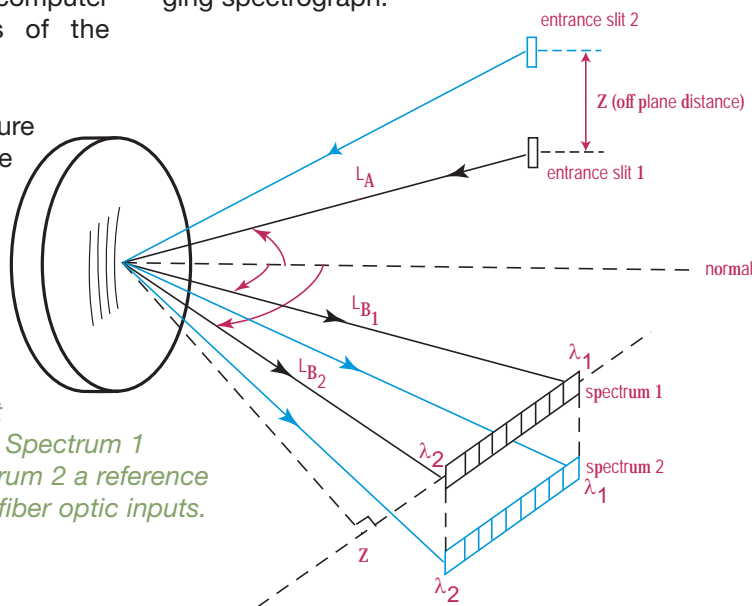

List of Type IV flat field & imaging gratings

reference number	dispersion (nm/mm)	wavelength range (nm)	spectrum length (mm)	LA (mm)	blank dim. (mm)	F / #	grooves per mm	note
523 00 080	4	300-400	25	210	∅ 70	3.2	1200	a
523 00 010	8	200-400	25	210	∅ 70	3.2	600	a
523 00 020	16	400-800	25	210	∅ 70	3.2	300	a.b
523 00 030	24	200-800	25	210	∅ 70	3.2	200	a.b
523 00 070	24	300-900	25	210	∅ 70	3.2	200	a
523 00 040	36	300-1170	25	210	∅ 70	3.2	138	a
523 00 050	40	200-1200	25	210	∅ 70	3.2	120	a
523 00 060	48	200-1400	25	210	∅ 70	3.2	100	a
523 01 020	14	190-455	18.8	190	∅ 70	2.8	360	a.c
523 01 030	24	190-820	25	190	∅ 70	2.8	200	a.c
523 01 070	24	300-820	21.6	190	∅ 70	2.8	200	a.c
523 01 040	37.8	285-1232	25	190	∅ 70	2.8	133	a.c
523 01 090	37.8	500-1232	19.3	190	∅ 70	2.8	133	a.c
523 01 060	76	600-2500	25	190	∅ 70	2.8	65	a.c

Note: a_n : these gratings are interchangeable (same geometry of use)
 b : these gratings are blazed by ion etching (higher efficiency)
 c : these gratings are imaging gratings
 d : these gratings are ion-etched, laminar profile (suppression of the 2nd order)

reference number	dispersion (nm/mm)	wavelength range (nm)	spectrum length (mm)	LA (mm)	blank dim. (mm)	F / #	groove density (l/mm)	note
523 00 420	1.0	250-450	203	257	Ø50	5.1	1800	
523 00 410	1.1	440-520	70	326	Ø50	6.7	2000	
523 00 430	1.4	100-400	210.4	238	Ø30	7.9	1340	
523 00 440	1.6	170-500	211.1	238	Ø30	7.9	1200	
523 00 730	4.6	395-705	68	231	Ø100	2.4	793	
533 00 110	5	200-360	32	223	Ø55	4.4	807	b
543 00 180	5	4160-4180	4	258	Ø70	3.9	376	d
533 00 450	7.1	200-350	21.2	113	44x44	2.3	900	
523 00 540	7.9	340-660	40.6	201	Ø90	2.3	600	
523 00 510	8.1	330-660	40.4	210	Ø108	2	540	
533 00 550	8.4	340-750	49	148	Ø38	4	800	b
543 00 170	9	175-400	25.1	153	40x40	4	580	d

reference number	dispersion (nm/mm)	wavelength range (nm)	spectrum length (mm)	LA (mm)	blank dim. (mm)	F / #	groove density (l/mm)	note
523 00 560	10	380-720	33.7	107	Ø50	2	900	
533 00 570	10	370-760	37.1	99	Ø32	3	950	b
533 00 890	15.5	340-800	29.6	58	25x25	2.2	785	b
523 00 210	15.6	800-1000	12.8	105	46x46	2.2	595	
533 00 580	16	340-690	24	145	Ø44	3.3	430	b
533 00 100	15.8	340-830	31	163	52x52	3.3	372	b
533 00 720	16	380-780	25	138	Ø50	2.8	457	b
533 00 670	23	340-800	19.7	89	30x30	2.8	440	b
533 00 130	24	190-800	25.4	210	Ø40	5.3	200	b
533 00 710	24	190-800	25	138	Ø50	2.8	298	b
543 00 150	25.1	1600-2200	23.9	148	40x40	3.7	267	d
523 03 120	25.5	190-800	24.6	90	Ø48	2	340	
523 00 470	27	400-950	20	85	Ø48	1.8	217	

reference number	dispersion (nm/mm)	wavelength range (nm)	spectrum length (mm)	LA (mm)	blank dim. (mm)	F / #	groove density (l/mm)	note
523 00 460	29	320-710	13.4	100	Ø50	2	310	
523 00 480	30	200-800	20	85	Ø48	1.8	200	
533 00 700	32	300-1100	25	138	Ø50	2.8	227	b
533 00 610	40	330-780	11.3	120	34x34	3.5	250	b
523 00 840	53	190-870	12.6	94	44x44	2	185	
523 00 630	67	380-720	5	40.4	32x32	1.5	320	
523 00 810	67	380-820	6.6	93	Ø54	1.8	143	
523 00 150	67.4	1600-2200	8.9	101	Ø54	2	130	
523 00 820	68	750-1180	6.4	93	Ø54	1.8	143	
523 00 530	106	350-1050	6.6	143	Ø42	3.4	65	

Monochromator gratings - Type IV

Monochromator gratings - Type IV

Using Type IV aberration-corrected monochromator Gratings, a single concave grating disperses, collimates and refocuses the light from the entrance slit onto the exit slit. Wavelength scanning is obtained through a simple rotation of the grating.

The groove spacing of these gratings is computer-optimized to produce high quality images with a mini-

imum of astigmatism and coma, even at large numerical aperture.

Compared with Czerny-Turner monochromators (equipped with one plane grating, one collimating mirror and one focusing mirror) Type IV aberration corrected monochromator gratings provide much better light collection efficiency and signal-to-noise ratio.

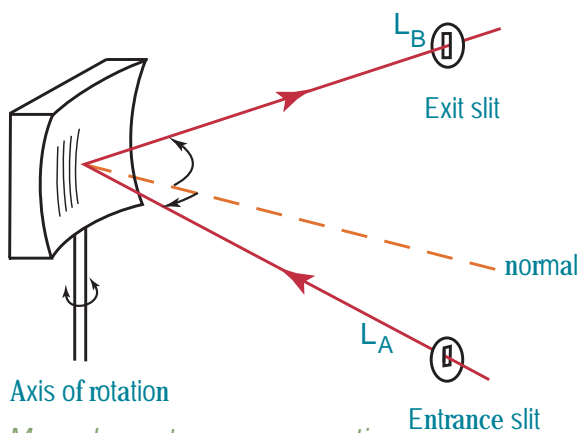

Axis of rotation

Monochromator concave grating

LA: distance between the grating and the entrance slit

LB: distance between the grating and the exit slit

D: deviation angle

F/#: optical aperture

Example monochromator model H10-61
 Optical aperture: F/3
 Focal length: 100 mm
 ACH grating: aberration corrected holographic grating

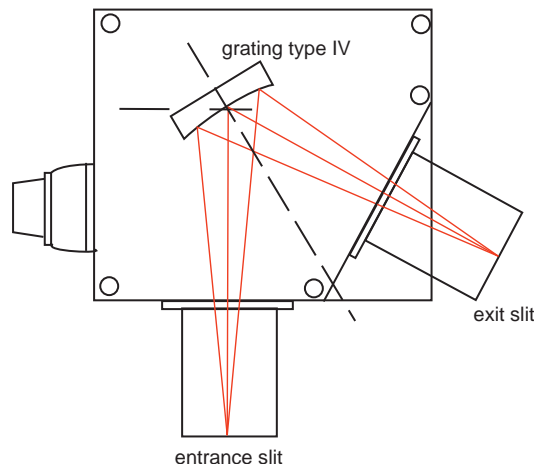

Custom, aberration corrected, concave gratings

In addition to the standard lists of Type IV flat field and monochromator gratings, HJY currently produces specific aberration-corrected concave gratings to maximize performance for a given application.

In that case, using proprietary ray-tracing software, we optimize performance: resolution, throughput and signal to noise ratio. We need following data from our customers:

- spectral range
- configuration of use: monochromator or spectrograph
- numeral aperture (F number) or size of grating

- maximum overall dimension or maximum focal length
- desired dispersion
- desired resolution
- entrance slit width and height or source geometry
- minimum deviation: in general deviation has to be minimum to improve correction of astigmatism, so indicate possible minimum deviation when overall dimensions of source, sample chamber and detector are taken into consideration.
- at exit: if monochromator, exit slit width and height, and if flat field, length of detector, height and width of pixel.

List of Type IV aberration-corrected monochromator gratings

Gratings are replicated from our extensive inventory of high-quality master gratings. New gratings are frequently added; please inquire for your specific needs.

When blaze wavelength is indicated (blaze column), it means that this grating has been blazed by ion etching and presents high efficiency
 Ruled area: extends to within a 2-4 mm border around the grating edge.

spectral range (nm)	dispersion (nm/mm)	groove density (l/mm)	deviation D (deg)	ℓA	ℓB	blank dim.	F	blaze	order	reference
190-800	8	1200	61.6	100	94.0	32x32	3	250	1	532 00 110
250-800	8	1200	61.6	100	94.0	32x32	3	350	1	532 00 120
300-1200	12	800	61.6	100	94.0	32x32	3		1	522 00 130
300-800	8	1200	61.6	100	94.0	32x32	3	450	1	532 00 130
400-1600	16	600	61.6	100	94.0	32x32	3		1	522 00 140
800-3200	32	300	61.6	100	94.0	32x32	3		1	522 00 150
190-900	4	1200	61.6	200	187.9	40x45	4.2	250	1	532 00 210
200-1000	4	1200	61.6	200	187.9	40x45	4.2	350	1	532 00 220
300-1100	4	1200	61.6	200	187.9	40x45	4.2	450	1	532 00 230
350-1200	6	800	61.6	200	187.9	40x45	4.2		1	522 00 260
400-1600	8	600	61.6	200	187.9	40x45	4.2		1	522 00 230
400-2100	10	450	61.6	200	187.9	40x45	4.2		1	522 00 270
800-3200	16	300	61.6	200	187.9	40x45	4.2		1	522 00 240
100-300	4	1200	64	200	187.9	40x45	4.2		1	522 00 250
175-520	0.5	1500	61.2	1232	1000	42x42	26		1	522 00 470
200-800	2.2	1484	46.4	335	303	∅150	2.2		1	522 00 450
200-800	7	950	40	136	151	∅32	4.2	250	1	532 00 520
250-750	2.2	1500	56	300	320	58x58	4.6		1	522 00 460
350-800	2.2	1484	46.4	335	303	∅150	2.2		1	522 00 490
380-740	9	1800	38	201	184	90x90	2		1	522 00 510
400-1100	9	670	27	150	150	50x50	3		1	522 00 540
400-1200	3.3	1000	46.4	335	303	∅150	2.2		1	522 00 480
480-800	0.5	2000	3	1000	1000	110x110	8		1	522 00 410
1000-2400	9.6	500	41.3	191	184	∅70	2.5		1	522 00 600
1100-2500	8	600	30	210	160	∅110	1.9		1	522 00 530
1200-2400	3	570	38	201	184	90x90	2		1	522 00 500
5000-10000	64	100	38	108	113	60x70	1.6		1	542 00 160

Ruled plane gratings

Ruled plane gratings

HORIBA Jobin Yvon has produced a wide range of ruled master gratings from which we manufacture high precision replicas.

Dimensions of our high-precision replica gratings typically range from 25x25 mm up to 120x140 mm.

On page 35, we indicate the blaze angle (α) which is given by the formula:
 $2a \sin \alpha = k \lambda_B$, where a is the groove spacing, k is the diffraction order (usually $k=1$) and λ_B is the blaze wavelength (in Littrow configuration).

Typical efficiency performance of ruled plane gratings

Typical ruled plane grating efficiencies

Efficiency curves

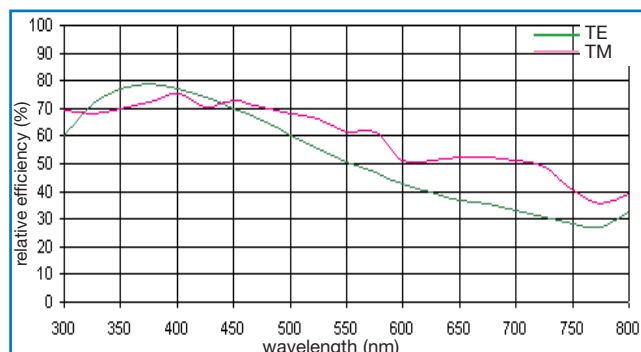

510 12; 600 l/mm; blaze 400 nm

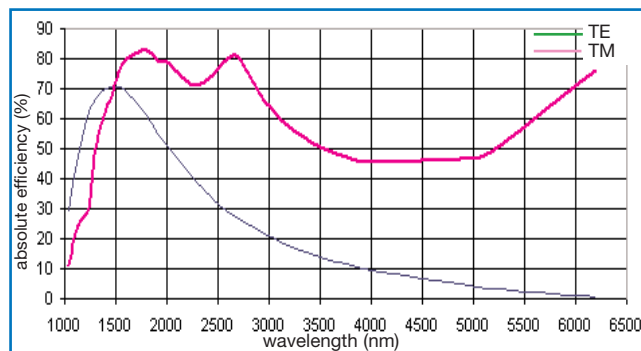

510 21; 300 l/mm; blaze 2 μ m

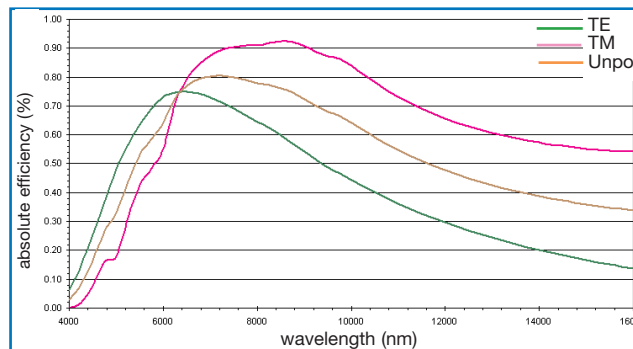

510 37; 75 l/mm; 5-16 μ m

NOTE:

These efficiency curves are absolute theoretical efficiencies, calculated using rigorous electromagnetic theory, taking into account the true groove profiles of manufactured gratings measured with an atomic force microscope (AFM).
 These curves are for reference only and do not indicate grating specifications.

Custom master ruled gratings for CO₂ lasers

HORIBA Jobin Yvon offers master ruled plane gratings optimized at 10.6 micron for CO₂ lasers.

- ruling density is 150 l/mm
- coating: gold
- substrate material: stainless steel
- substrate dimension: 25 mm diameter on 25x25 mm
- absolute efficiency: higher than 95% for TM polarization over 9 to 11 μ m wavelength range

Ruled plane gratings are replicated from our extensive inventory of high-quality master gratings. New gratings are frequently added; please inquire for your specific needs.

Grating size table

size code	blank size
020	25x25x8
050	34x34x10
070	30x40x10
080	44x44x10
090	40x60x10
330	50x50x6
110	58x58x10
120	68x68x9
140	76x76x16
150	90x90x16
160	80x110x16
180	110x110x16
190	110x135x25
200	120x140x20

Ruled area: extends to within a 2-4 mm border around the grating edge

Standard substrate material is Pyrex; on request, substrates including fused silica, Zerodur, ULE, metals, or other materials can be considered.

Standard coating is aluminium. On request, AlMgF2, gold or platinum are also available for an additional cost.

groove density (l/mm)	blaze wavelength	blaze angle	max replica dimension (mm)	reference
1800	330 nm	17°27'	90x90x16	510 01
1800	500 nm	26°45'	90x90x16	510 02
1800	630 nm	34°32'	68x68x9	510 03
1200	250 nm	8°38'	58x58x10	510 04
1200	330 nm	11°25'	58x58x10	510 05
1200	400 nm	13°53'	58x58x10	510 06
1200	500 nm	17°27'	58x58x10	510 07
1200	630 nm	22°12'	58x58x10	510 08
1200	750 nm	26°45'	58x58x10	510 09
1200	1 µm	36°52'	58x58x10	510 10
900	350 nm	9°00'	90x90x16	510 91
900	550 nm	14°30'	58x58x10	510 93
900	1.5 µm	42°27'	76x76x16	510 97
600	300 nm	5°10'	110x110x16	510 11
600	400 nm	6°54'	110x135x25	510 12
600	500 nm	8°38'	120x140x20	510 13
600	750 nm	13°00'	90x90x16	510 14
600	1 µm	17°27'	120x140x20	510 15
600	1.5 µm	26°45'	110x110x16	510 16
600	2 µm	36°52'	110x110x16	510 17
300	250 nm	2°09'	110x110x16	510 50
300	500 nm	4°18'	120x140x20	510 18
300	600 nm	5°10'	120x140x20	510 19
300	1 µm	8°38'	110x110x16	510 20
300	2 µm	17°27'	110x110x16	510 21
300	3 µm	26°45'	120x140x20	510 22
300	4 µm	36°52'	120x140x20	510 23
150	500 nm	2°09'	110x110x16	510 49
150	1.2 µm	5°10'	110x110x16	510 24
150	2 µm	8°38'	110x110x16	510 25
150	4 µm	17°27'	120x140x20	510 26
150	5 µm	22°01'	120x140x20	510 27
150	6 µm	26°45'	120x140x20	510 28
150	8 µm	36°52'	110x110x16	510 29
120	2.5 µm	8°39'	110x110x16	510 30
120	5 µm	17°27'	120x140x20	510 31
120	7.5 µm	26°45'	120x140x20	510 32
100	450 nm	1°17'	110x110x16	510 48
100	3 µm	8°38'	110x110x16	510 33
100	6 µm	17°27'	120x140x20	510 34
100	9 µm	26°45'	120x140x20	510 35
75	4 µm	8°38'	110x110x16	510 36
75	8 µm	17°27'	110x110x16	510 37
75	12 µm	26°45'	110x110x16	510 38
60	10 µm	17°27'	90x90x16	510 39
60	15 µm	26°45'	110x110x16	510 40
50	12 µm	17°27'	110x110x16	510 42
50	18 µm	26°45'	110x110x16	510 43
50	24 µm	36°52'	110x110x16	510 44
40	22.5 µm	26°45'	90x90x16	510 45
30	30 µm	26°45'	90x90x16	510 46
20	45 µm	26°45'	76x76x16	510 47

Dye laser gratings

HORIBA Jobin Yvon has developed two types of gratings for dye lasers: L series (Littrow configuration) and G series (grazing incidence configuration). These holographic gratings are optimized for efficiency when used with TM radiation.

Standard gratings are aluminum coated. Gold coating is offered upon request, to improve efficiency above 600 nm.

L series (Littrow)

blank dimensions				reference
per mm	(λ) (nm)	(nm/mrad)	at max. (%)	
3600	280-380	22	69	524 01
3000	300-550	28	69	524 02
2400	450-650	30	82	524 03
2000	480-650	43	69	524 04

size code	blank size
010	dia 25x10
020	25x25x8
060	dia 50x10
070	30x40x10
090	40x60x10

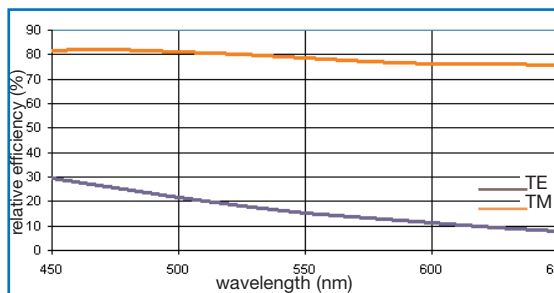

524 03 Littrow

G series (grazing)

Our grazing incidence gratings have been optimized for very high resolution when used with very large angles.

blank dimension mm		
grooves mm	spectral range (λ)	reference
3600	330-500	524 11

size code	blank size
260	17x58x11
270	30x110x16
280	35x140x20

Efficiency curves are very flat, and specific blaze wavelengths are not specified. Efficiency vs incidence angle is available upon request.

Ruled area: extends to within a 2-4 mm border around the grating edge.

Standard substrate material is Pyrex; on request, substrates including fused silica, Zerodur, ULE, metals, or other materials can be considered. Standard coating is aluminum. On request, AlMgF2, gold or platinum are also available for an additional cost.

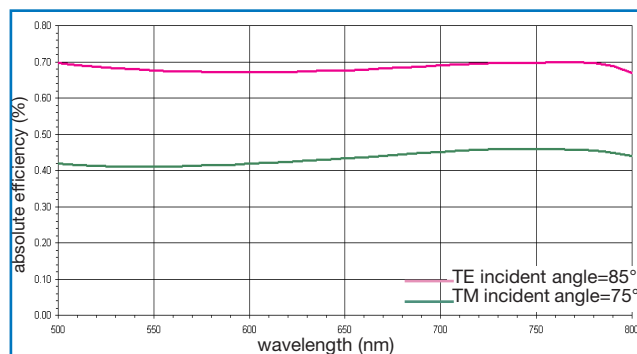

524 12 - 2400 l/mm, coating Al, polarization TM

NOTE:

These efficiency curves are absolute theoretical efficiencies, calculated using rigorous electromagnetic theory, taking into account the true groove profiles of

manufactured gratings measured with an atomic force microscope (AFM). These curves are for reference only and do not indicate grating specifications.

Dye laser gratings

Coatings

Gratings and mirrors:

Depositions of reflective metallic coatings are performed with cryogenic evaporation in our production laboratory warranting grating performance. Gratings are provided with a standard aluminum coating. Other standard coatings (to improve reflectivity in certain spectral ranges) may also be requested.

We suggest:

- Above 6000 Å : IR gold
- Between 1500 Å to 6000 Å: Al
- Between 1150 Å and 1650 Å : Al+MgF₂
- Below 1000 Å : UV gold or platinum or nickel

Additional coatings for specific VUV and soft X-ray applications, such as carbon or SiC are available on request for your specific applications.

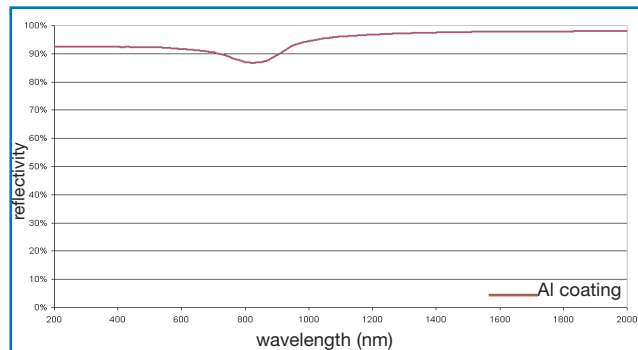

Reflectivity for Al coating
incident angle = 0°, unpolarized light

VUV & soft X-ray gratings:

Reflectivity depends on the light beam incidence angle. HJY can help you review reflectivity and efficiency values according to your incidence angle and wavelength range.

Ordering information

Al + MgF ₂ (optimized 1216-1610 Å)	50 000 001
IR Gold	50 000 003
UV Gold	50 000 004
UV Platinum	50 000 005

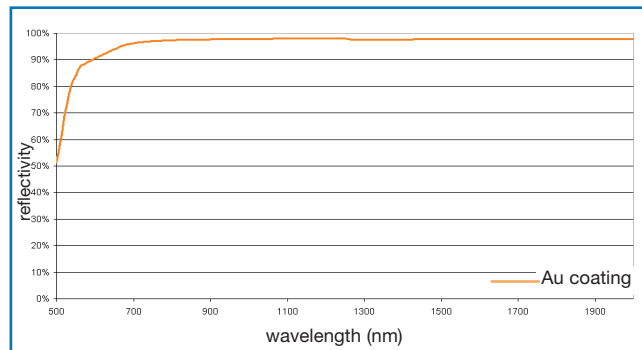

Reflectivity for Au coating
incident angle = 0°, unpolarized light

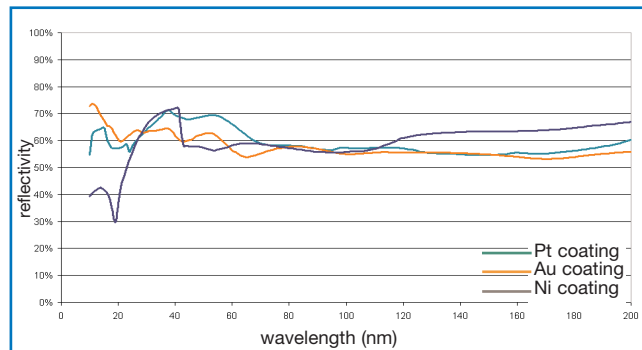

Example of reflectivity for different metallic coating
incident angle = 80°, unpolarized light

NOTE:

These reflectivity curves are for reference only and do not represent coating specifications.

HORIBA Jobin Yvon divisions

HORIBA Jobin Yvon: dedicated to scientific innovation in optical spectroscopy and other techniques since 1819

MOLECULAR AND MICROANALYSIS

FLUORESCENCE

Analytical and modular research spectrofluorometers for steady-state, TCSPC and frequency domain lifetime. For biotechnology to nanotechnology.

RAMAN ANALYSIS

Laboratory, research and process instruments from UV to IR. Microscope, remote probe and custom sampling options.

X-RAY FLUORESCENCE

Non-destructive EDXRF elemental analysis to less than 10 µm spot size. Micro/macro sampling, and mapped imaging. WEEE/RoHS compliance testing.

EMERGING BUSINESS

FORENSICS

Crime scene and laboratory light sources. Fingerprint and palm print identification systems. Image enhancement software.

ELLIPSOMETRY

Benchtop and in-situ spectroscopic and laser ellipsometers. Non-destructive characterisation of thin films for thickness and optical properties.

THIN FILM PROCESS CONTROL

Thin film processing and plasma diagnosis using imaging laser interferometry, optical emission spectroscopy, ellipsometry and polarimetry.

MARKETS AND INDUSTRIES

Academia

Biotechnology

Chemicals

Coatings

Environmental

Food & Beverage

Forensic Science

Geology & Exploration

Instrumentation

Life Sciences

Semiconductors

Pharmaceuticals

Petroleum

Optoelectronics

Nanotechnology

Medical

Material Sciences

and product lines

HORIBA Jobin Yvon: dedicated to scientific innovation in optical spectroscopy and other techniques since 1819

MARKETS AND INDUSTRIES

Academia

Biotechnology

Chemicals

Coatings

Environmental

Food & Beverage

Forensic Science

Geology & Exploration

Instrumentation

Life Sciences

Semiconductors

Pharmaceuticals

Petroleum

Optoelectronics

Nanotechnology

Medical

Material Sciences

OPTICAL COMPONENTS

OPTICAL SPECTROSCOPY

Monochromators, spectrographs, array and single-channel detectors, light sources and sample accessories.

DETECTORS

CCD and other detectors for spectroscopy and imaging applications. Contract manufacture for OEM.

OEM SPECTROMETERS AND GRATINGS

Gratings, monochromators, spectrographs including detectors, acquisition electronics and light sources for industrial applications.

CUSTOM GRATINGS AND VUV BEAMLINES

Gratings for high power lasers, space flight experiments and VUV instruments. Synchrotron VUV chambers, mirrors and beamlines.

ELEMENTAL ANALYSIS

ATOMIC EMISSION SPECTROSCOPY

ICP, spark and glow discharge optical emission spectrometers. Elemental analysers for C, S, H, N & O. Sulphur in petroleum analysis.

PARTICLE SIZE ANALYSERS

Particle characterization equipment covering the range from 3 nm to 3 mm.

FAX FORM

For more information or custom grating / mirror quotations, please complete the corresponding request info on our web site: www.jobinyvon.com or send this completed form by fax.

The personal details that we use to provide or promote our products and services (for example your name and telephone number), will NOT be passed to ANY organization beyond the HORIBA Group, its Subsidiary or Associate Companies, Agents or Distributors to be used for marketing purposes.

Your Contact Details:

Last Name:	First Name:
Title:	Organization:
Dept:	Address:
State/Province:
Country:	Postal Code:
(USA please include Zip)	
Telephone:	E-Mail:
Fax:	

Please keep me informed with up-to-date information.

Your Interest

My interest is:

- Information only Possible purchase I have funding I am applying for funds

I intend to purchase

- Now! Within 3 months Within 6 months Within 12 months More than 12 months

- Salesperson please call

Please Send Product Information For:

Gratings & OEM

- Diffraction Gratings
 Pulse Compression Gratings
 OEM Spectrometers
 Imaging CCDs
 Multi Channel Imaging

Vacuum UV

- Monochromators & Spectrographs
 Mirrors
 Gratings

My Application is:

We would be interested in learning more about your application. Please give details below:

.....
.....

Comments

Please include any comments or further information about your requirement below:

.....
.....

USA - HORIBA Jobin Yvon Inc

Tel: +1-732-494-8660
Fax: +1-732-549-5125
Email: info@jobinyvon.net

France - HORIBA Jobin Yvon SAS

Tel: +33 (0) 1 64 54 13 00
Fax: +33 (0) 1 69 09 07 21
Email: info@jobinyvon.fr

Japan - HORIBA Ltd

Tel: +81 (0) 3 38618231
Fax: +81 (0) 3 38618259
Email: info@horiba.co.jp

Germany - HORIBA Jobin Yvon GmbH

Tel: +49 (0) 89 46 23 17-0
Fax: +49 (0) 89 46 23 17-99
Email: info@jobinyvon.de

Italy - HORIBA Jobin Yvon SRL

Tel: +39 0 2 57603050
Fax: +39 0 2 57600876
Email: info@jobinyvon.it

UK - HORIBA Jobin Yvon Ltd

Tel: +44 (0) 20 8204 8142
Fax: +44 (0) 20 8204 6142
Email: info@jobinyvon.co.uk

China - HORIBA Jobin Yvon SAS

Beijing representative office

Tel: +86 (0) 10 8567 9966
Fax: +86 (0) 10 8567 9066

Shanghai representative office

Tel: +86 (0) 21 3222 1818
Fax: +86 (0) 21 6289 5553
Email: jjh@jobinyvon.cn

HORIBA Jobin Yvon attempts to provide accurate information in this catalogue, however HORIBA Jobin Yvon assumes no responsibility should errors or inaccuracies

occur. HORIBA Jobin Yvon reserves the right to change the content without notice and provides this catalog "as is" with no warranty either express or implied.

COMPANY PROFILE

HORIBA Jobin Yvon is one of the world's largest manufacturers of analytical and spectroscopic systems and components and we are committed to serving our customers with superior products and technical support.

Established in 1819, Jobin Yvon is part of the HORIBA Group which employs more than 4,500 people worldwide, with annual sales in excess of \$900,000,000.

HORIBA Jobin Yvon, Sofie, Dilor, Spex and IBH are some of our well known and respected brand names.

HORIBAJOBIN YVON

USA: HORIBA Jobin Yvon Inc., 3880 Park Avenue, Edison, NJ 08820-3012, Toll-Free: +1-866-jobinyvon
Tel: +1-732-494-8660 Ext 232, Fax: +1-732-549-5125, E-mail: oem@jobinyvon.com, www.jobinyvon.com
France: HORIBA Jobin Yvon S.A.S., 16-18, rue du Canal, 91165 Longjumeau Cedex,
Tel: +33(0)164541338, Fax: +33(0)169099319, E-mail: oem.sales@jobinyvon.fr, www.jobinyvon.com
Japan: HORIBA Ltd., JY Optical Sales Dept, Higashi-Kanda, Daiji Building, 1-7-8 Higashi-Kanda
Chiyoda-ku, Tokyo 101-0031, Tel: +81 (0) 3 3861 8231, www.jyhoriba.jp
Germany: +49 (0) 89 462317-0 Italy: +39 0 2 57603050 UK: +44 (0) 20 8204 8142
China: +86 (0) 10 8567 9966

(All HORIBA Jobin Yvon companies were formerly known as Jobin Yvon)

Explore the future

HORIBA