



### APPLICATION NOTE # 104

### PL of Semiconductors

#### Introduction:

Photoluminescence spectroscopy (PL) is a powerful optical method used for characterizing materials. It can be used to find impurities and defects in silicon and group III-V element semiconductors, and to determine semiconductor band gaps. A material absorbs light, creating an electron hole pair; an electron from the valence band jumps to the conduction band leaving a hole. The photon emitted upon recombination corresponds to the energy difference between the valence and conduction bands, and is hence lower in energy than the excitation photon.

#### Experiment:

In order to measure photoluminescence of semiconductors, there are various requirements: (a) a stable, powerful monochromatic light source, (b) optics to focus light on the sample, (c) sample holder, (d) collection optics, (e) monochromator and (f) detector for spectral analysis. Actual sample excitation and collection optics used will depend on the type of samples and experimental conditions required. For some samples, excitation and collection are optimal at 90 degrees. In some cases it is also important to map an entire semiconductor wafer to analyze impurities found in different sample areas. Computerized mapping can be done with a precision x-y stage, and here usually the optics are positioned at zero degrees to the sample.

Various experimental parameters derived from the spectra such as peak symmetry, FWHM of the peak, center position of the peak, fine structure, can give information about the structure and composition of doped semiconductors. This type of analysis can also be used to evaluate growth methods using different input gas mixtures.

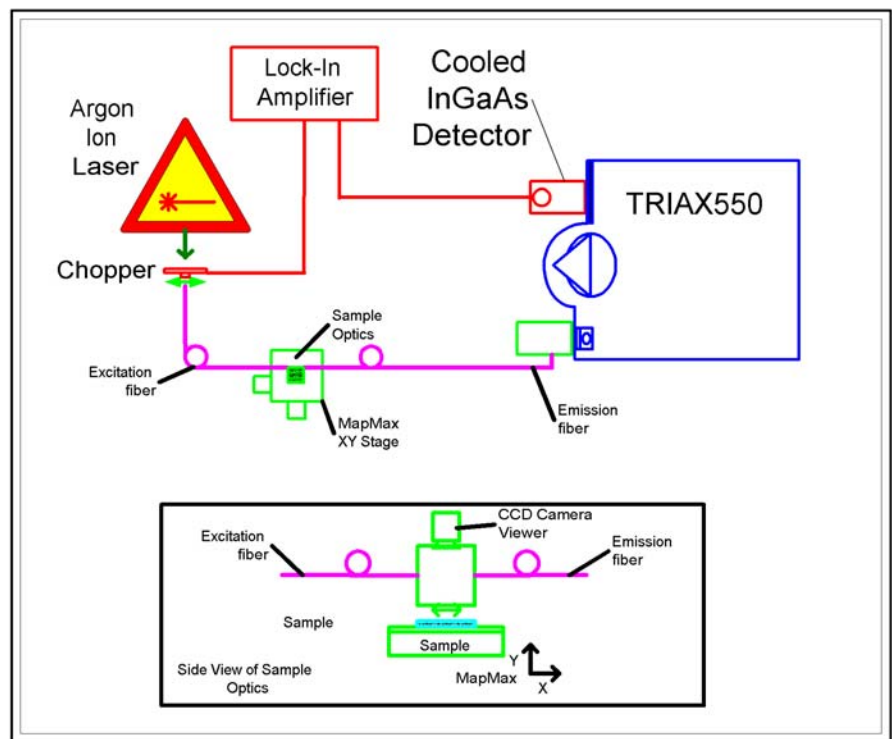

#### Features

- 500 to 2000 nm Operation
- Integrated Sample Optics and Viewer
- Precision XY Sample Positioning
- Specifically Designed for Cryostat Operation
- Integrated Data Collection and Analysis

#### Benefits

- Unique system for Continuous Monitoring from Visible to IR Without Realignment
- Optimize collected signal and Accurately target sample
- Automated Mapping Facility
- Ambient and Low Temperature Capabilities
- Completely Automated PL System



### APPLICATION NOTE # 104

### PL of Semiconductors

#### Results:

An example of a typical doped semiconductor photoluminescence spectrum obtained with a JY system is shown in Fig. 2. Here, a liquid nitrogen cooled InGaAs detector was used, for optimal sensitivity and low noise. The entire experiment is controlled by SpectraMax for Windows software, which provides easy data acquisition and analysis.

#### System configuration:

The diagram below shows the optical and mechanical arrangement of the photoluminescence system for analysis and mapping of a semiconductor sample. The sample is placed on the MapMax x-y translational stage and fixed in position in the sample holder. The JY Macro Illuminator allows light to be focused on the sample while the image is displayed on the monitor. An argon ion laser is used as the excitation source. Light from the laser is focused into a fiber, which goes into the input channel of the JY Macro Illuminator. The photoluminescence from the sample is collected, goes through the output channel of the JY Macro Illuminator, into a fiber, and finally into the Triax 550 monochromator for analysis.

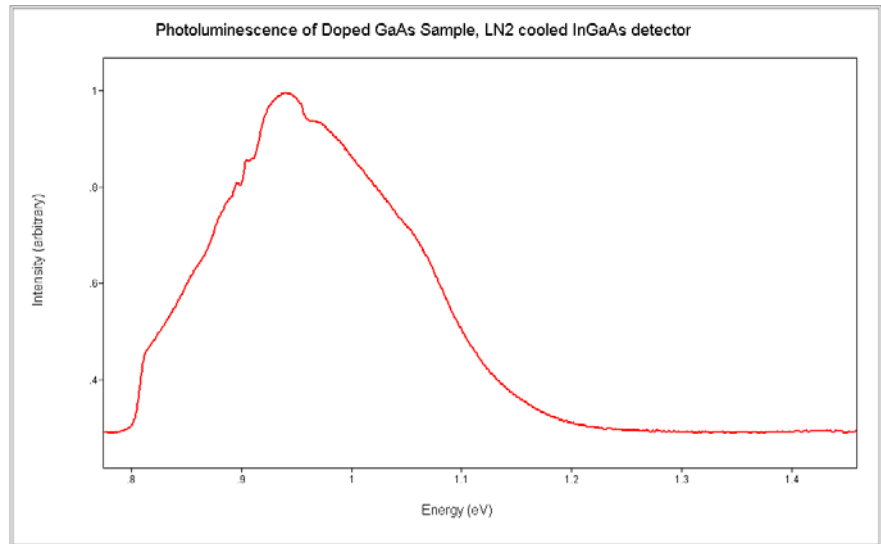

The excitation light is chopped, so that a lock-in amplifier can be used in conjunction with an InGaAs detector for data acquisition. After the initial system alignment is fixed, the experiment itself is controlled by computer using SpectraMax for Windows spectroscopy software

#### Conclusion:

A complete, nearly turn-key system for photoluminescence measurements from Jobin Yvon is shown to produce spectra with high signal-to-noise ratio, for diagnostic testing of semiconductors and other materials. A Jobin Yvon photoluminescence system provides a comprehensive solution for characterization of semiconductor materials.

#### In the USA:

Jobin Yvon Inc  
3880 Park Ave,  
Edison, New Jersey,  
08820 USA  
Tel: (732)-494-8660  
Fax: (732)-549-9309  
Email: OSD@jyhoriba.com

#### In France:

Jobin Yvon SA  
16-18 rue du Canal  
91165 Longjumeau cedex  
France  
Tel: (33) 1/64.54.13.00  
Fax: (33) 1/69.09.93.19

#### 1-877-JYHoriba

Germany: 89/46.23.17-0

Italy: 2/57.60.30.50

U.K. 020-8204-8142

