

Symphony

1024 x 256 Thermoelectric Front Illuminated CCD Detector

The Standard for Spectroscopy

The Jobin Yvon Front Illuminated 1024 x 256 CCD is ideal for low noise acquisitions required in a wide variety of spectroscopic applications. Its 26 μm x 26 μm pixel size offers a high full well capacity, a large dynamic range and an excellent signal to noise ratio. The height of this chip makes it the best choice for multi-tracking measurements or full 6.7 mm binning in the Visible to NIR spectral regions for an increased signal-to-noise ratio.

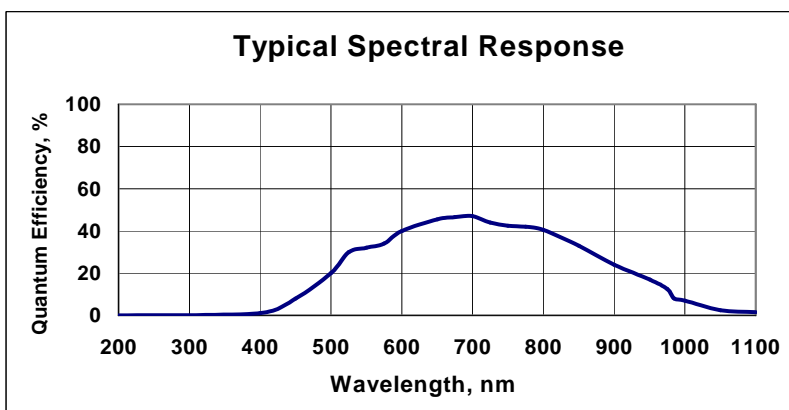

Features	Benefits
Scientific Grade 1 CCD	Ideally suited for low light level detection in a variety of spectroscopic applications
Thermoelectric Cooling	Low dark signal operation without the need for Liquid Nitrogen
Excellent Linearity	Increased accuracy of data over the full dynamic range
Software Selectable Scan Rates	Optimize an experiment for the best combination of speed and sensitivity
Ethernet Connection to Host PC	Standard, easy to use interface with 100% data integrity
HORIBA Jobin Yvon's SynerJY™ Software	Complete control of a Symphony CCD and HORIBA Jobin Yvon Spectrograph system with full analysis capabilities
LabVIEW VIs and SDK Available	Flexible software to integrate a Symphony CCD into existing apparatus or as an OEM component

Specifications				
CCD Format		1024 x 256, Front Illuminated, Scientific Grade 1		
Pixel Size		26 μm x 26 μm		
Image Area		26.6 mm x 6.7 mm, 100% Fill Factor		
Cooling System		4 Stage Thermoelectric Cooling		
		Minimum	Typical	Maximum
Readout Noise	20 kHz		3.4 e ⁻ rms	5 e ⁻ rms
	1 MHz		20 e ⁻ rms	25 e ⁻ rms
Pixel Well Capacity		350 ke ⁻	500 ke ⁻	
Register Well Capacity			1000 ke ⁻	
Dark Current			0.002 e ⁻ /pixel/s	0.005 e ⁻ /pixel/s
Nonlinearity		< 0.4 % at 20 kHz scan rate < 1 % at all other scan rates		
Scan Rates		Software Selectable from 20 kHz to 1 MHz		
Software Selectable Gains		5 Software Selectable Gains		
Dynamic Range		16 bits		
Vertical Shift Rate		48 μs , 24 μs , 8 μs ¹		
Maximum Spectral Rate	20 kHz	14 Hz		
	1 MHz	182 Hz ^{1,2}		

Specifications subject to change without notice.

Mechanical Dimensions

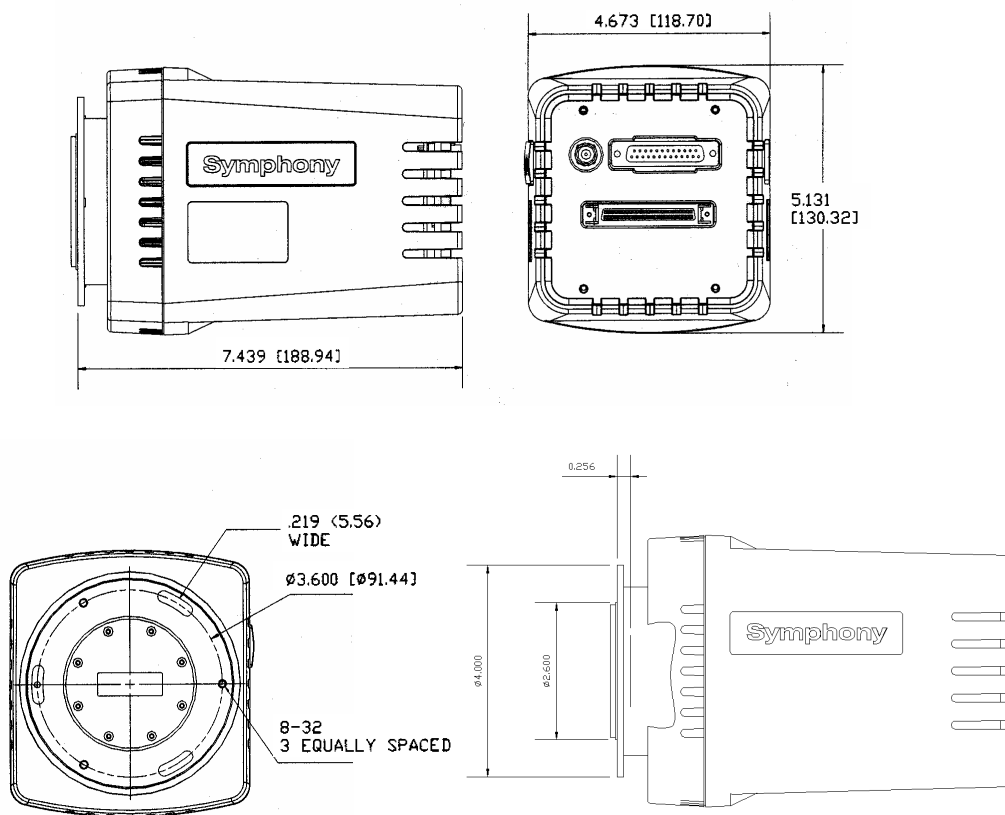

Units: Inches (mm)

Ordering Information:

CCD-1024x256-FIVS-STE Super Thermoelectric Cooled CCD System

Notes:

1 CCDs are guaranteed to have full Charge Transfer Efficiency at our standard shift rate of 48 μ s. At faster shift rates, a decrease in CTE may be observed

2 Highest Spectral rates are achieved when using the 1MHz ADC and a Parallel Transfer Time of 8 μ s