

Symphony

1024 x 128 Cryogenic Front Illuminated CCD Detector

The Standard for Small Slit Height Spectroscopic Applications

The Jobin Yvon Front Illuminated 1024 x 128 CCD detector is ideal for low noise acquisitions required in spectroscopic applications, such as Emission, Fluorescence, or Raman spectroscopy. Its 26 μm x 26 μm pixel format offers a high full well capacity, a large dynamic range and an excellent signal to noise ratio. The quality of this chip is comparable to the 1024 x 256 FIVS in a smaller format at a reduced cost. This detector is the best choice for fast acquisitions with a maximum spectral rate of 450 Hz.

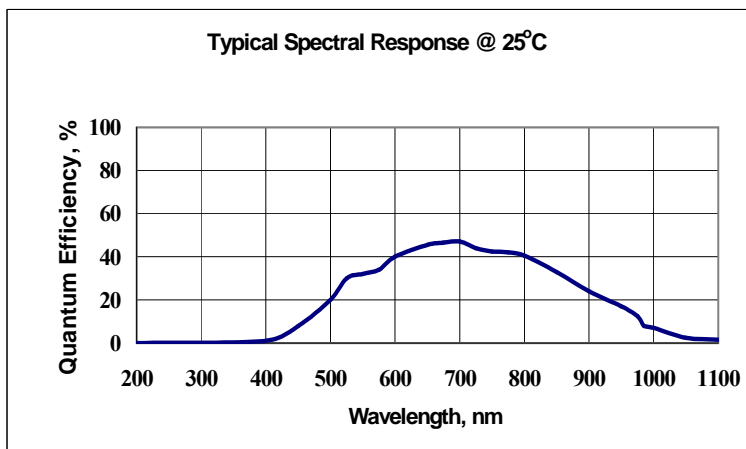

Features	Benefits
Scientific Grade 1 CCD	Ideally suited for low light level detection in a variety of spectroscopic applications
Front Illuminated CCD	Good spectral response from 400 nm – 1000 nm with no etaloning
Liquid Nitrogen Cooling	Extremely low dark signal operation for extended integration times required with low signal levels
Excellent Linearity	Increased accuracy of data over the full dynamic range
Software Selectable Scan Rates	Optimize an experiment for the best combination of speed and sensitivity
Ethernet Connection to Host PC	Standard, easy to use interface with 100% data integrity
HORIBA Jobin Yvon's SynerJY™ Software	Complete control of a Symphony CCD and HORIBA Jobin Yvon Spectrograph system with full analysis capabilities
LabVIEW VIs and SDK Available	Flexible software to integrate a Symphony CCD into existing apparatus or as an OEM component

Specifications				
CCD Format		1024 x 128, Front Illuminated, Scientific Grade 1		
Pixel Size		26 μm x 26 μm		
Image Area		26.6 mm x 3.3 mm, 100% Fill Factor		
Cooling System		Liquid Nitrogen		
Liquid Nitrogen Hold Time	1LS Model	24 hours with 1 Liter Dewar		
	3LS Model	72 hours with 3 liter Dewar		
		Minimum	Typical	Maximum
Readout Noise	20 kHz		3.5 e ⁻ rms	6 e ⁻ rms
	1 MHz		20 e ⁻ rms	25 e ⁻ rms
Pixel Well Capacity		350 ke ⁻	650 ke ⁻	
Register Well Capacity			1000 ke ⁻	
Dark Current			0.5 e ⁻ /pixel/hr	1 e ⁻ /pixel/hr
Nonlinearity		< 0.4 % at 20 kHz scan rate < 1 % at all other scan rates		
Scan Rates		Software Selectable from 20 kHz to 1 MHz		
Software Selectable Gains		5 Software Selectable Gains		
Dynamic Range		16 bits		
Vertical Shift Rate per row		48 μs , 24 μs , 8 μs ¹		
Maximum Spectral Rate	20 kHz	17 Hz		
	1 MHz	450 Hz ^{1,2}		

Specifications subject to change without notice.

Mechanical Dimensions

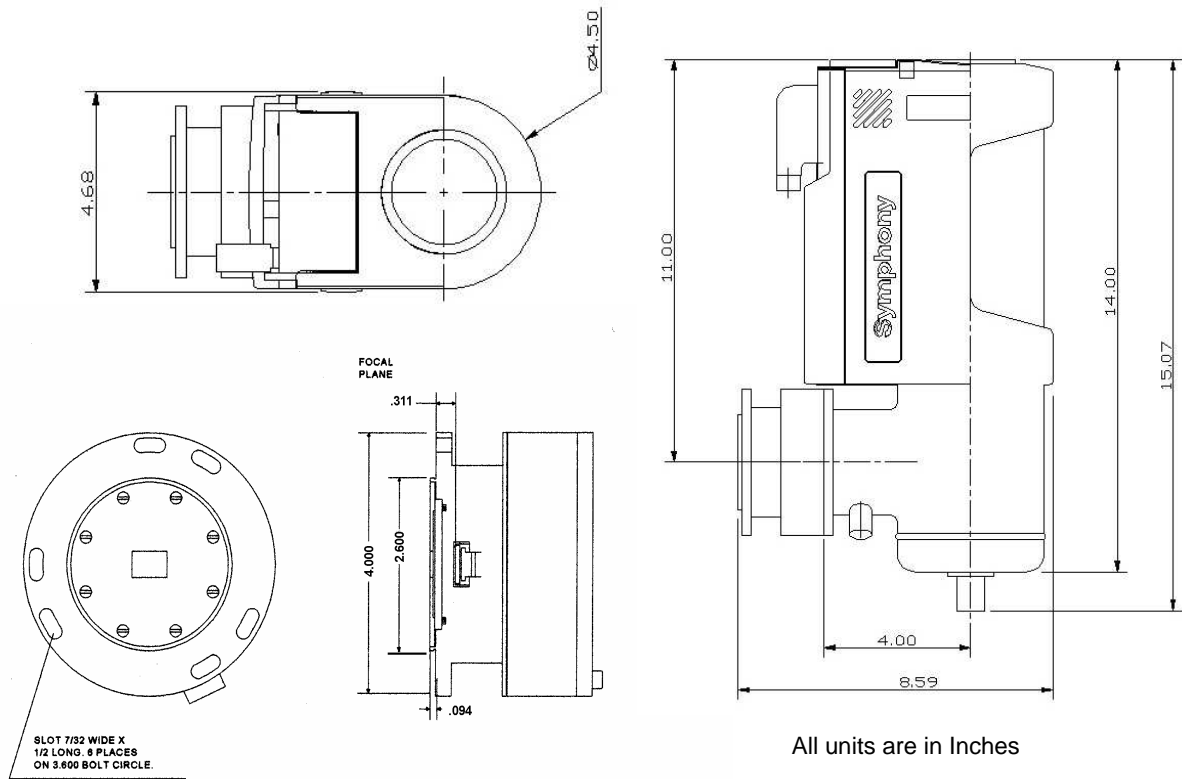

Ordering Information:

CCD-1024x128-FIVS-1LS	Liquid Nitrogen Cooled CCD System with 1 Liter Side Looking Dewar
CCD-1024x128-FIVS-3LS	Liquid Nitrogen Cooled CCD System with 3 Liter Side Looking Dewar
CCD-1024x128-FIVS-1LD	Liquid Nitrogen Cooled CCD System with 1 Liter Down Looking Dewar
CCD-1024x128-FIVS-3LD	Liquid Nitrogen Cooled CCD System with 3 Liter Down Looking Dewar

Our CCD packages include a CCD shutter for clean CCD charge transfer and background subtraction

Notes:

- 1 CCDs are guaranteed to have full Charge Transfer Efficiency (CTE) at our standard shift rate of 48 μ s. At faster shift rates, a decrease in CTE may be observed
- 2 Highest Spectral rates are achieved when using the 1MHz ADC, a Vertical Transfer Time of 8 μ s, and no mechanical shutter.