

Synapse™ CCD



The exceptional quantum efficiency of the HORIBA Jobin Yvon Back Illuminated 1024 x 256 CCD makes this detector ideal for extremely low level signal acquisitions of VIS and NIR spectroscopic applications. Better suited for emission spectroscopy where peaks are narrow, this detector can show etaloning effects with broad spectral bands found in Raman and Fluorescence applications.

Features

Benefits

Deep Thermoelectric Cooling	Low dark signal operation without the need for liquid nitrogen or auxiliary power
Excellent Linearity	Increased accuracy of data over the full dynamic range
Scientific Grade 1 CCD	Ideally suited for low light level detection in a variety of spectroscopic applications
Auxiliary Signal Input	Provides automatic reference corrections or extends wavelength scanning ranges with NIR detectors
Back Illuminated CCD	Highest Quantum Efficiency for greatest sensitivity
USB 2.0 Interface	Standard connection interfaces to PC notebooks and desktops with 100% data integrity
HORIBA Jobin Yvon's SynerJY® Software	Complete control of a Synapse CCD and HORIBA Jobin Yvon Spectrograph system with full analysis capabilities
LabVIEW VIs and SDK Available	Flexible software to integrate a Synapse CCD into existing apparatus or as an OEM component

Specifications

CCD Format		1024 x 256, Back Illuminated, Scientific Grade 1		
Pixel Size		26 μm x 26 μm		
Image Area		26.6 mm x 6.7 mm, 100% Fill Factor		
Cooling System		4 Stage Thermoelectric Cooling Guaranteed to -70 °C		
		Minimum	Typical	Maximum
System Read Noise	20 kHz		5 e- rms	8 e- rms
	1 MHz			20 e- rms
Pixel Well Capacity		300 ke-	500 ke-	
Register Well Capacity			1000 ke-	
Dark Current			0.004 e-/pixel/s	0.01 e-/pixel/s
Nonlinearity		< 0.4 % at 20 kHz < 1 % at 1 MHz		
Scan Rates		20 kHz and 1 MHz, Software Selectable		
Software Selectable Gains		3 Software Selectable Gains		
Dynamic Range		16 bits		
Vertical Shift Rates		36 μs , 8 μs^1		
Maximum Spectral Rate	20 kHz	13 Hz		
	1 MHz	280 Hz ^{1,2}		

Specifications subject to change without notice.

Notes:

1 CCDs are guaranteed to have full Charge Transfer Efficiency (CTE) at our standard shift rate of 36 μs . At faster shift rates, a decrease in CTE may be observed.

2 Highest Spectral Rates are achieved when using the 1 MHz ADC, a Vertical Transfer Time of 8 μs , with no mechanical shutter.

Quantum Efficiency

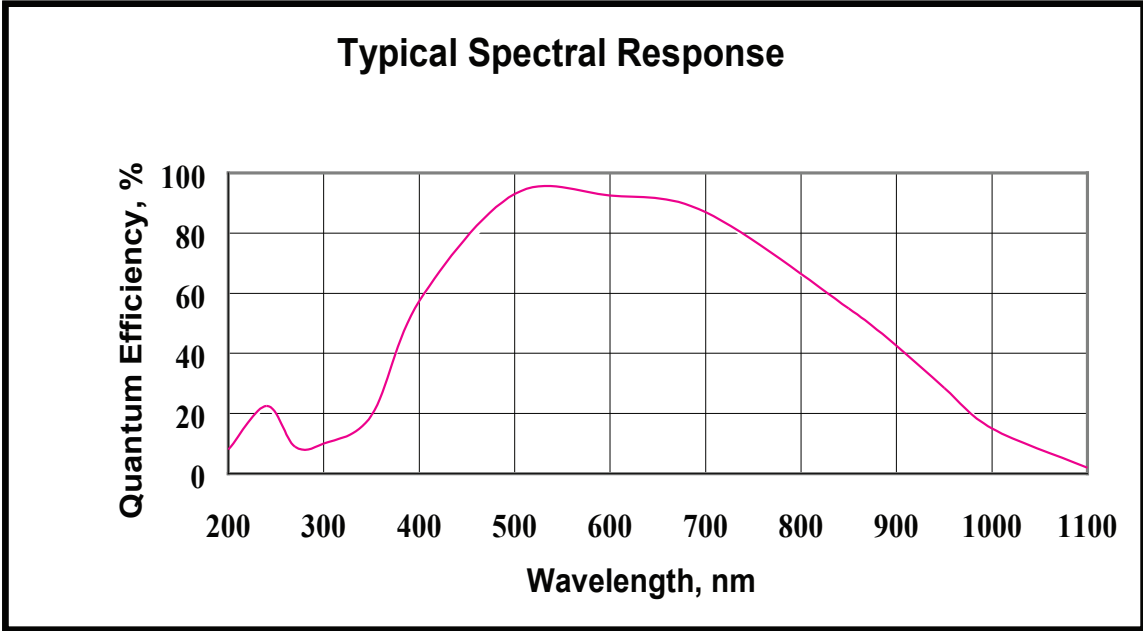

Mechanical Dimensions

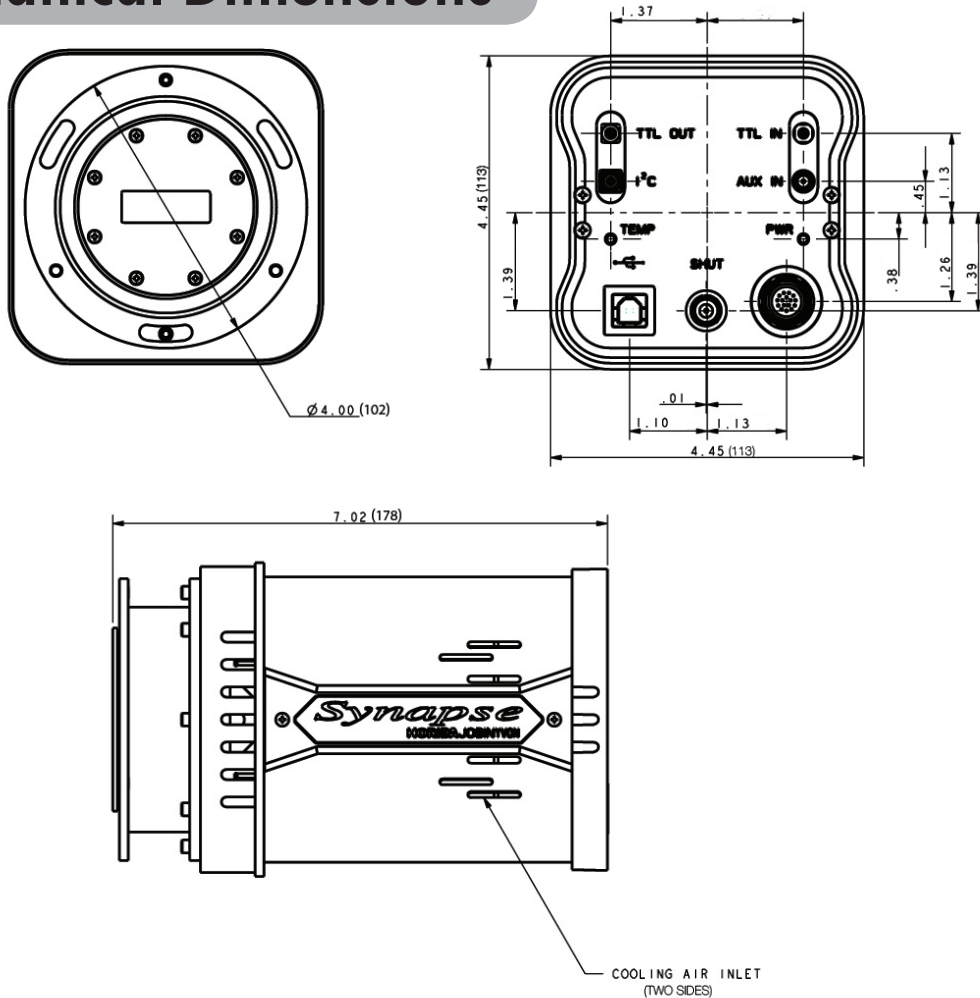

Configuration

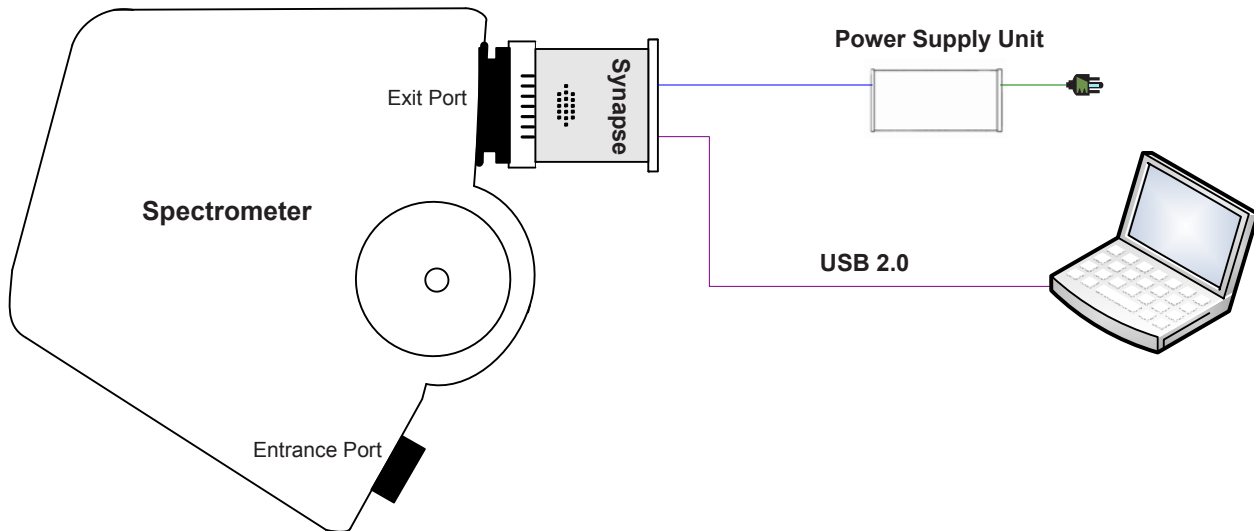

Spectrometer and computer are not supplied with the basic Synapse package.

Ordering Information

CCD-1024x256-BIVS-SYN: Synapse Thermoelectric Cooled CCD System

Our CCD packages include a CCD shutter for clean CCD charge transfer and background subtraction.