

Synapse™ CCD



The HORIBA Jobin Yvon Front Illuminated 1024 x 256 CCD is ideal for low noise acquisitions required in a wide variety of spectroscopic applications. Its 26 μm x 26 μm pixel size offers a high full well capacity, a large dynamic range and an excellent signal-to-noise ratio. The height of this chip makes it the best choice for multi-tracking measurements or full 6.7 mm binning in the VIS to NIR spectral regions for an increased signal-to-noise ratio.

Features

Benefits

Deep Thermoelectric Cooling	Low dark signal operation without the need for liquid nitrogen or auxiliary power
Excellent Linearity	Increased accuracy of data over the full dynamic range
Scientific Grade 1 CCD	Ideally suited for low light level detection in a variety of spectroscopic applications
Auxiliary Signal Input	Provides automatic reference corrections or extends wavelength scanning ranges with NIR detectors
Front Illuminated CCD	Good spectral response from 400 nm – 1000 nm with no etaloning
USB 2.0 Interface	Standard connection interfaces to PC notebooks and desktops with 100% data integrity
HORIBA Jobin Yvon's SynerJY® Software	Complete control of a Synapse CCD and HORIBA Jobin Yvon Spectrograph system with full analysis capabilities
LabVIEW VIs and SDK Available	Flexible software to integrate a Synapse CCD into existing apparatus or as an OEM component

Specifications

CCD Format		1024 x 256, Front Illuminated, Scientific Grade 1		
Pixel Size		26 μm x 26 μm		
Image Area		26.6 mm x 6.7 mm, 100% Fill Factor		
Cooling System		4 Stage Thermoelectric Cooling Guaranteed to -70 °C		
		Minimum	Typical	Maximum
System Read Noise	20 kHz		3.4 e- rms	5 e- rms
	1 MHz		15 e- rms	20 e- rms
Pixel Well Capacity		350 ke-	500 ke-	
Register Well Capacity			1000 ke-	
Dark Current			0.002 e-/pixel/s	0.005 e-/pixel/s
Nonlinearity		< 0.4 % at 20 kHz < 1 % at 1 MHz		
Scan Rates		20 kHz and 1 MHz, Software Selectable		
Software Selectable Gains		3 Software Selectable Gains		
Dynamic Range		16 bits		
Vertical Shift Rates		36 μs , 8 μs ¹		
Maximum Spectral Rate	20 kHz	13 Hz		
	1 MHz	280 Hz ^{1,2}		

Specifications subject to change without notice.

Notes:

1 CCDs are guaranteed to have full Charge Transfer Efficiency (CTE) at our standard shift rate of 36 μs . At faster shift rates, a decrease in CTE may be observed.

2 Highest Spectral Rates are achieved when using the 1MHz ADC, a Vertical Transfer Time of 8 μs .

Quantum Efficiency

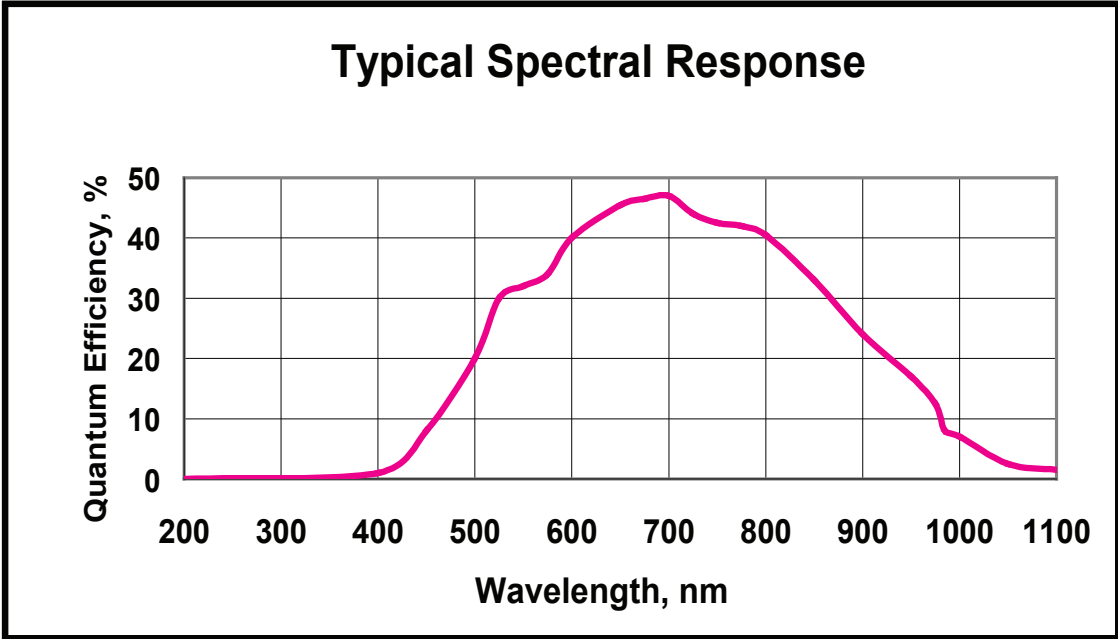

Mechanical Dimensions

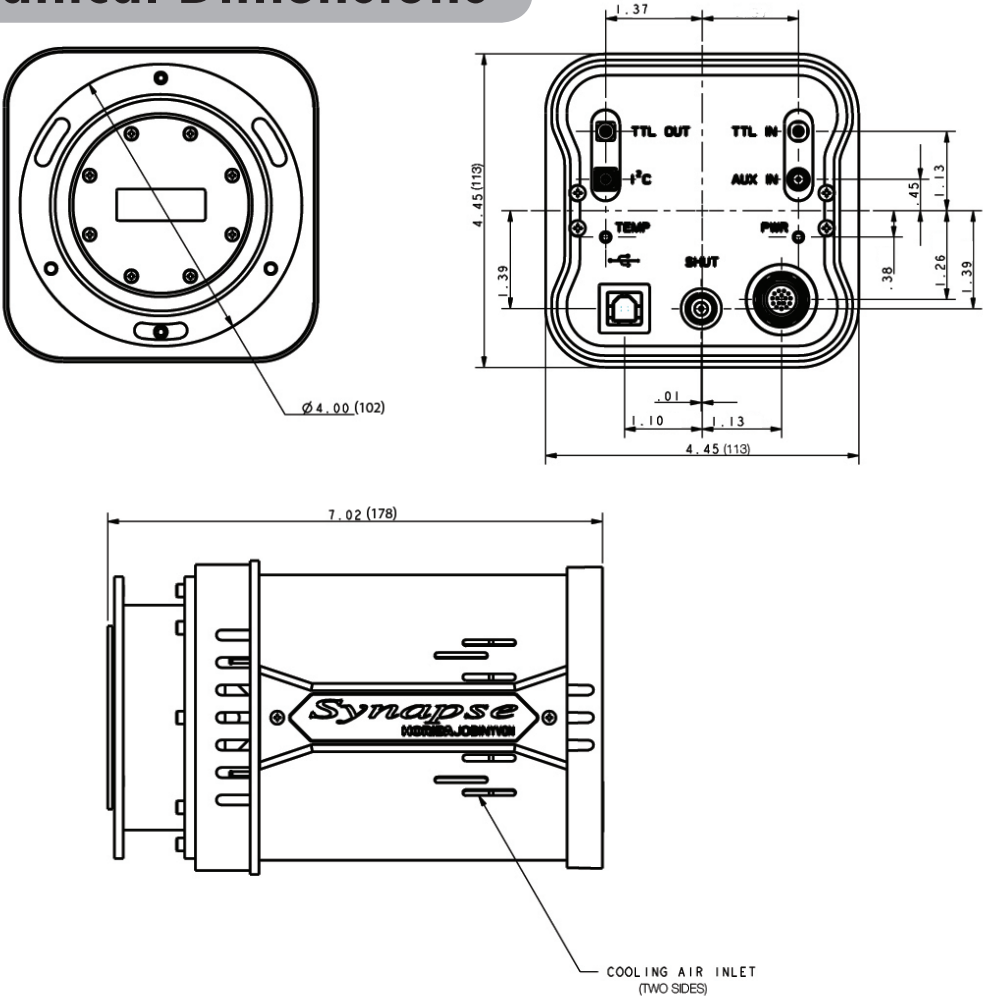

Configuration

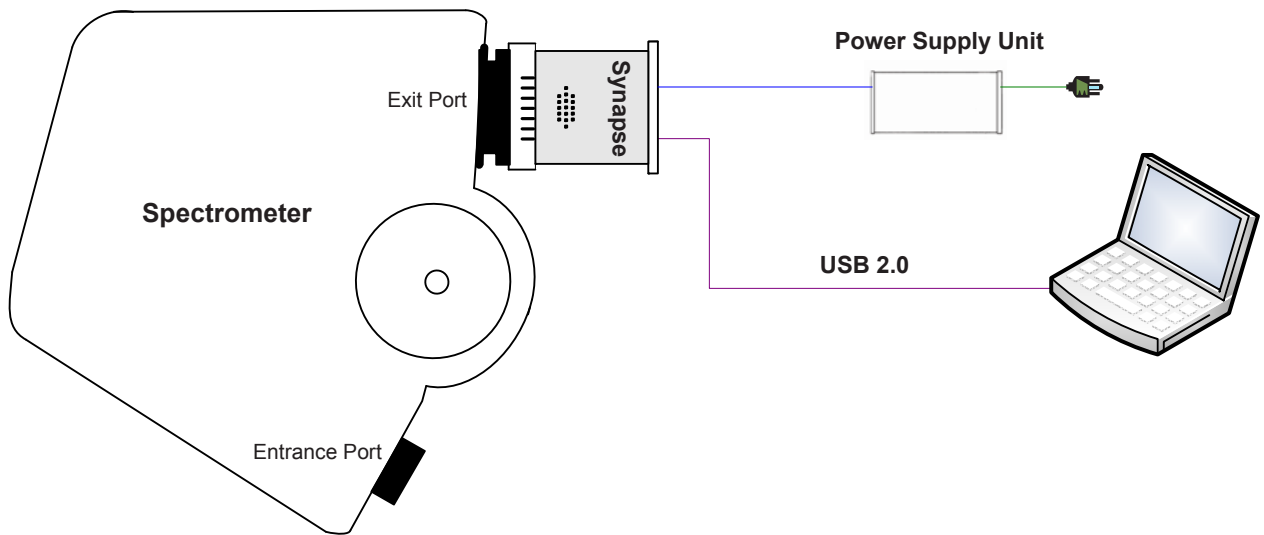

Spectrometer and computer are not supplied with the basic Synapse package.

Ordering Information

CCD-1024x256-FIVS-SYN: Synapse Thermoelectric Cooled CCD System

Our CCD packages include a CCD shutter for clean CCD charge transfer and background subtraction.