

XploRA™

Smart Microscopy

Combining microscopy and Raman chemical analysis

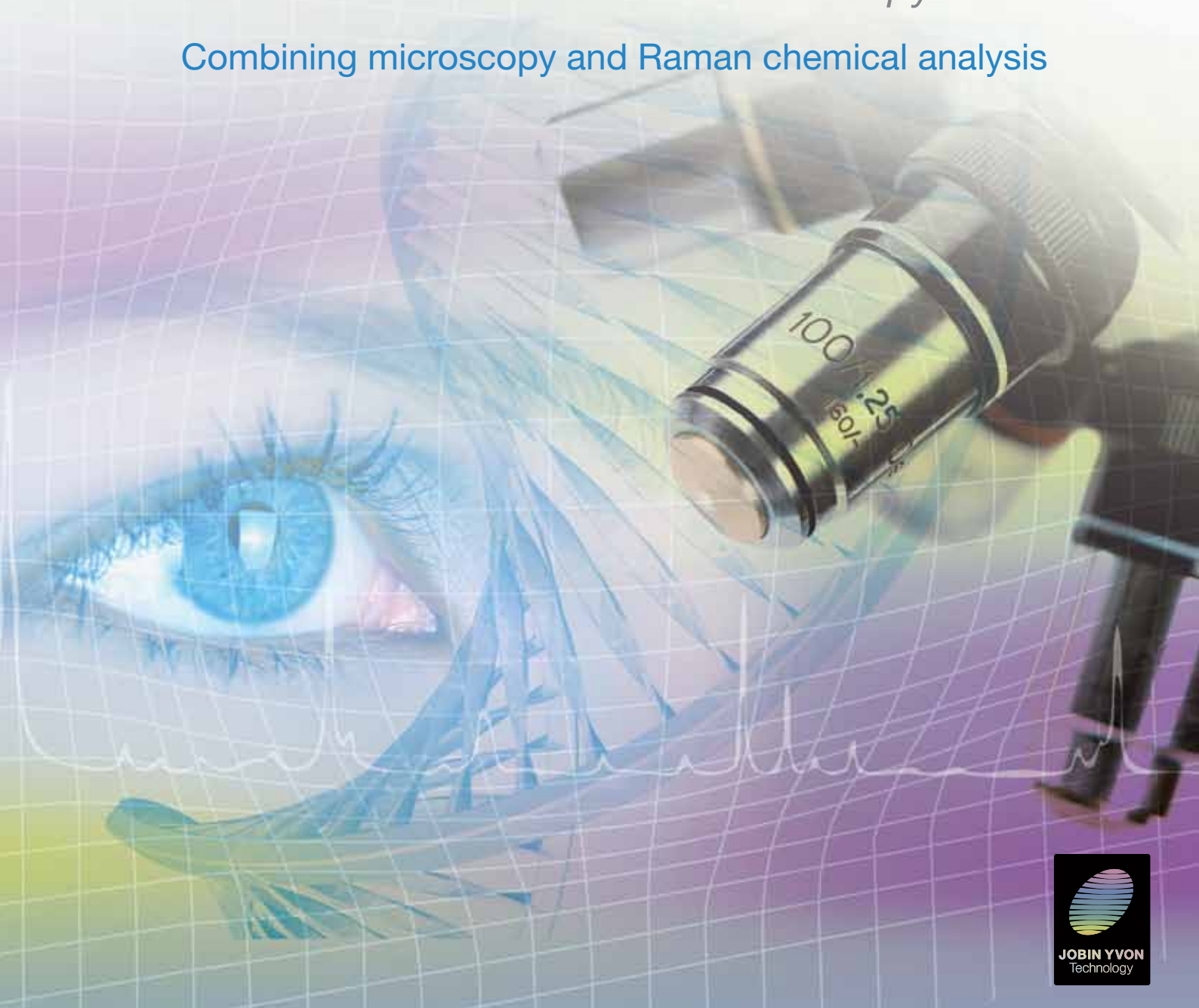

With more than four decades of experience in the field of Raman spectroscopy, HORIBA Jobin Yvon introduces a revolutionary and easy to use Raman microscope. The new XploRA™ completes the family bringing routine Raman microscopy to your lab.

Add chemical identification to your microscope images

This revolutionary Raman microscope brings chemical information to help solve your analytical questions.

Sensitive to inorganic and organic components, confocal Raman microscopy enables chemical analysis and imaging on the sub-micron scale. Molecular and chemical identification as well as the influence of environmental conditions (stress, temperature and pressure) can be monitored.

This non-destructive technique provides real-time structural and molecular analysis without any preparation of the sample.

The ultimate Smart Microscope for every R&D and QC lab.

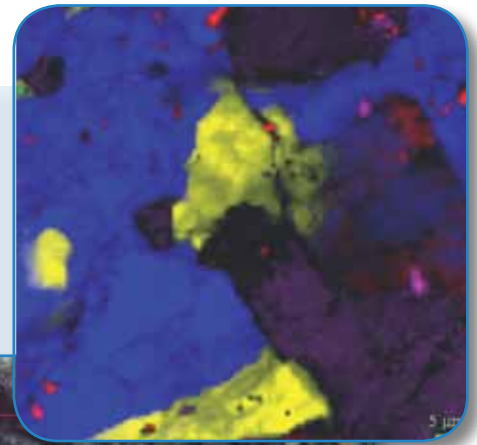

Raman image of a mineral sample

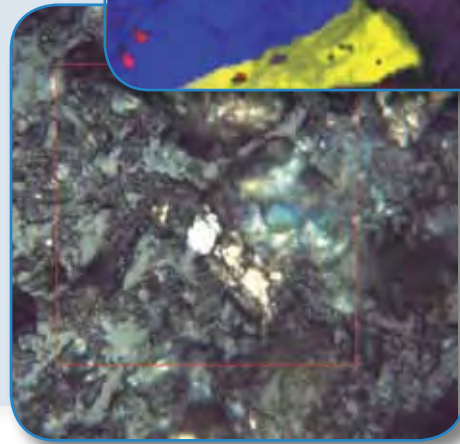

Optical image of a mineral sample

Explore the true nature of your sample!

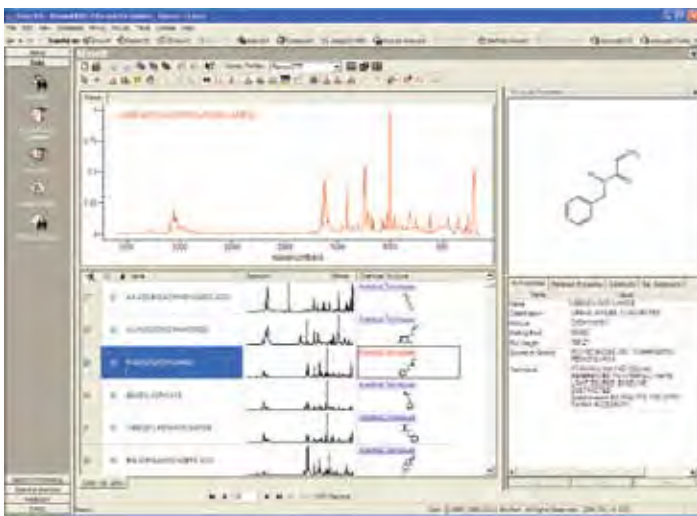

Capabilities

- Superimpose chemical images on your optical image
- Rapid compound identification through integrated spectral libraries
- Particle analysis and imaging with sub-micron resolution
- Molecular structure and phase analysis
- Kinetic processes and reaction monitoring

Benefits

- No sample preparation, measurements under atmospheric conditions
- Non-destructive, non-contact technique
- Minute sample quantities
- Liquid, solid or powder samples, including aqueous solutions

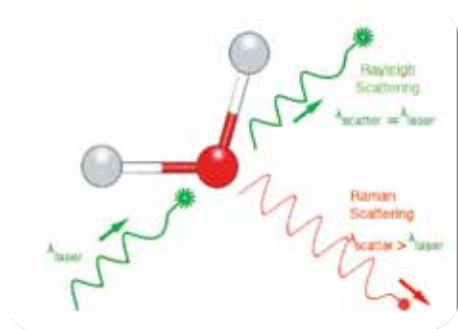

Smart Microscopy with Raman

Interaction of laser light with a sample results in a Raman spectrum - a detailed chemical fingerprint. Combined with an optical microscope, this provides sample identification and chemical imaging on a microscopic scale.

A safe and extremely sensitive technique: it is one of the most powerful and easy to use analytical techniques now available. A truly SMART microscopy.

System

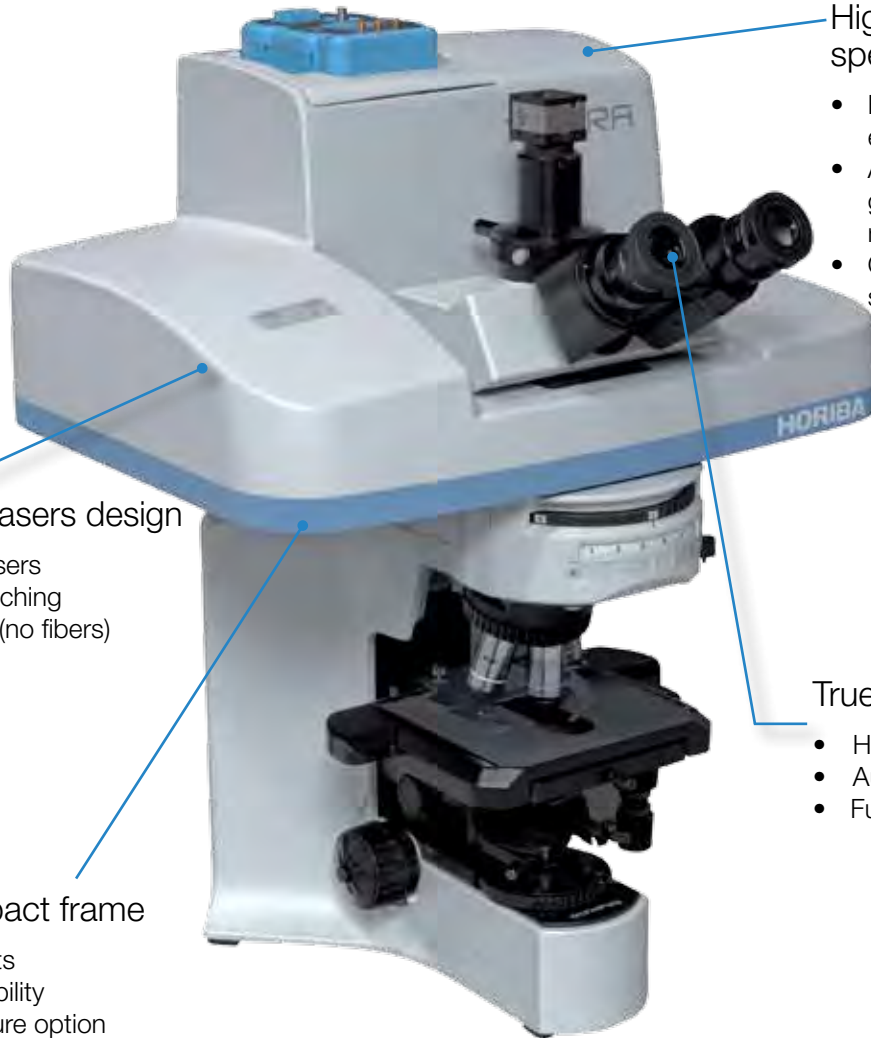

High sensitivity Raman spectrometer

- High optical throughput for enhanced sensitivity
- Automated 4-positions grating turret for optimal resolution
- Optical fiber port for remote sampling

Compact multiple lasers design

- Up to 3 integrated lasers
- Automated laser switching
- Direct laser coupling (no fibers)

True confocal microscope

- High spatial resolution
- Automated mapping stages
- Full microscope options

Rugged and compact frame

- Very few moving parts
- High mechanical stability
- Class 1 laser enclosure option

Enter a new dimension in microscopy

Performance and simplicity

The XploRA™ turns a new page in microscopy. With an intuitive interface and full automation, Raman analysis has never been easier. Chemical identification and chemical imaging can now be performed on solid or liquid samples at the touch of a button. Whether for routine sample identification, quantitative analysis or chemical imaging, the XploRA™ combines performance and simplicity in a cost effective system.

Easily portable

The light, compact design of the XploRA™ makes it easy to transport from lab to lab or for on-site analysis at archeological sites, crime scenes or in a mobile laboratory.

Rugged by design

The XploRA™ is designed with long lifetime optics and few moving parts for unsurpassed stability and zero maintenance. Fast start up and self-validation protocols yield reliable measurements, time after time.

Intuitive operation

Designed with ease-of-use in mind, the XploRA's intuitive software and hardware interface allows you to quickly get results, even with little or no experience in Raman spectroscopy. The XploRA™ provides simple and precise sample analysis everytime.

The XploRA™ features:

- Full microscope observation capabilities with point-and-shoot chemical analysis
- Fast chemical identification through automated spectral library searches
- True confocal microscopy for high resolution 3D chemical imaging and detailed particle analysis
- Plug-and-play operation
- Class I laser safety enclosure option

Applications



PHARMACEUTICALS

Identification and distribution of a tablet's API (Active Pharmaceutical Ingredient) and excipient can be studied by Raman Imaging. In this image, a tablet has been mapped to determine component particle size and distribution, crucial information for understanding product performance and quality. The XploRA™ is also an invaluable addition to your analytical toolbox when it comes to demonstrating patent infringement or the detection of counterfeit products.



FORENSICS

Narcotics, polymers, explosives, pigments and biological residues generally exhibit rich Raman spectra. Confocal Raman microscopy provides an ideal method for the study of these materials. In the image on the left, the Raman mapped image enables the characterization of the structure and composition of plastic packaging. The multi-layer film consists of more than 10 layers ranging in thickness from 1 to 50 μm ; all the layers are easily analyzed with the XploRA™.

Sample courtesy of Sabine Bebelman, Université Catholique de Louvain, Belgium

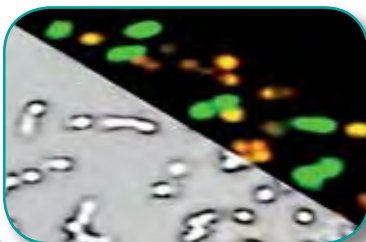

BIOLOGY

Raman spectroscopy is extremely sensitive to subtle changes within bio-molecules. For example, disease diagnosis, micro-biology, drug interactions, tissue healing, dermatology and cosmetics can all benefit from the information-rich analysis of Raman. The XploRA's sensitivity even allows single cell bacteria to be identified and classified in a straightforward manner. In this image, single bacteria have been imaged according to their carbon isotope content (^{12}C and ^{13}C).

Sample courtesy of Dr Wei Huang, University of Sheffield, UK

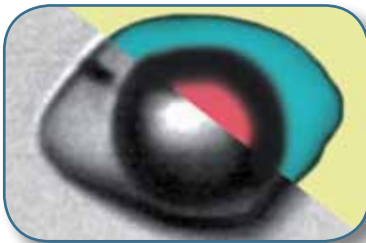

GEOLOGY/GEMMOLOGY

Confocal Raman spectroscopy allows mineral species to be identified and their distribution mapped with high spatial resolution. In addition, fluid inclusions can be analysed *in situ*. Here, a 20 μm inclusion has been analysed without any sample preparation. The high spatial discrimination of the XploRA™ allows both the liquid region and 10 μm gas bubble (CO_2 , N_2 and CH_4 gases) to be distinguished with ease.

Sample courtesy of Dr Gauthier, UFR des Sciences de la Terre, USTL, France

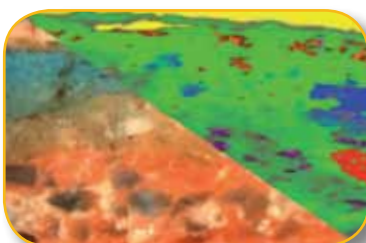

ARCHEOLOGY/ART

In art conservation and archeology Raman spectroscopy is used for the study of pigments, ceramics, glasses and corrosion products, providing information on the origin, the craft technique, conservation, history and authenticity of an object. Shown on the left, individual pigment particles in a fragment of mixed paint are identified using Raman. For example, the red pigment is shown to be Haematite, an iron oxide pigment.

Sample courtesy of Polonca Ropret, Restauration Center, Slovenia

Features

Get to full speed at once with LabSpec

The XploRA™ comes with HORIBA Scientific's LabSpec 6 software platform, built on the success of its award winning previous versions, to deliver a unique environment for complete instrument control and data processing.

As the link between users and HORIBA's cutting edge instrumentation, LabSpec 6 offers an intuitive interface which enables logical work flow through an experiment, from visualization of the sample and measurement set up, to interpretation of the data, and final reporting of the results. Recordable "analysis methods" can be created to simply automate multiple processes, and customize experiments.

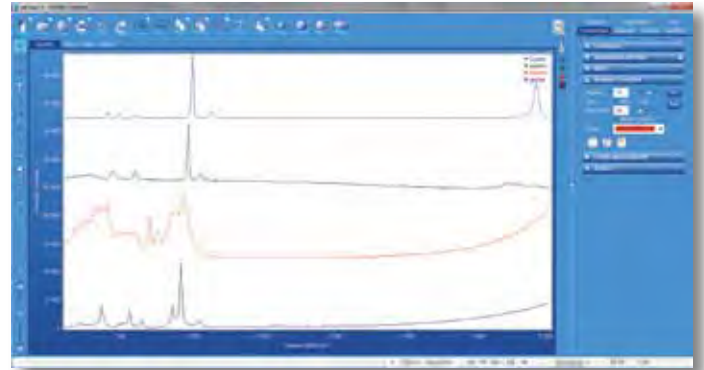

To make your analysis faster and easier, LabSpec features:

- Methods and templates – create customized analysis procedures, and recall configuration templates
- AutoCAL - auto-calibration and self-validation function for reliable and validated results everytime
- Spectral databases and interpretation tools – fast chemical identification powered by KnowItAll® [option]

Technical specifications

Spatial resolution	< 1 μm (XY); < 2 μm (Z)
Spectral dispersion	0.7 $\text{cm}^{-1}/\text{pixel}$ @532 nm*; 0.4 $\text{cm}^{-1}/\text{pixel}$ @785 nm* *Automated selection of spectral resolution and coverage through grating selection
Laser excitation (up to three internal lasers)	532 nm, 638 nm, 785 nm
Spectrograph	High throughput integrated spectrograph
Detector	1" chip, high sensitivity air cooled CCD
Laser power control	100 %, 50 %, 25 %, 10 %, 1 %, 0.1 %

Peripherals

- Automated XYZ mapping with autofocus
- Light microscopy - dark field, phase contrast, DIC
- Reflected/transmitted light illumination
- Heating/cooling stages
- Multiwell plates for high-throughput screening
- Raman polarisation optics
- Macro measurement accessory
- Cuvette holder for liquid measurements
- Fiber-coupled probes for remote analysis
- Chemometrics package for spectral imaging

Safety and compliance

- Class I laser enclosure option
- 21 CFR11 compliant
- IQ/OQ/PQ available



Environment

- Weight: 35 kg (77 lbs)
- Operating temperature: 15-28°C

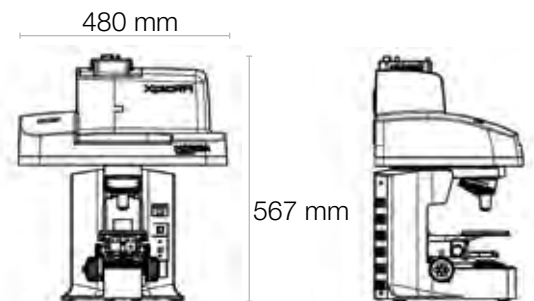

Innovative Solutions

The HORIBA Group provides superior technologies, unique products, and high quality services in the analytical and measurement fields. HORIBA Jobin Yvon is part of the HORIBA Group.

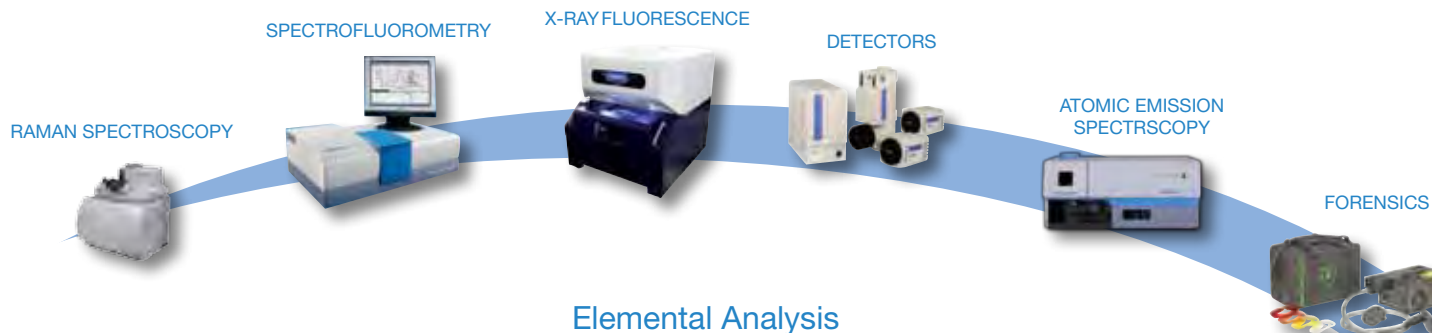

Elemental Analysis

- ICP-OES
- GD Spectrometry
- C/S, O/N/H Analyzers
- Sulfur and Chlorine Analysers

Molecular and Microanalysis

- Raman Spectroscopy
- Spectrofluorometry
- X-RAY Fluorescence
- Photoluminescence
- Surface Plasmon Resonance imaging

Optical Components

- Diffraction Gratings
- Spectrometers
- VUV Instrumentation
- Modular Optical Spectroscopy
- Detectors

www.horiba.com/scientific

Other techniques

- Optical Characterization of Thin Films
 - Particle Size Analysis
 - Forensics

CUSTOM GRATINGS
AND VUV BEAMLINES



OEM SPECTROMETERS
AND GRATINGS



OPTICAL SPECTROSCOPY



PARTICLE SIZE ANALYSERS



ELLIPSOMETRY

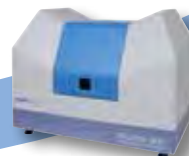

SPRI



- The content of this catalogue is subject to change without prior notice
- It is forbidden to copy from the contents of this catalogue in part or in full
- Please read the instruction/operation manual before using these products

This instrument complies with 21CFR 1040.10 and EN 60825-1 (01/2008)



CLASS 1 LASER PRODUCT

$\lambda = (400 \text{ nm} - 850 \text{ nm}) P < 150 \text{ mW}$
VISIBLE AND INVISIBLE LASER RADIATION
AVOID EXPOSURE TO BEAM
CLASS 3B LASER PRODUCT

* Laser safety classifications depend on individual systems and options

info.sci@horiba.com
www.horiba.com/scientific

HORIBA
 Scientific

USA: +1 732 494 8660
UK: +44 (0)20 8204 8142
Spain: +34 91 490 23 34
Other Countries: +33 (0)1 64 54 13 00

France: +33 (0)1 64 54 13 00
Italy: +39 0 2 5760 3050
China: +86 (0)10 8567 9966

Germany: +49 (0)89 4623 17-0
Japan: +81 (0)3 38618231
Brazil: +55 11 5545 1540