

# H30-UVL

Monograph for Far and Extreme Ultraviolet

The next stage  
of the vacuum spectroscopy

**True flat field**

**Compact**

versatile

**Fast drive**

USB2

**High EUV-UV**

**Controller less**



## A monograph to explore the 50–300nm spectral range

The H30-UVL is especially designed for analyzing from high EUV to UV range in high vacuum environment and can be used as a monochromator (slit-slit) or spectrograph (slit-CCD).



H30-UVL in spectrograph mode

The H30-UVL is built around a single toroidal aberration corrected grating using the holographic VLS technology. It has been especially calculated to reduce astigmatism not only on its optical axis but over a large exit plane in all directions (25 x 10 mm corrected plane) making it ideal for one inch arrays. Its single grating layout has the other advantage to reduce the number of optics in the instrument to the minimum, increasing its throughput in EUV and FUV regions.

### Applications

- Tunable light source
- FUV Reflectometry/Absorption
- Plasma Physics Study
- High Harmonic Generation

### Features

- Single Toroidal Grating design
- Low astigmatism level
- Corrected imaging plane
- MgF<sub>2</sub> coating UV optimized
- Interchangeable Exit port
- Automated drive
- Built-in USB2 interfaces
- High Vacuum compatible

### Benefits

- Optimized for throughput
- High S/N ratio measurement
- Flat field monograph
- Better efficiency in FUV range
- Choice of exit slit or CCD port
- Fast and easy to operate
- No additional controller and easy computer control
- 10<sup>-6</sup> mbar – optional 10<sup>-9</sup> mbar (UHV)

## Variable Line spacing Gratings

The H30-UVL is using an aberration-corrected VLS toroidal grating which disperses and refocus the light from the entrance slit onto the exit focal plane of the monograph.

The wavelength selection and the scanning are obtained through a simple rotation of the grating.

The groove spacing of these gratings is computer-optimized to produce high quality images with a minimum of astigmatism and coma over a large spectral range and even at high numerical aperture.

The VLS grating grooves are no longer straight and parallel, but instead correspond to confocal hyperboloids or ellipsoids. Optimizing the position, angles and arm lengths of the two recording beams provides the optical designer with the degrees of freedom necessary to minimize aberrations.



## Toroidal rotating grating providing a flat field spectrum

### A corrected grating for a compact and simple design

The H30-UVL design with two fixed ports and a rotated grating for the wavelength selection, simplifies any alignment in your experiment compared to Rowland circle based instruments equipped with a rotating arm.

Thanks to the corrected grating that provides a true flat field spectrum whatever the selected wavelength, the exit port can be either a slit or a CCD port.

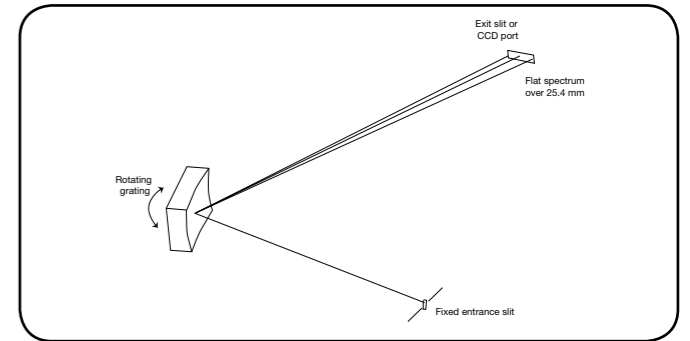

H30-UVL optical layout

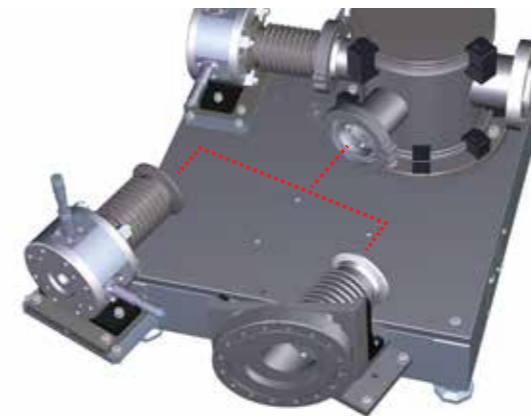

Exit port easily interchangeable by user from slit to CCD port

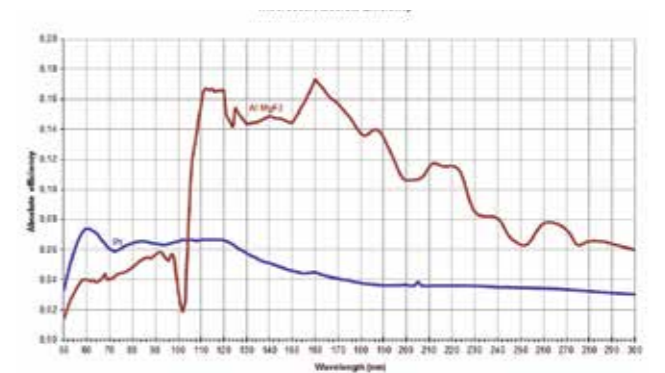

Theoretical absolute efficiency of H30-UVL with a Pt and AlMgF<sub>2</sub> coating

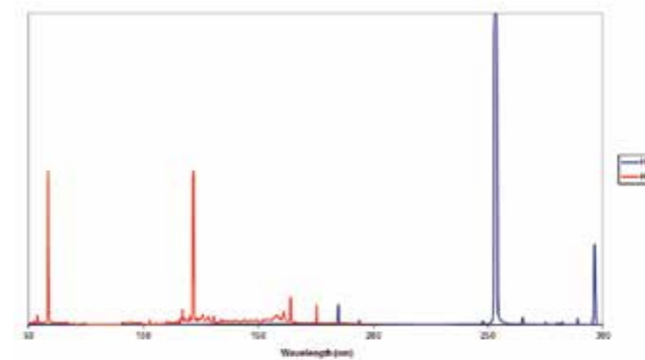

He and Hg spectra recorded with a H30-UVL in monochromator mode



He spectrum recorded with a H30-UVL in spectrograph mode. VLS gratings make proper corrections to have the best image at the exit of instruments.

### Options

- Exit port can be adjustable slit and/or adjustable CCD port
- Removable entrance arm
- Laser kit for easy alignment

### Accessories

- UV Light Sources
- Single channel detection
- CCD detectors

# H30-UVL Specifications

<b>Optical design</b>	Toroidal VLS Grating (single optic)
<b>Focal length</b>	274 mm
<b>Aperture</b>	f/6
<b>Grating density</b>	1200 gr/mm
<b>Grating type</b>	Replica (Master in option)
<b>Optic coating</b>	AlMgF <sub>2</sub> optimized at 121 nm or Pt
<b>Deviation angle</b>	70°
<b>Dispersion</b>	2.3 nm/mm at 50 nm
<b>Drive</b>	Fast worm drive
<b>Resolution</b>	Better than 0.2nm (*)
<b>Vacuum</b>	10 <sup>-6</sup> mbar
<b>Pumping flange</b>	DN63 CF
<b>Entrance port</b>	Micrometric slits (10 µm to 2 mm)
<b>Exit port</b>	Micrometric slits (10 µm to 2 mm) or adjustable CCD port
<b>Entrance flange</b>	DN40 KF
<b>Exit flange</b>	DN40 KF for slit version, DN100CF for CCD version
<b>Software</b>	HORIBA Scientific software
<b>PC Interface</b>	Built-in USB2 – No additional controller

## Variation of the dispersion with wavelengths

As the spectral dispersion at the exit of a monochromator varies with the wavelength selection, the maximum spectral resolution of the monochromator depends on wavelength changes.

Wavelength (nm)	Dispersion (nm/mm)
50	2.3
175	2.5
300	2.6

## Spectral range analyzed with 1 inch CCD in Spectrograph Mode

Central wavelength (nm)	Spectral range on the CCD	
	nm	eV
50	21 - 80	15 - 60
150	120 - 180	7 - 10
300	270 - 330	4 - 5

\* using 10 micron slit and 2 mm slit height at 121 nm in monochromator mode

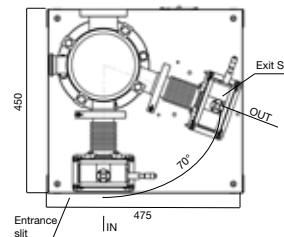
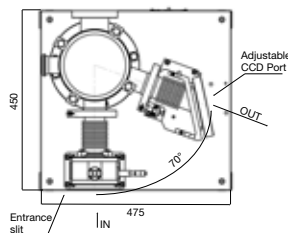
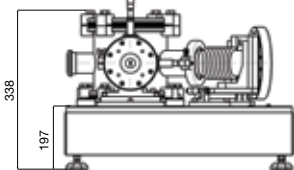
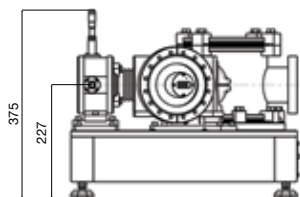

[www.horiba.com/scientific](http://www.horiba.com/scientific)  
[info.sci@horiba.com](mailto:info.sci@horiba.com)

**France:** HORIBA Jobin Yvon S.A.S., 16-18 rue du Canal, 91165 Longjumeau cedex - Tel: +33 (0)1 69 74 72 00 - Fax: +33 (0)1 69 09 07 21 - Email: [info-sci.fr@horiba.com](mailto:info-sci.fr@horiba.com)  
**USA:** HORIBA Instruments Inc., 3880 Park Avenue, Edison, NJ 08820-3012 - Toll-free: +1-866-562-4698 - Tel: +1 732 494 8660 - Fax: +1 732 549 5125 - Email: [info-sci.us@horiba.com](mailto:info-sci.us@horiba.com)  
**Japan:** HORIBA Ltd., Tokyo Branch Office, 2-6, KandaAwaji-cho, Chiyoda-ku, Tokyo 101-0063, Japan - Tel: +81-(0)3 6206 4721 - Fax: +81 (0)3 6206 4730 - Email: [info-sci.jp@horiba.com](mailto:info-sci.jp@horiba.com)  
**Germany:** HORIBA Jobin Yvon GmbH, Hauptstrasse 1, 82008 Unterhaching - Tel: +49 (0)89 4623 17-0 - Fax: +49 (0)89 4623 17-99 - Email: [info-sci.de@horiba.com](mailto:info-sci.de@horiba.com)  
**Italy:** HORIBA Jobin Yvon Srl., Via Cesare Pavese 21, 20090 Opera (Milano) - Tel: +39 2 5760 3050 - Fax: +39 2 5760 0876 - Email: [info-sci.it@horiba.com](mailto:info-sci.it@horiba.com)  
**UK:** HORIBA UK Ltd., 2 Dalston Gardens, Stanmore, Middlesex HA7 1BQ - Tel: +44 (0)20 8204 8142 - Fax: +44 (0)20 8204 6142 - Email: [info-sci.uk@horiba.com](mailto:info-sci.uk@horiba.com)  
**China:** HORIBA (China) Trading Co. Ltd., Unit D 1F, Bldg A, Srynnex International Park, No. 1068 West Tianshan Road, Shanghai 200335 - Tel: +86 (0)21 6289 6060 - Fax: +86 (0)21 6289 5553  
 Email: [info-sci.cn@horiba.com](mailto:info-sci.cn@horiba.com)  
**Brazil:** HORIBA Instruments do Brasil Ltda., Rua Presbitero Plinio Alves de Souza, 645, Lotiamento Polo Multivias, Bairro Medeiros-Jundiai, São Paulo CEP 13.212-181  
 Tel: +55 (0)11 2923 5400, Email: [infocientifica.br@horiba.com](mailto:infocientifica.br@horiba.com)  
**Other:** Tel: +33 (0)1 69 74 72 00 - Email: [info.sci@horiba.com](mailto:info.sci@horiba.com)

# HORIBA

Scientific