

PGM-Series

Plane Grating Monographs

Straight by Design

**Imaging
Correction^{PLUS}
Technology**

Wide spectral range

True Flat Field

EUV Spectroscopy

**Monograph
Design**



Monographs to explore the 7-175 nm spectral range

Variable Line Spacing Gratings

Our PGMs use VLS gratings combined with toroidal mirrors. The combination of these two optics disperses and refocuses the light from the entrance slit onto the exit focal plane of the monograph.

The wavelength selection and the scanning are obtained through a simple rotation of the grating.

The groove spacing of VLS gratings and the parameters of the associated toroidal mirror are both optimized with our Imaging Correction^{PLUS} Technology that produces high quality images with minimum astigmatism and coma over a large spectral range and even at high numerical aperture.

The VLS grating grooves are no longer straight and parallel, but instead correspond to confocal hyperboloids or ellipsoids. Optimizing the position, angles and arm lengths of the two recording beams provides the optical designer with the degrees of freedom necessary to minimize aberrations.

The PGM (Plane Grating Monograph) series are especially designed for analyzing Extreme UV (EUV) to Far UV (FUV) as a monochromator (slit-slit) or spectrograph (slit-CCD port).



PGM1000 in spectrograph configuration, customized with a top pumping port

Instead of having a fixed spherical grating and the exit port rotating on the Rowland circle like most of the other common designs, our PGM is straight (the entrance and exit arm are parallel) and both entrance and exit ports are fixed, making our compact PGM a very easy solution to integrate into your existing setup.

Applications

- High Harmonic Generation
- Plasma Physics Study
- VUV Laser Analysis
- Study of High Harmonics Filters
- FUV/EUV Spectroscopy
- XPS
- EUV Reflectometry

Features

- Imaging Correction^{PLUS} Technology
- On Axial optical design
- Choice of master or replica gratings
- Kinematic Grating Mount or three gratings slider
- CCD port mounted on X table
- Patented layout

Benefits

- The best image on your CCD over 25 mm focal plane
- Less room needed and easy to align
- Optimize damage threshold or cost
- Interchangeable gratings
- In vacuum focus adjustment
- Use grazing incidence angles onto the optics and normal incidence for CCD illumination

A corrected grating for original optical layout

A versatile and interchangeable exit port

Based on our unique optical design coupling a toroidal mirror and an aberration corrected plane grating, the PGM can be used both as a monochromator (with an exit slit) or as a flat field spectrograph (with CCD port).

Flat-field focus plane being always perpendicular to the exit axis of the instrument, the CCD receives the maximum energy dispersed by the grating over the whole spectral range of analysis. This is made possible thanks to an original optical layout : a rotating plane grating and a fixed toroidal mirror which have been coupled to enhance the image at the exit port of the instrument with our Imaging Correction^{PLUS} Technology.

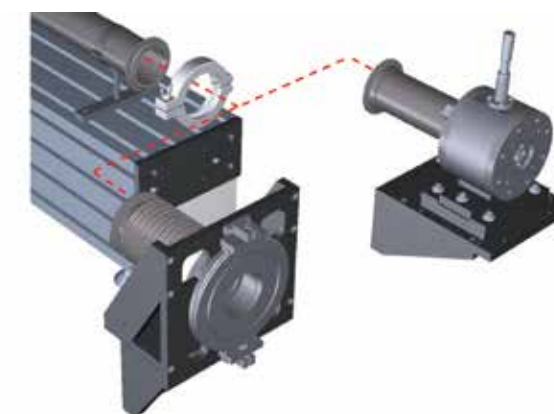
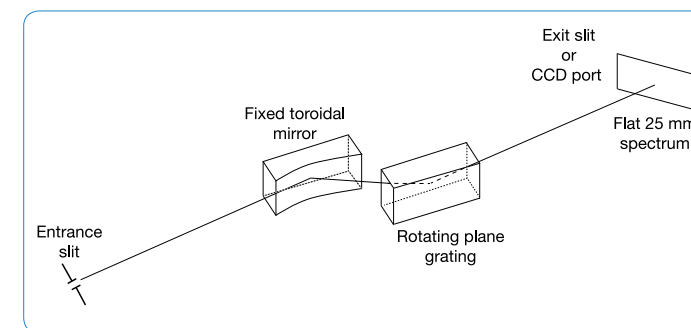

Exit ports of the PGM-PGS are easily interchangeable from slit to CCD

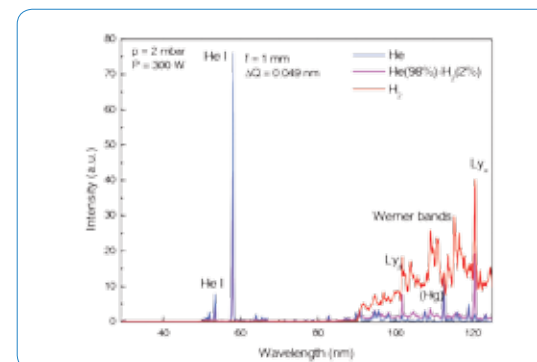

UV emission of H_{α} plasma at different microwave powers. Data courtesy of F. M. Dias (IST, Lisboa) et al. [30th ICPIG, August 28th - September 2nd 2011, Belfast, Northern Ireland, UK]

Gratings available

Model	Gratings		Spectral Range		Exit Dispersion	Resolution** (FWHM in nm)
	Part Number	Density (gr/mm)	Spectrograph Mode Monochromator Mode			
			nm	eV		
PGM200	544 01 010	1800	1 - 25 3.5 - 16	50-1240 78-354	0.4 nm/mm at 3.5 nm, 0.7 nm/mm at 16 nm	0.10 at 13 nm
	544 02 010*	800	2 - 56 6.5 - 35	22 - 620 36 - 190	0.9 nm/mm at 3.5 nm, 1.5 nm/mm at 35 nm	0.14 at 33.5 nm
	544 06 010*	450	3 - 100 10.5 - 63	12 - 400 20 - 120	1.6 nm/mm at 10.5 nm, 2.6 nm/mm at 63 nm	0.15 at 10.5 nm
PGM1000	544 02 130*	1800	2-35 8 - 35	35 - 620 35 - 155	0.09 nm/mm at 8 nm, 0.03 nm/mm at 35 nm	0.008 at 8 nm
	544 01 030*	550	7-126 30 - 125	10 -180 10 - 41	0.3 nm/mm at 30 nm, 0.07 nm/mm at 125 nm	0.03 at 30 nm

* Gratings are available in master or replica version

** using 10 μm x 2 mm slits

Options

- Ultra High Vacuum (UHV, 10^{-9} mbar) version
- Slider for grating change under vacuum

Accessories

- EUV/UV Light Sources
- CCD detectors
- Single channel detection
- Mirror chambers



	PGM200	PGM1000
Optical design	Toroidal mirror and plane VLS grating	
Focal length	251 mm	1090 mm
Aperture	f/16	f/50
Optic coating	Pt or Au	
Deviation angle	165°	156°
Drive	Sine arm	
Vacuum	10 ⁻⁶ mbar (HV version) or 10 ⁻⁹ mbar (UHV version)	
Pumping flange	DN63 LF	
Entrance port	Micrometric slit (10 µm to 2 mm)	
Entrance flange	DN40 KF	
Exit port	Micrometric slit (10 µm to 2 mm) or adjustable CCD port	
Exit flange	DN40KF for slit version, DN100CF for CCD version	
Software	HORIBA Scientific software	
PC Interface	RS232 - USB2	

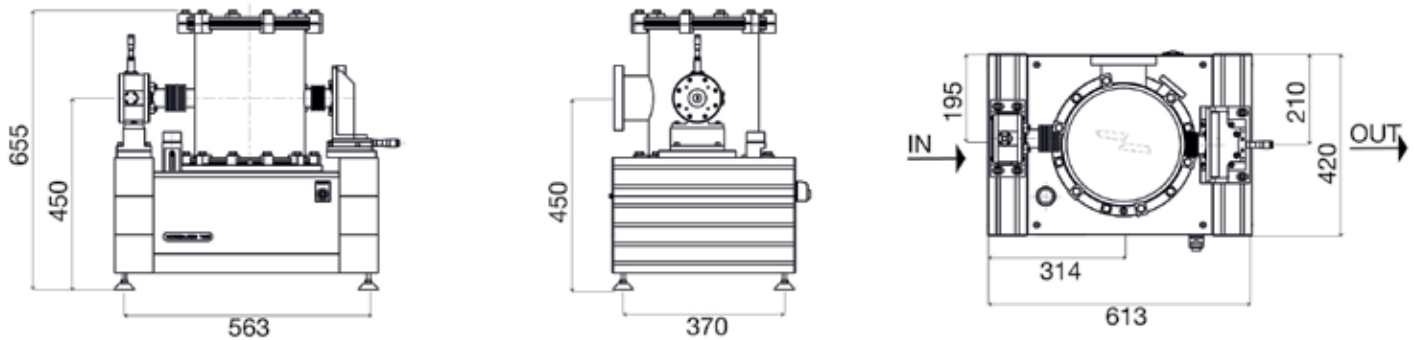

PGM200 in HV version, three gratings on slider, in spectrograph mode

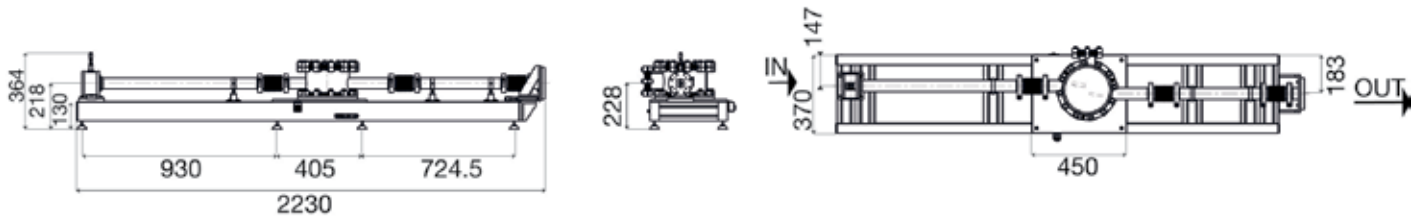

PGM1000 in HV version, in single grating configuration, in spectrograph mode

Dimensions may change depending on the selected options

www.horiba.com/scientific
info.sci@horiba.com

HORIBA

Scientific

- France:** HORIBA Jobin Yvon S.A.S., 16-18 rue du Canal, 91165 Longjumeau cedex - Tel: +33 (0)1 69 74 72 00 - Fax: +33 (0)1 69 09 07 21 - Email: info-sci.fr@horiba.com
- USA:** HORIBA Instruments Inc., 3880 Park Avenue, Edison, NJ 08820-3012 - Toll-free: +1-866-562-4698 - Tel: +1 732 494 8660 - Fax: +1 732 549 5125 - Email: info-sci.us@horiba.com
- Japan:** HORIBA Ltd., Tokyo Branch Office, 2-6, KandaAwaji-cho, Chiyoda-ku, Tokyo 101-0063, Japan - Tel: +81-(0)3 6206 4721 - Fax: +81 (0)3 6206 4730 - Email: info-sci.jp@horiba.com
- Germany:** HORIBA Jobin Yvon GmbH, Hauptstrasse 1, 82008 Unterhaching - Tel: +49 (0)89 4623 17-0 - Fax: +49 (0)89 4623 17-99 - Email: info-sci.de@horiba.com
- Italy:** HORIBA Jobin Yvon Srl., Via Cesare Pavese 21, 20090 Opera (Milano) - Tel: +39 2 5760 3050 - Fax: +39 2 5760 0876 - Email: info-sci.it@horiba.com
- UK:** HORIBA UK Ltd., 2 Dalston Gardens, Stanmore, Middlesex HA7 1BQ - Tel: +44 (0)20 8204 8142 - Fax: +44 (0)20 8204 6142 - Email: info-sci.uk@horiba.com
- China:** HORIBA (China) Trading Co. Ltd., Unit D 1F, Bldg A, Synnex International Park, No. 1068 West Tianshan Road, Shanghai 200335 - Tel: +86 (0)21 6289 6060 - Fax: +86 (0)21 6289 5553 - Email: info-sci.cn@horiba.com
- Brazil:** HORIBA Instruments Brasil Ltda., Rua Presbítero Plínio Alves de Souza, 645, Loteamento Polo Multivias, Bairro Medeiros, Jundiaí / SP, CEP 13.212-181 - Tel: +55 (0)11 2923 5400 - Fax: +55 (0)11 2923 5490 - Email: infocientifica.br@horiba.com
- Other:** Tel: +33 (0)1 69 74 72 00 - Email: info.sci@horiba.com