

HORIBA

navi^h
pH

INSTRUCTION MANUAL

pH METER
F-51

SET



DATA IN

navi^h
pH

ON
OFF

ENTER

CAL
DATA

MODE

CAL

MEAS



DATA OUT

HORIBA, Ltd.

Preface

Thank you for purchasing the F-51 pH meter.

This meter has a large-sized LCD display, which enables to use the varied functions by simple operations, and especially will be convenient to use in laboratory.

Carefully read this manual before using the meter.

HORIBA's Warranty and Responsibility

Your meter is covered by HORIBA's warranty for a period of one (1) year, under normal use. Although unlikely, if any trouble attributable to HORIBA should occur during this period, necessary exchange or repairs shall be conducted by HORIBA, free of charge. The warranty does not cover the following:

- Any trouble or damage attributable to actions or conditions specifically mentioned to be avoided in the operation manuals
- Any trouble or damage attributable to use of the meter in ways or for purposes other than those described in the operation manuals
- If any repairs renovations, disassembly, etc. are performed on this meter by any party other than HORIBA or a party authorized by HORIBA
- Any alteration to the external appearance of this meter attributable to scratches, dirt, etc. occurring through normal use
- Wear and tear to parts, the exchange of accessories, or the use of any parts not specified by HORIBA

HORIBA also shall not be liable for any damages resulting from any malfunctions of this product, any erasure of data, or any other uses of this product.

Unauthorized reprinting or copying of this operation manual

No unauthorized reprinting or copying of all or part of this operation manual is allowed. The utmost care has been used in the preparation of this operation manual. If, however, you have any questions or notice any errors, please contact the HORIBA customer service center printed on the back cover of this operation manual.

Precautions for use

CE Marking



This product is in conformity with the following directives and standards:

Directives: The EMC Directives 89/336/EEC
The Electrical Product Safety Directive 73/23/EEC

Standards: EN61326: 1997+A1:1998
(EMISSION: Class B, IMMUNITY Category: Minimum Requirement)
EN61010-1: 2001

Installation Environment

This product is designed for the following environment.

- Pollution degree 2
- Measurement category

WARNING: Do Not use the equipment for measurements within measurement categories , and .

FCC Warning

This equipment has been tested and found to comply with the limits for a Class A digital device, pursuant to part 15 of the FCC Rules.

These limits are designed to provide reasonable protection against harmful interference when the equipment is operated in a commercial environment. This equipment generates, uses, and can radiate radio frequency energy and, if not installed and used in accordance with the instruction manual, may cause harmful interference to radio communications.

Operation of this equipment in a residential area is likely to cause harmful interference in which case the user will be required to correct the interference at his own expense.

Precautions for use

Type and Definition of Signal Words

For the safety use, the meter is equipped with the Warning Labels to alert every operator and user to the possible risk and danger. Before using understanding each message.

The meaning of signal words are as follows:

- (WARNING)** This indicates an potentially hazardous situation which, if not avoided, will result in death or serious injury.
- (CAUTION)** This indicates a potentially hazardous situation which, if not avoided, may result in minor or moderate injury. It may also be used to alert unsafe practices.

Safety Precautions

For the safety use, be sure to read the following precautions:

 **WARNING:**

Do not use any unspecified AC adapters.
Heat or fire may occur to cause fire or accidents.
Do not disassemble or modify the meter.
Heat or fire may occur to cause fire or accidents.

 **CAUTION:**

Do not use the serial communication or AC adapter in the place that may possibly contact with moisture.
It may cause fire, electric shock, or breakage.
Part of the electrode is made of glass; handle with care not to break it.

Precautions for use

Indication

 **WARNING**

This indicates an potentially hazardous situation which, if not avoided, will result in death or serious injury.

 **CAUTION**

This indicates a potentially hazardous situation which, if not avoided, may result in minor or moderate injury. It may also be used to alert unsafe practices.

— **Note** —

This mark indicates the operation requires a special care and attention.

— **Ref.** —

This mark indicates to which the reader should go for reference.

— **HINT!** —

This mark indicates reference information.

Precautions for use

Cautionary Items

Precautions

Do not give physical shock to the meter like dropping or hitting. Avoid water or solution from being contact with the meter body. Water or solution, if contacts with the meter, may cause the meter breakage.

To remove the dirt on the meter, wipe it off with dry and soft cloth as silicone cloth. (Do not use water)

Do not pour water to the electrode and/or the connector part of the meter body. Do not touch with dirty or wet hands.

The electrode and/or the connector part of the meter body requires high insulation. Contact with water or with dirty hands may bring defective insulation, to cause indication fluctuation or erroneous measurement values. Sometimes the electrode itself may be damaged to an unrecoverable level.

Perform the key operation by the fingers, not by the hard object like metal stick or rod.

To disconnect the electrode cable or interface cable, pull them out with holding the connector part. Do not pull the cable part; it may cause a breakage.

Do not use any unspecified batteries ; it may cause a breakage.

Location of use and storage

The place which room temperature is at 0 to 45

The place which relative humidity is under 80% and free from condensation

Do not use or store the meter at;

The place of much dust

The place with strong vibration

The place with direct sunlight

The place with corrosive gas generation

The place near from an air-conditioner

The place with direct wind

Move and Transportation of the meter

To transport the meter, use the packaging box at the delivery. Transportation by any unspecified packing methods may cause a breakage.

Disposal

Standard solution used for the calibration must be under neutralization before the disposal. As for the disposal of the meter, treat it as an industrial waste.

TABLE OF CONTENTS

Chapter 1	Overview of pH Meter	1
1.1	Package contents	1
1.2	Functions	2
1.3	Explanation of part names.....	4
1.3.1	Meter body	4
1.3.2	Display	4
1.4	Operation keys.....	6
1.5	Assembling the electrode stand	7
1.6	Connecting the electrodes	8
1.7	Inserting/replacing the dry-cell batteries	10
1.8	Connecting the AC adapter	11
Chapter 2	Taking Measurements	13
2.1	Turning the meter ON/OFF	13
2.2	Settings required before measurement.....	13
2.3	Measurement modes.....	14
2.4	Selecting the measurement modes	15
2.5	Measuring pH.....	16
2.6	Measuring ORP.....	25
Chapter 3	Functions	29
3.1	Data memory function.....	29
3.2	Calibration history display	31
3.3	Displaying and setting the clock.....	33
3.4	Setting modes.....	34
3.4.1	Entering the Setting mode	34
3.4.2	pH standard solution setting	35
3.4.3	Temperature compensation setting	38
3.4.4	pH calibration frequency setting	39
3.4.5	Sample ID# setting	39
3.4.6	Maintenance mode	40
Chapter 4	RS-232C communications	49
4.1	Cautions before use	49
4.2	Command list.....	50
4.3	On-line operation commands.....	52
4.4	Data request commands and responses	55

TABLE OF CONTENTS

4.5	Communication example using the HyperTerminal...	65
Chapter 5	Printer	67
5.1	Connecting the printer	67
5.2	Printer setting	68
5.3	Printer output timing	69
5.4	Printing format.....	70
5.4.1	When the ENTER key is pressed in the Measurement mode	70
5.4.2	When the manual data memory is performed in the Measurement mode	71
5.4.3	When the ENTER key is pressed in the Data Memory Call screen	71
5.4.4	When calibration or check is performed in the Calibration mode ..	71
5.4.5	When the ENTER key is pressed in the calibration history display	72
5.4.6	Test printing format in the Maintenance mode	72
Chapter 6	Maintenance and Troubleshooting	73
6.1	pH (ORP) electrode maintenance	73
6.2	Troubleshooting	77
6.2.1	Error message chart	77
6.2.2	More troubleshooting	83
Chapter 7	Reference	89
7.1	pH measurement	89
7.2	mV (oxidation-reduction potential [ORP]) measurement	94
7.3	Specifications	99
7.4	Default settings	100
7.5	Operation flowcharts	101
7.6	Pin layout of special cables	102
7.6.1	RS-232C communications cable	102
7.6.2	Cable for CITIZEN printer	102
7.6.3	Cable for SEIKO printer	102
7.7	Spare and optional parts	103
7.7.1	Spare parts list	103
7.7.2	Optional parts	105

Chapter 1 Overview of pH Meter

This chapter explains the part names, how to connect the electrodes, how to replace the batteries, and precautions when using the meter.

1.1 Package contents

The following items are shipped with each HORIBA pH meter.

Name	Q'ty
Meter	1
Stand	1
Dry-cell batteries	4
Operation manual	1

Note

To take measurements, you will need electrode(s). Refer to "7.7 Spare and optional parts" page 103 when purchasing the electrode(s).

1.2 Functions

The pH meter features the following functions.

Measurement items

Items	Required electrode/standard solution
pH	pH electrode pH standard solution
ORP (mV)	ORP electrode
Temperature	-

Functions

An overview of the functions found on the pH meter is shown below.

Function	Explanation	Page No.
Data memory	Enables a maximum of 300 items to be stored.	page 29
pH repeatability check	Displays the difference between the calibration value and measured value after calibration.	page 22
pH calibration history display	Displays the date of calibration, asymmetrical potential and sensitivity.	page 31
Relative mV display	Displays mV when the measured potential is shifted to 0 mV.	page 27
Clock	The date and time are displayed.	page 33
Auto Power OFF	Turns ON/OFF setting that automatically turns power OFF if no keys are touched for 30 minutes.	page 44
RS-232C communications	Enables communication with a computer, using RS-232C.	page 49
Printer output	Prints the contents of the memory (printer sold separately).	page 67
Commercial power supply	Enables the use of commercial power, using an AC adapter (sold separately).	page 67

Setting Items

Function	Explanation	Page No.
pH standard solution setting	Enables standard solution used for calibration to be changed to NIST and US specifications settings.	page 35
pH temperature compensation	Enables temperature compensation to be conducted in pH Measurement mode, either manually or using a temperature sensor.	page 38
pH calibration frequency setting	Sets the next calibration time according to the number of measurements made after calibration.	page 39
Sample ID	ID No. of the sample	page 39

Note

RS-232C communications and the printer cannot be used simultaneously.

Functions in Maintenance mode

Name	Explanation	Page No.
LCD check	Enables check for whether or not all LCD segments are displayed.	page 41
Battery voltage check	Enables simple check of battery voltage.	page 42
Temperature display calibration	Adjusts the display of the temperature sensor to the actual temperature.	page 43
Auto Power OFF	Sets the function that automatically turns the power OFF if no keys are touched 30 minutes.	page 44
Remaining data memory	Displays the remaining memory.	page 45
Data memory clear	Deletes data in memory.	page 45
Initializing settings	Initializes all settings to the default values.	page 46
Printing test	Conducts a printing test.	page 47

1.3 Explanation of part names

The pH meter has the following parts:



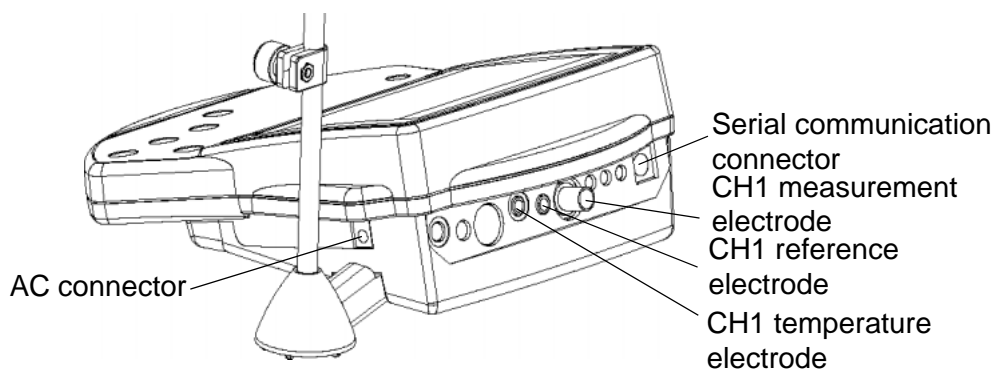



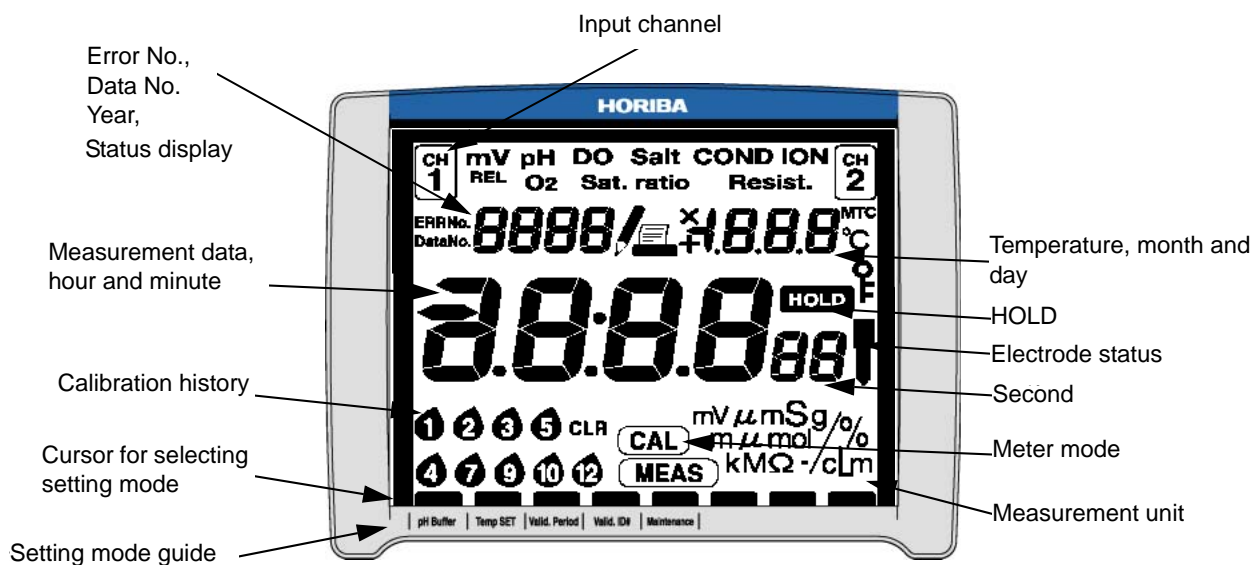





1.3.1 Meter body



1.3.2 Display











Part name	Display	Contents
Input channel		Input channel 1
Measurement item	mV	Displayed when measuring mV
	pH	Displayed when measuring pH
	REL	Displayed in mV Measurement mode, when relative mV is being set

Part name	Display	Contents
Error No.	ERRNo.	Displayed when an error is generated
Data No.	DataNo.	Displayed when data number has been set.
Status display		Shows error number and data number.
		Displayed when the serial communication is active.
		Displayed when temperature compensation function or automatic temperature compensation has been set.
		Displayed when NIST standard is selected at pH standard solution.
		Displayed when US standard is selected at pH standard solution.
		Displayed when CUST standard is selected at pH standard solution.
-		Displayed during data memory function (for 3 sec.). Displayed while data in memory is being called up and when manual data memory is being called up.
-		Displayed when a printer is connected. (Sometimes displayed when a computer is connected depending on the computer.)
-	MTC	Displayed during manual temperature compensation. Not displayed during automatic temperature compensation.
HOLD		Displayed while the data is held (HOLD status). Blinks during measurement or calibration.
Electrode status		(Only in pH Measurement mode) Not displayed: Normal Blinking: Cleaning is needed. Constant display: Replacement time is approaching.
		Calibration history display: Displayed after calibration for pH electrode as calibration history.
	CLR	When no calibration data is available: Displayed when no calibration has been performed for pH electrode.
Meter mode		Displayed when in Measurement mode.
		Displayed when in Calibration mode.

1.4 Operation keys

This section describes the functions of the keys.

	Name	Description
	MEAS key	Returns to the Measurement mode. Starts measurement.
	MODE key	Selects measurement item.
	SET key	Selects setting item.
	CAL key	Enters the Calibration mode. Starts calibration.
	UP key	Executes the data memory function. Increases numerical values.
	ENTER key	Establishes the setting.
	DOWN key	Calls up data memory. Decreases numerical values.
	CAL DATA key	Calls up calibration data.
	ON/OFF key	Turns ON/OFF the power. This key takes effect only after pressed for one second to prevent accidental operation.

Note

The automatic power-off function is a default setting for this pH meter. The power is automatically turned OFF if no operation is performed after a period of approximately 30 minutes.

1.5 Assembling the electrode stand

1. Mount the electrode stand on the rear of the meter as shown in the figure below.

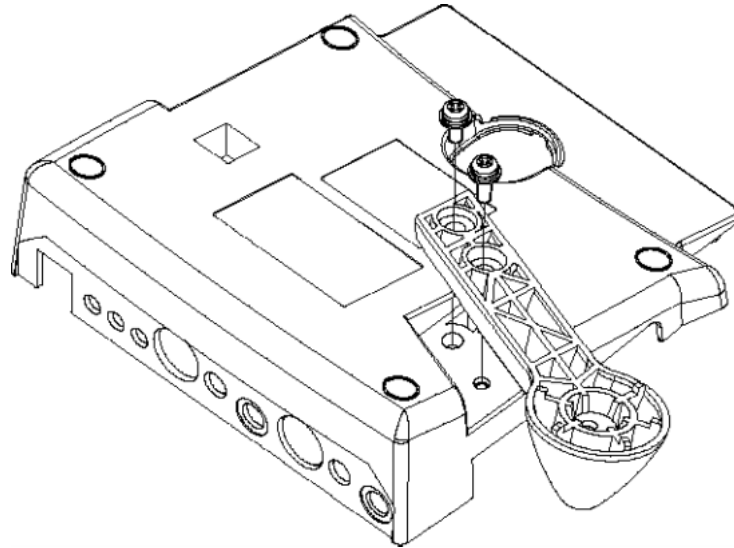

1.6 Connecting the electrodes

Connect the electrodes to the pH meter using the following procedure:

Note

- Do not allow any water to come into contact with the connector.
- Do not touch the connector with uncleaned hands.
- Hold the metal portion when turning the electrode connector.

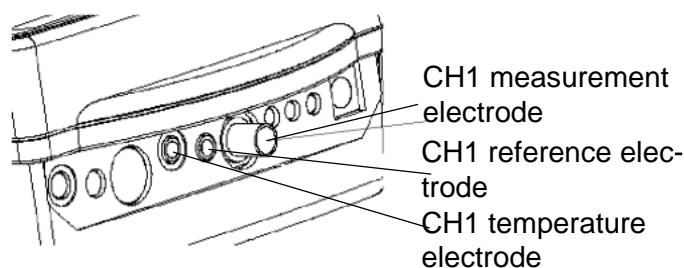

Electrode connector

1. Insert the electrode connector, making sure to align the connector grooves with the pins in the connector port on the main unit.

Do not push the electrode connector with undue force when the pins are not properly aligned.

CH1 measurement electrode

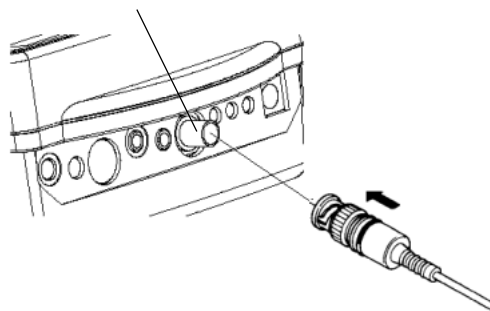

2. Push the electrode connector into the connector port while turning it clockwise, following the grooves.

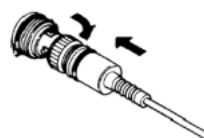

3. Push the connector cover over the connector, being careful to push it straight on without turning it.

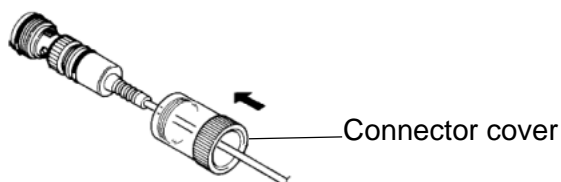

Temperature connector

1. Insert the temperature connector into the jack on the main unit of the pH meter.

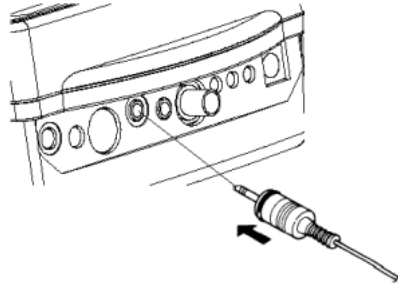

Note

When the temperature electrode is not connected (or is connected improperly), the automatic temperature compensation (ATC) will be 25°C .

1.7 Inserting/replacing the dry-cell batteries

The dry-cell batteries are not placed in the pH meter before shipping. To insert the batteries, follow the procedure below.

Note that if “ERR 2” appears on the display while using the pH meter, it indicates that the charge of the dry-cell batteries is running low. When this occurs, replace the batteries promptly.

Dry-cell battery type: AA alkaline

Note

- Insert the battery, paying attention to the orientation of the battery poles (“+” and “-”).
- Removing the batteries will erase the clock data. To save the clock data, remove and replace the batteries while the meter is connected to the AC adapter (sold separately).
- Replace the batteries only after turning the power OFF. Any saved data will not be lost.
- When opening and closing the battery cover, be careful that no water gets inside the meter.

Note

The life of batteries included with the pH meter may be short because the batteries were used for the operation check before shipping.

To insert/replace the batteries

1. Remove the battery cover on the bottom of the meter and set the dry-cell batteries (4 pcs.) in the correct direction.

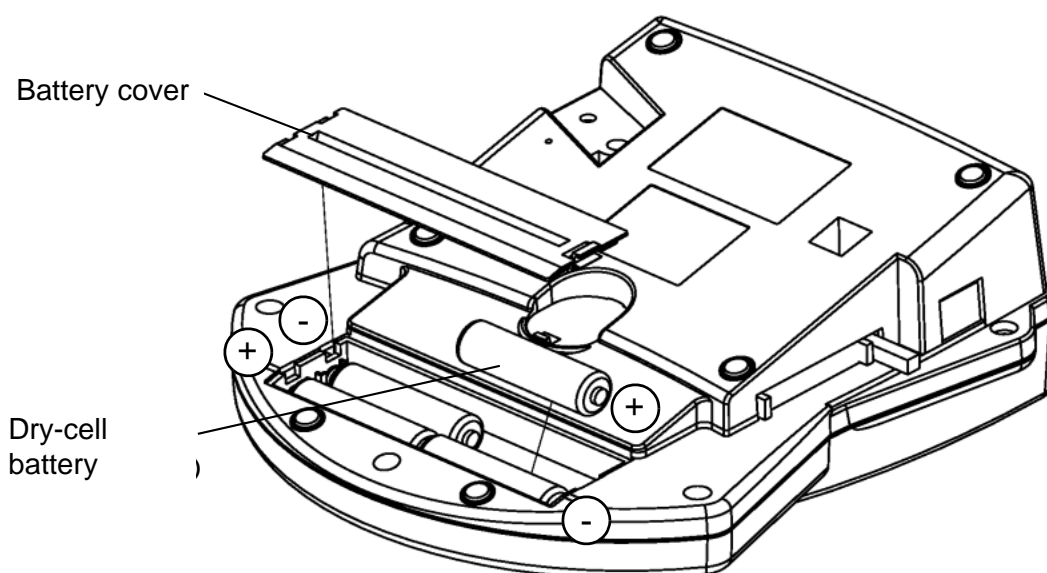

Battery life

The life of alkaline batteries during continuous use is approx. 500 hours.
The life of manganese batteries is approx. 250 hours.

1.8 Connecting the AC adapter

When using the meter with an AC power supply, use the designated AC adapter (option)

AC adapter specifications

Supply voltage range	100 - 200 V AC
Frequency range	50/60 Hz
Current rating	Max 370 mA
Class2 Power supply	
Equipment protected by double insulation	
Indoor use only	
Supply voltage fluctuations allowed up to $\pm 10\%$	

1. Connect the connector of the AC adapter to AC adapter connecting port on the side of the meter.

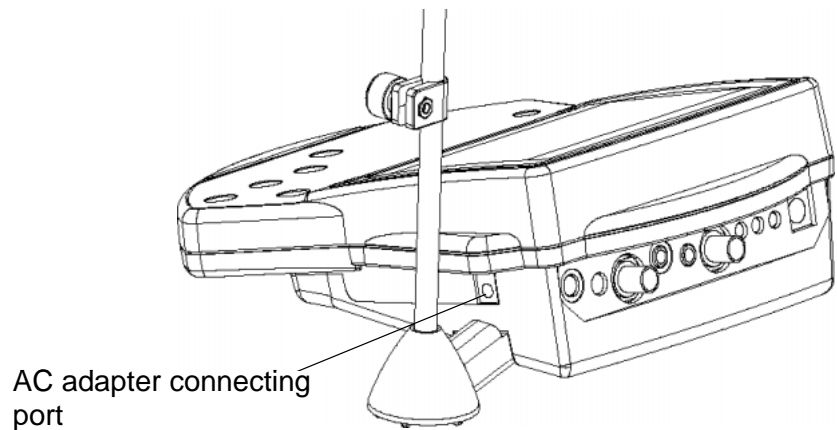

Chapter 2 Taking Measurements

This chapter explains how to take basic measurements.

2.1 Turning the meter ON/OFF

Pressing the ON/OFF key turns the power on/off. The ON/OFF key functions when it is pressed continuously for about one second to protect against accidental operation.

2.2 Settings required before measurement

The built-in clock allows you to record the date of calibration and data memory storage. When using the meter for the first time, be sure to set this clock.

— **Ref.** —
“ 3.3 Displaying and setting the clock ” page 33

2.3 Measurement modes

The meters have an Instantaneous Value Measurement mode and an Auto Hold Measurement mode for all components of the solution being measured.

Instantaneous Value Measurement mode

Instantaneous Value Measurement mode continuously displays the measurements, as they take place. The meters perform instantaneous value measurement as the default measurement mode when the power is first turned ON and when the auto hold measurement is cancelled or cleared.

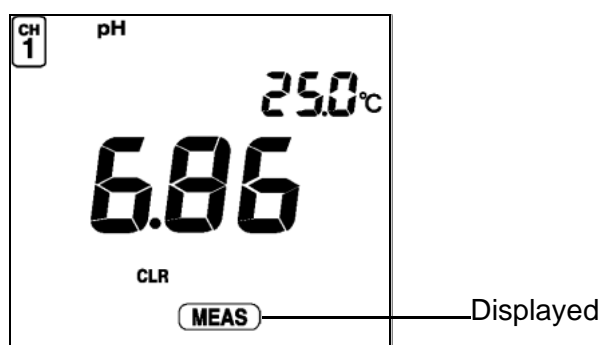

Auto Hold Measurement mode

Auto Hold Measurement mode maintains the display of the value measured when the meter automatically judges that the measured value has stabilized. Press the MEAS key when in the Instantaneous Value Measurement mode to make "HOLD" blink on the display. When the measured value becomes stable, "HOLD" will stop blinking and remains displayed, and the measured value will remain displayed. To clear the hold status or "stabilized" value (when "HOLD" is blinking), press the MEAS key.

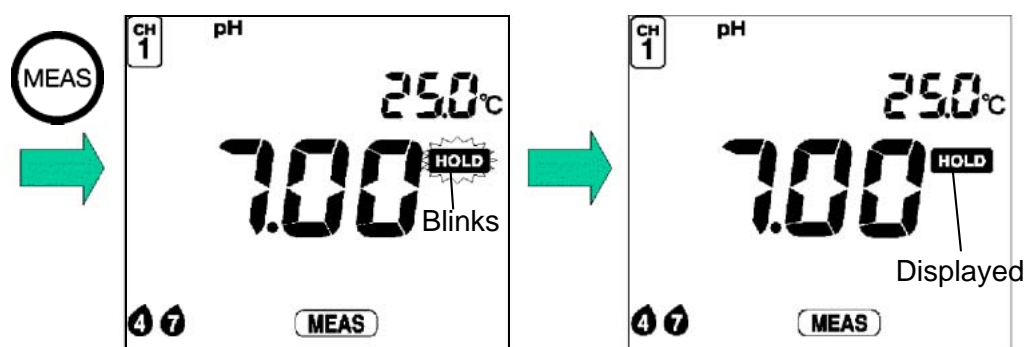

Criteria for judging stability

- pH, ORP measurement : Within ± 1 mV variance in potential after 10 seconds
- Temperature measurement : Within ± 2 °C variance after 10 seconds

2.4 Selecting the measurement modes

Pressing the MODE key changes the measurement mode. The last measurement mode item is the clock display. Pressing the MODE key once more returns the display to the first measurement mode.

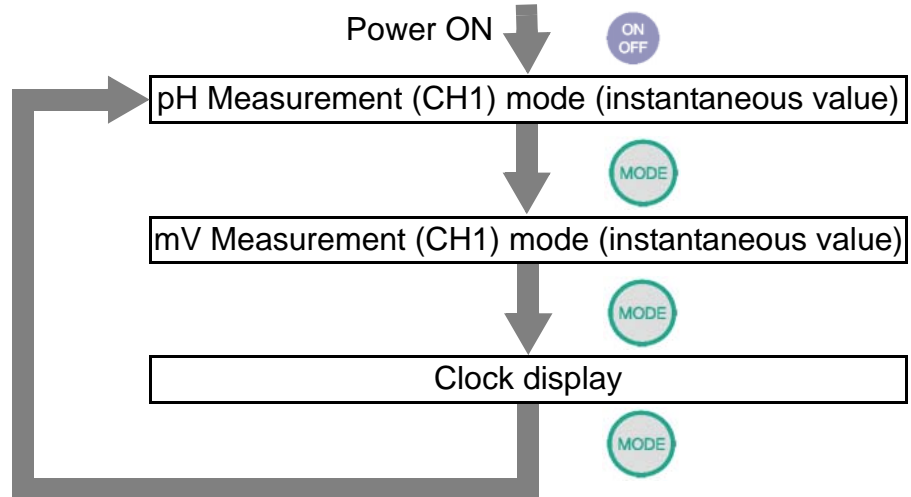

2.5 Measuring pH

The following shows the operational flow for pH measurement.

Measuring pH: basic operational flow

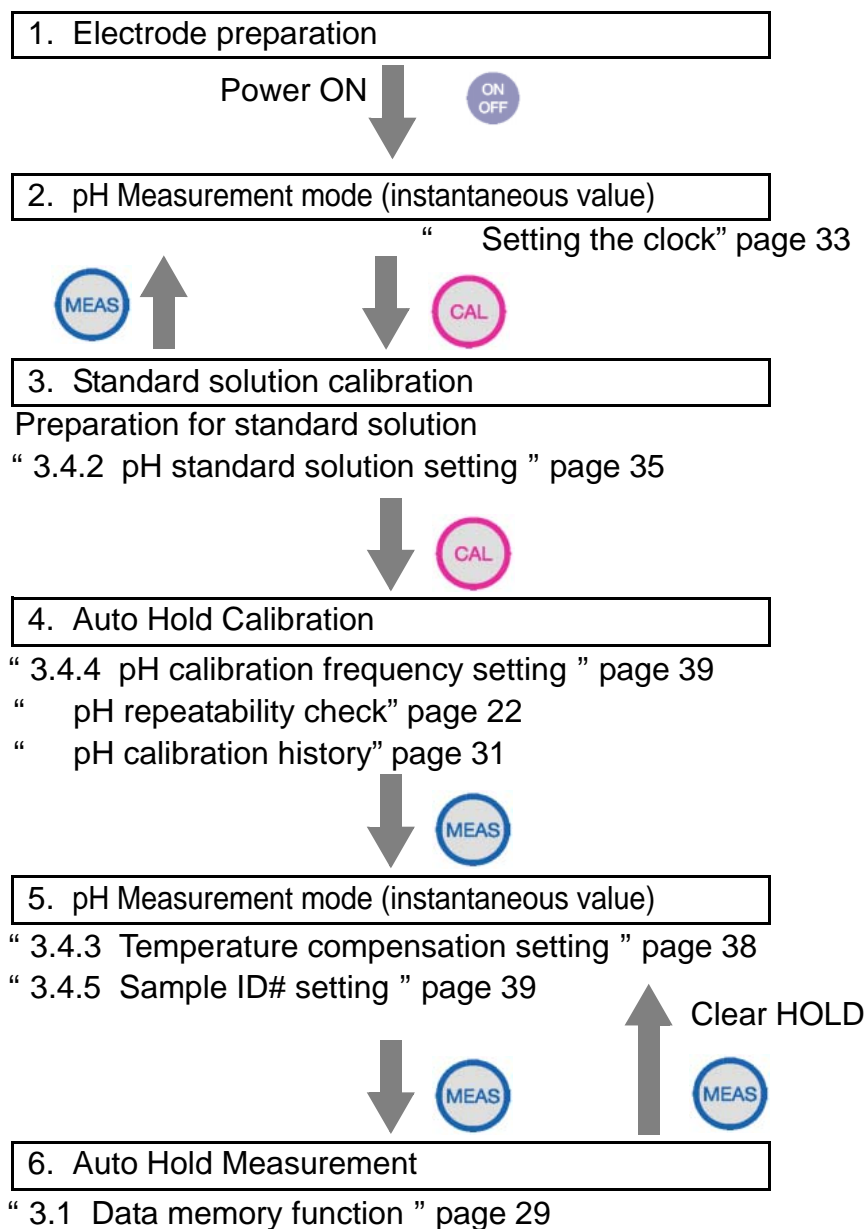

Electrode preparation

Refer to the electrode instruction manual and make sure you have the necessary electrode(s).

Plastic-body pH electrode: 9621-10D

Glass-body pH electrode: 9611-10D

pH (micro) electrode: 9669-10D

pH (sleeve) electrode: 9677-10D

Chemical solution



Caution

The liquid inside the electrode is highly concentrated potassium chloride (3.33 mol/L KCl). If the internal solution in the electrode comes in contact with your hands or skin, wash immediately with water. If the internal solution comes in contact with your eyes, flush immediately with large amounts of water and seek treatment by a physician.

Glass fragments



Caution

Glass fragments can cause injury. The outer tube of the electrode and the tip of the electrode are made of glass. Use care not to break them.

Entering the pH Measurement mode

1. Press the ON/OFF key.

The instantaneous value measurement screen will appear.

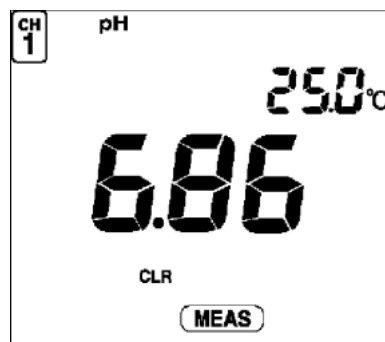

Standard solution calibration

Perform a one-point calibration for making simple pH measurements; for more accurate measurements, perform at least a two-point calibration.

Note

Up to three points can be used for calibration. If you perform calibration for a fourth points, "ERR06 Calibration point error" is displayed.

Standard solutions for calibration are defaulted to pH 2, pH 4, pH 7, pH 9, and pH 12.

Ref.

" 3.4.2 pH standard solution setting " page 35

This section will explain how to conduct a two-point calibration using pH 7 and pH 4 standard solutions.

Calibration procedure

1. Press the CAL key while in the pH Measurement mode.
The meter enters the Calibration mode and >CAL< is displayed.

Displayed item differs depending on the standard solution setting.

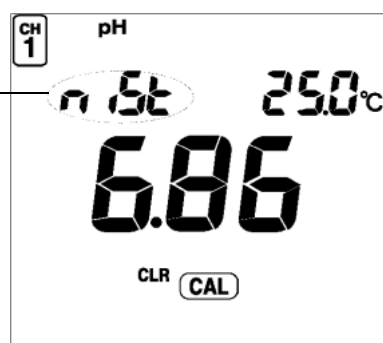

Note

The mode cannot be changed during Auto Hold calibration (while "HOLD" is blinking or continually displayed).

2. Wash the tip of the electrode well with pure (de-ionized) water, and then wipe with filter paper or tissue paper.

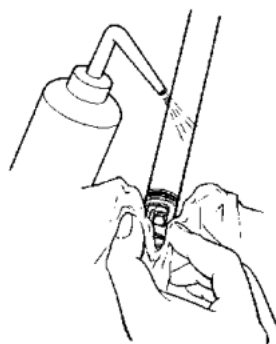

3. Open the internal solution filler port.
Leave the port open while calibration is taking place.

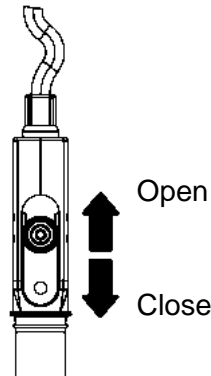

Calibration at first point

1. Immerse the tip of the electrode in a beaker containing pH 7 standard solution.
Immerse the pH electrode in the sample at least three centimeters.

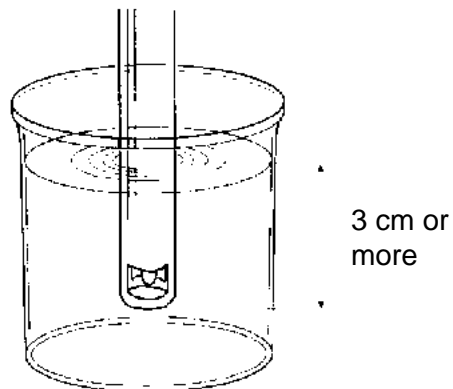

2. Press the CAL key to start calibration.

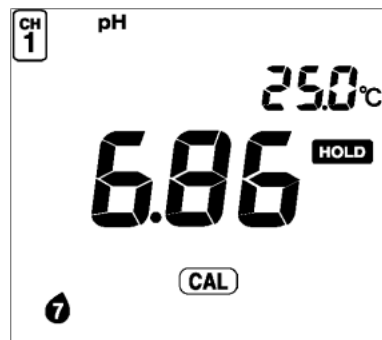

The measured value will be displayed, and “ HOLD ” will blink until the reading stabilizes.

When the value stabilizes, “ HOLD ” will stop blinking and the calibrated value will be displayed.

The **7** bottle mark will be displayed, indicating that calibration was conducted with pH7 standard solution

Note

To stop the calibration:

Press the CAL key while the HOLD mark is blinking.

To establish the calibration:

Press the ENTER key while the HOLD mark is blinking.

To redo the calibration:

Press the CAL key after the HOLD mark is displayed.

Calibration at second point

1. Wash the electrode well again with pure (de-ionized) water, and then wipe with filter paper or tissue paper.
2. Immerse the tip of the electrode in a beaker containing pH 4 standard solution.
3. Press the CAL key to start calibration.

The measured value will be displayed, and “ HOLD ” will blink until the reading stabilizes.

When the value stabilizes, “ HOLD ” will stop blinking and the calibrated value will be displayed.

The **4** bottle mark will be displayed, indicating that calibration was conducted with pH 4 standard solution.

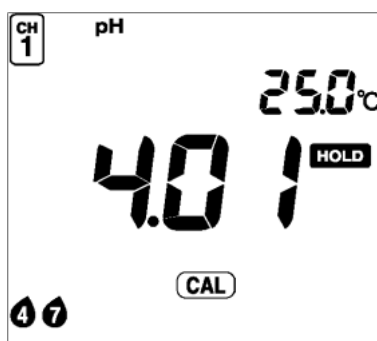

4. Press the MEAS key to return to the pH Measurement screen.

Note



While calibrations are being in the Calibration mode, redoing a calibration only updates the calibration data for the pertinent standard solution. If a calibration is redone after the pH meter is returned to the Measurement mode, however, the calibration is conducted on the initial status of the meter; i.e., all the previous calibration data is cleared.

Note

The example of calibration at second point has explained the calibration process using the order from pH 7 to pH 4. However, the calibration order of the standard solutions can be arbitrarily chosen.

Electrode status

You can check the status of the electrode after calibration

Item	Description
 ,ERR Not displayed	The electrode is in good condition. Electrode sensitivity is from 93% to 100%.
 Blinking	Electrode sensitivity has dropped to the level of 90% to 93%. <ul style="list-style-type: none"> • Make sure that you are using the right standard solution. • Clean the electrode. “ Washing the electrodes” page 76
 Displayed	Electrode sensitivity has dropped to the level of 85% to 90%. “ ERR 05 Electrode sensitivity error (pH)” page 80
ERR No.04	Asymmetrical potential error “ ERR 04 Asymmetric potential error” page 80
ERR No.05	Sensitivity error “ ERR 05 Electrode sensitivity error (pH) ” page 80

pH repeatability check

The repeatability of the calibration can be checked if the calibration has been performed with a NIST, US, pH 7 standard solution.

The repeatability check is operable only once after calibration.

1. After calibration and while still in the Calibration mode, immerse the electrode in pH 7 standard solution and press the ENTER key. The difference between the calibrated value and measured value is displayed.

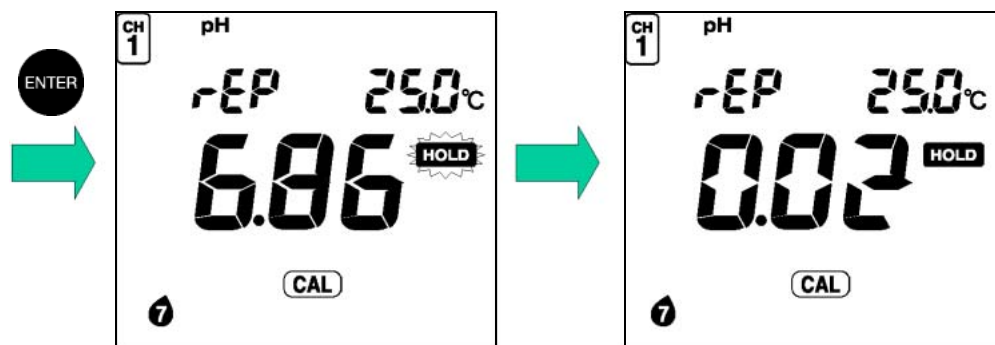

Note

There is no problem in measurement accuracy if the difference is within ± 0.05 pH.

Clearing calibrated values

To clear all the calibrated values:

1. Set the pH meter to the Calibration mode.
2. Press the CAL key while holding the SET key down.

Measuring pH

1. Wash the tip of electrode well with pure (de-ionized) water, and then wipe with filter paper or tissue paper.

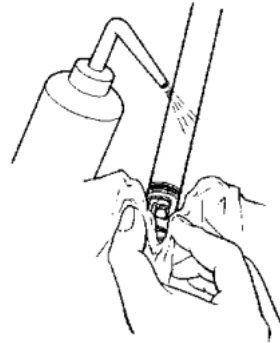

2. Open the internal solution filler port.
Leave the port open while measurement is taking place.

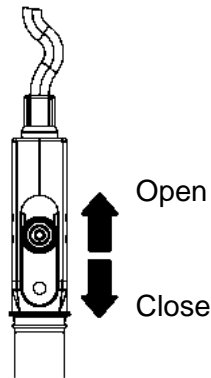

3. Immerse the electrode all the way in the sample.
Immerse the pH electrode in the sample at least three centimeters.

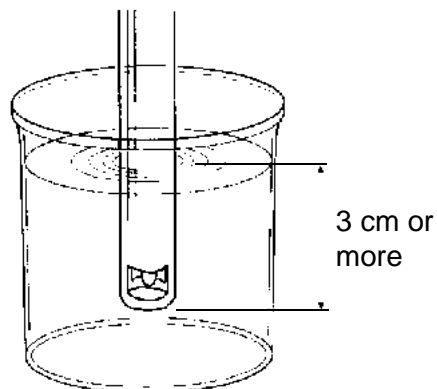

4. Press the MEAS key while in the Instantaneous Value Measurement screen.

“ HOLD ” will blink until the reading stabilizes.

When the indicated value stabilizes, “ HOLD ” will stop blinking and will be displayed. The indicated value will remain displayed continually.

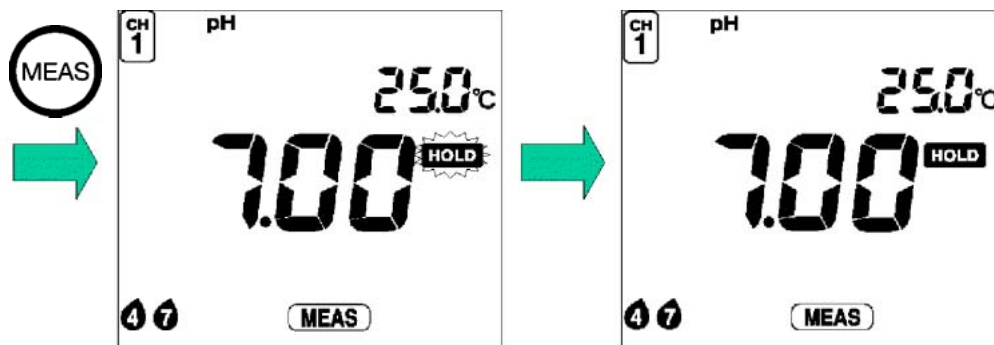

Ref.

Refer to the “ Criteria for judging stability” page 14 for the criteria for judging the stability of the readout.

Note

When measurement data is held using Instantaneous Value Measurement or Auto Hold Measurement, you can store that data in the memory by pressing the key. See “ 3.1 Data memory function ” page 29

2.6 Measuring ORP

The following shows the operational flow for ORP measurement.

ORP measurement operational flow

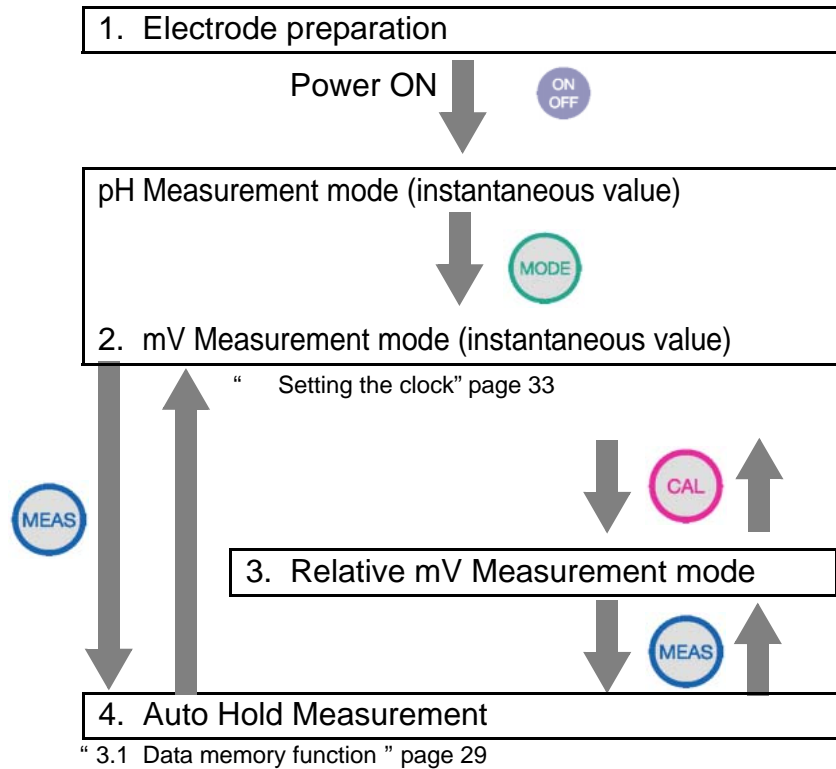

Electrode preparation

To measure the ORP (oxidation-reduction potential) of a solution, use a platinum electrode especially designed for that purpose.

Note

mV measurement with the pH electrode shows the potential of the electrode. This measurement is useful for checking samples and the performance of the electrode.

Refer to the electrode instruction manual and make sure you have the correct electrode.

Measuring ORP

1. Immerse the electrode all the way in the sample solution.

Note

For accurate measurements, be sure to immerse the electrode in the sample at least three centimeters.

2. Press the MODE key, once.

The ORP Instantaneous Value Measurement screen will appear.

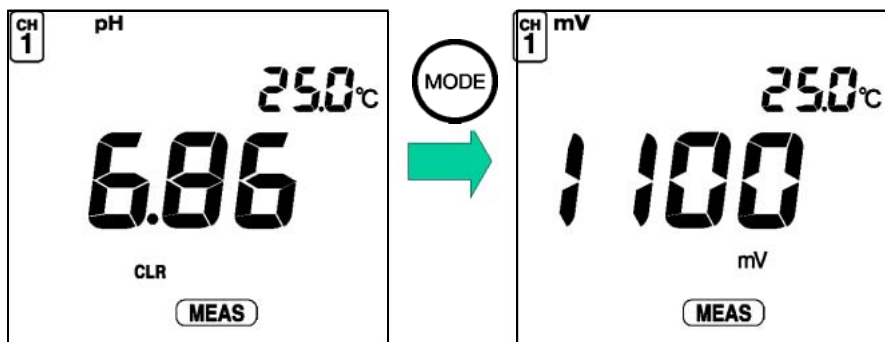

3. Press the MEAS key while the Instantaneous Value Measurement screen is displayed.

“HOLD” will blink on the display until the reading stabilizes.

When the value stabilizes, “HOLD” will stop blinking and will be displayed continually. The indicated value will remain displayed.

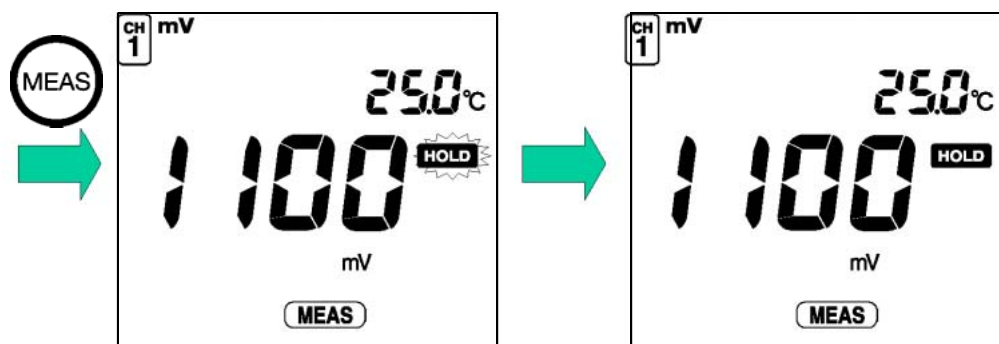

Ref.

Refer to the “Criteria for judging stability” page 14 for the criteria for judging the stability of the readout.

Note

If the data is to be saved to the memory, press the **MEMO** key. See “3.1 Data memory function” page 29.

Measuring relative mV

This pH meter can measure relative potential difference by shifting the measured potential to zero. (A potential without compensation is called absolute mV.)

1. Press the CAL key in the mV Instantaneous Value Measurement mode.

REL is displayed under mV and the current reading value becomes the offset potential used for compensation, and the meter will display the relative mV instantaneous value.

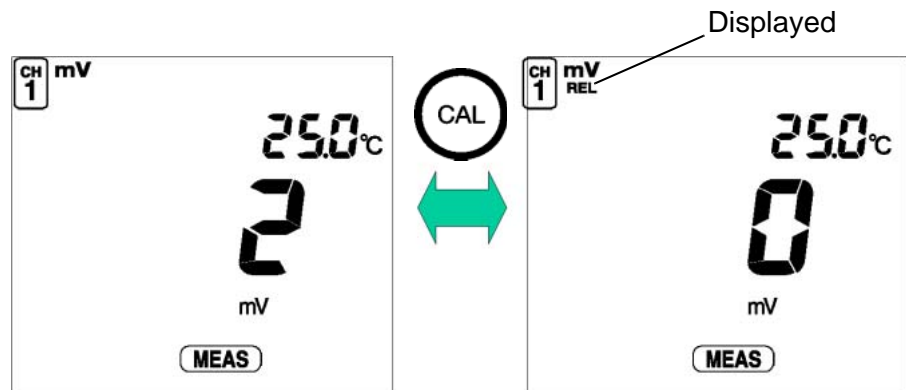

2. Press the CAL key again.

The meter returns to the absolute mV display.

Note

Potential compensation during relative mV Measurement does not affect the displayed pH value.

Ref.

For how to check the status of the ORP electrode, refer to “ ORP standard solution” page 97.

Chapter 3 Functions

This chapter describes the various functions of the pH meter.

3.1 Data memory function

The measured data can be stored manually.

Data memory

In all measurement modes, you can store data when the instantaneous value is measured or the measured value is held (HOLD status) during the Auto HOLD measurement by pressing the **MEMO** key.

The measurement reading is stored along with the temperature, data, HOLD value/instantaneous value, ATC/MTC, calibration point (pH), and sample ID at the time the measurement was taken.

After the data number is displayed, the screen returns to the Instantaneous Value Measurement mode. Up to 300 items of data can be stored in the memory. If the number of data items exceeds the maximum limit, ERR 10 is displayed and no more data can be stored.

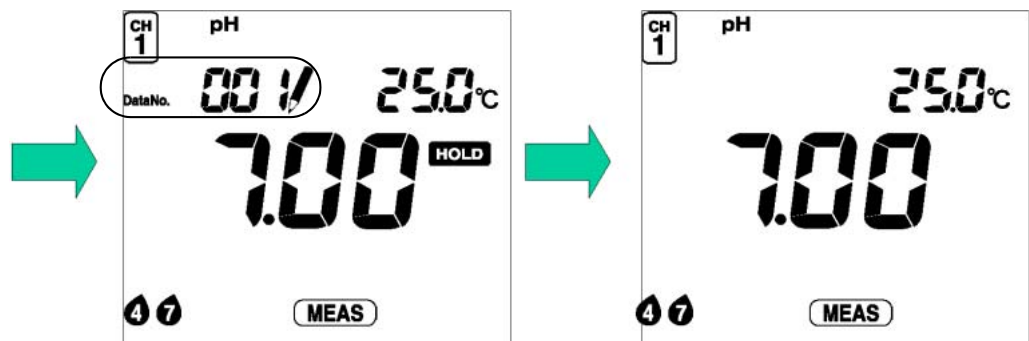

Note

Data cannot be stored unless the value has stabilized or in the CAL mode.

When the data is stored, an ID number for that specific measurement can be registered (see page 39).

Calling up memory data

1. Press the **MEMO** key in the Measurement mode to load measurement data.

When there is no memory data, the **MEMO** key does not function.

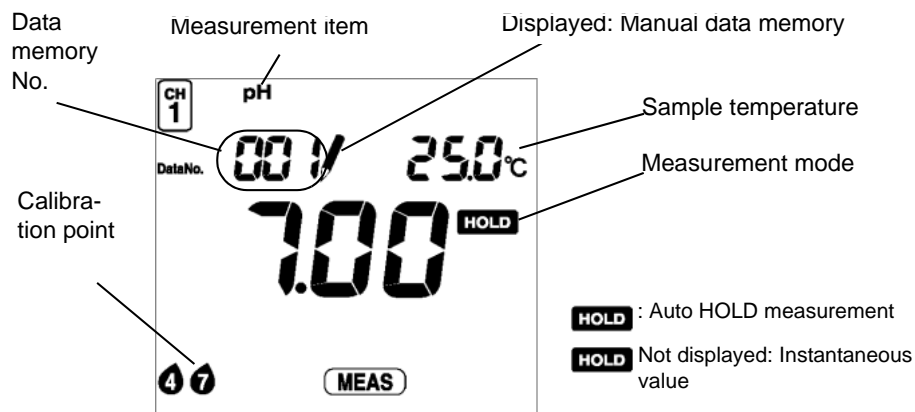

Select and load the desired memory data item using the **MEMO** and **MEMO** keys. The displayed number returns to 0 after 300, the maximum number.

2. Press the **MODE** key to display the data and time.

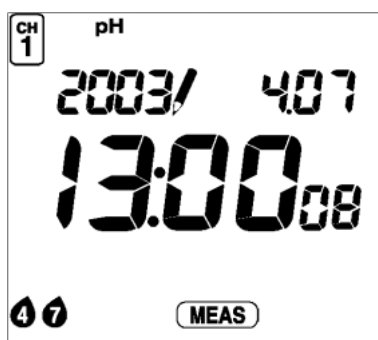

Select the desired data item using the **MEMO** and **MEMO** keys.

3. Press the **MODE** key to display the ID.

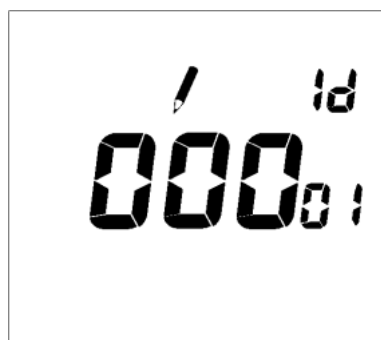

Select the desired data item using the **MEMO** and **MEMO** keys.

Note

If an error occurs while a data number is being displayed, the error number will NOT be displayed. When using a printer (sold separately), press the ENTER key while in the DATA OUT mode to print the data.

3.2 Calibration history display

The latest calibration and repeatability check information can be checked.

— **Ref.** —

Refer to " pH repeatability check" page 22 .

pH calibration history

1. Press the CAL DATA key in the pH Measurement mode.

The latest calibration date is displayed.

Date and time of calibration

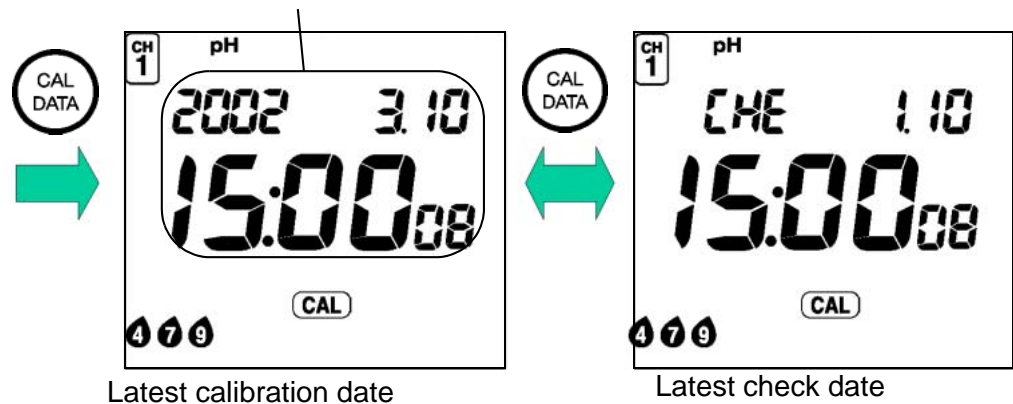

2. Pressing the CAL DATA key toggles between the latest calibration date and the latest check date.

— **Note** —

The latest check date is not displayed if no repeatability check has been performed.

Latest calibration data

1. Press the key with latest calibration date displayed.

The asymmetrical potential will be displayed.

Example of 3-point calibration

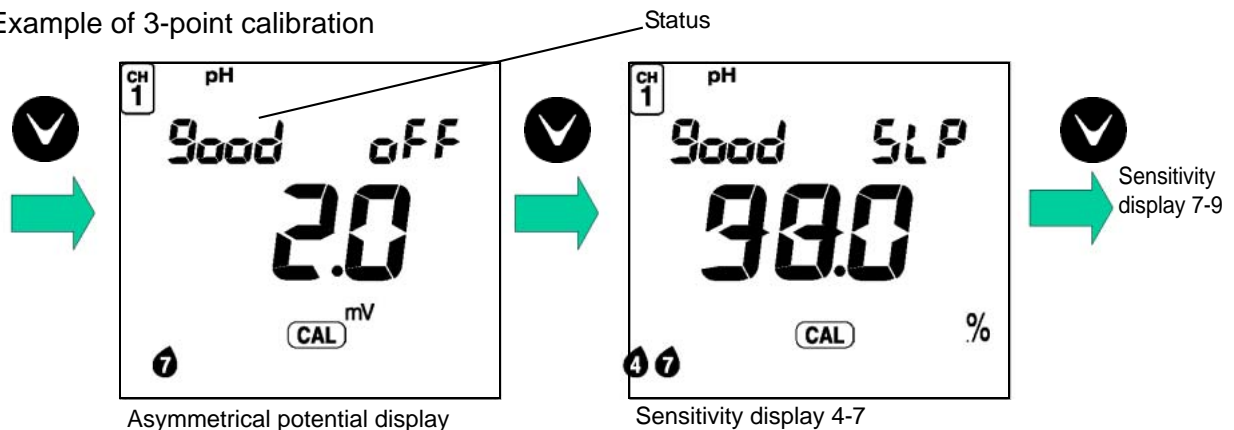

2. Press the  key to show sensitivity display.

Status display

Good When the meter is in a good condition

WASH When the electrode needs washing

Bad When the electrode is old and is going bad

Ref.

Refer to "ERR 04 Asymmetric potential error" page 80 .

pH latest check data

1. Press the  key with latest check date displayed.

The repeatability display will appear.

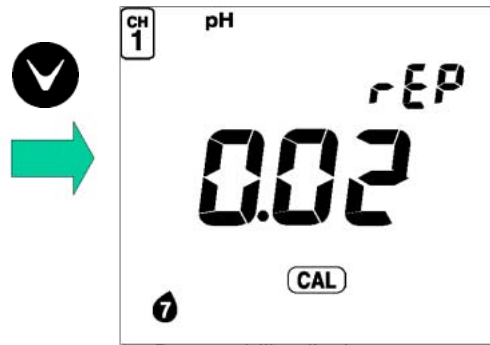

Repeatability display

3.3 Displaying and setting the clock

The clock needs to be when the meter is used for the first time or after replacing the batteries.

Displaying the clock

Press the MODE key in the Measurement mode to display the clock.

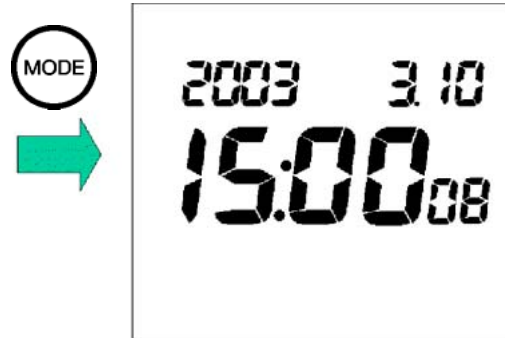

Setting the clock

1. Press the CAL key when the Clock Display screen is displayed to show the Setting screen for the clock.



2. Switch the display to year, month, day, hour, minute, and second using the ENTER key. Set a numerical value using the and keys.

Note

Set the seconds to "00" sec. Pressing the ENTER key sets it to "00".

3. After setting the clock, press the ENTER key to update the setting. Pressing the CAL key at this time returns you to the Clock Display screen without changing the current setting.
4. Press the MODE key to return to the Measurement mode.

3.4 Setting modes

Selecting the Setting mode expands the uses of the meter.

3.4.1 Entering the Setting mode

1. Press the SET key in the Measurement mode.
The Setting Mode Selection cursor appears at the bottom of the screen to indicate that the Setting mode is active.

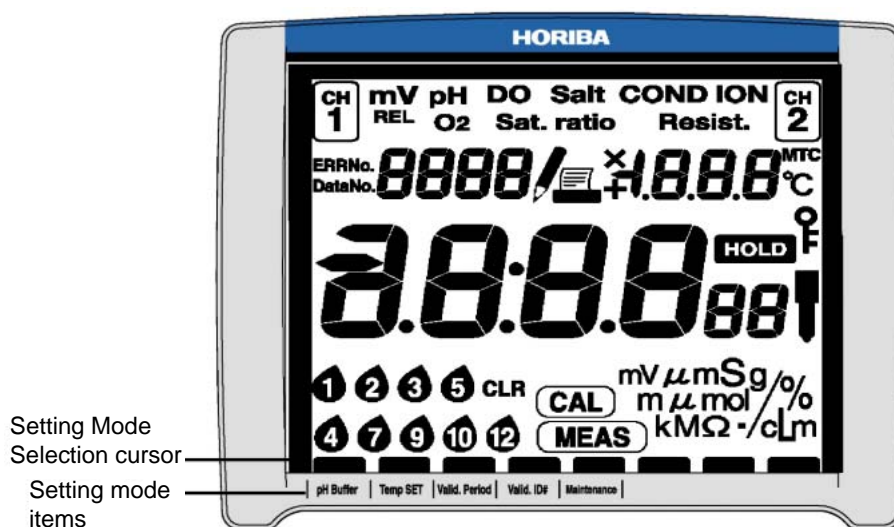

2. Pressing the SET key moves the Setting Mode Selection cursor one by one to allow you to select the Setting mode of your choice.

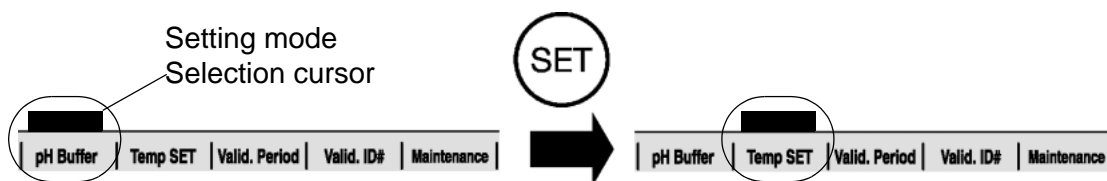













3. Press the MEAS key to return to the Measurement mode from the Setting mode.

Display	Name	Description	Page No.
	pH Buffer	Sets the standard solution for pH calibration.	page 35
	Temperature Compensation	Selects the Auto/Manual mode for temperature compensation.	page 38
	Calibration Frequency Setting	Sets the number of days between pH electrode calibrations.	page 39
	Sample ID	Stores the memory with putting ID to the measured sample.	page 39

Display	Name	Description	Page No.
	Maintenance	Sets various maintenance-related settings.	page 40

3.4.2 pH standard solution setting

The meter allows you to select the standard solution specifications used for calibration from among the NIST standard, US standard (USA), and user-defined standard (CUST).

NIST standard	When using the standard solution required by NIST standards
	Bottle mark     
US standard (USA)	When using the standard solution required by US standards
	Bottle mark     
Custom (CUST)	When using a user-defined standard solution
	Bottle mark   

Ref.

Refer to "Types of pH standard solutions" page 90 .

Note

The calibrated value for pH 7 standard solution is different between the NIST standards and US standards.

NIST standard: pH 6.86 (at 25°C)

US standard: pH 7.00 (at 25°C)

Changing the standard solution setting

1. Press the SET key in the Measurement mode and select the pH Buffer Setting mode.

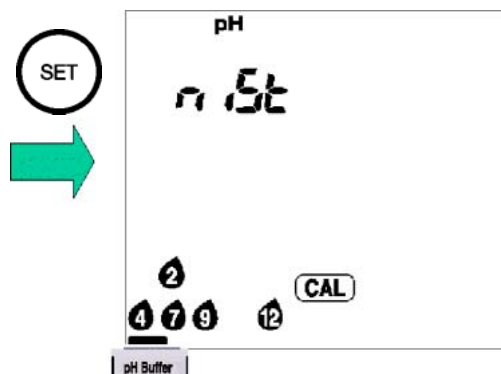

2. Press the ENTER key to toggle between Japanese standard (NIST), US standard (USA) and a user-defined standard (CUST).

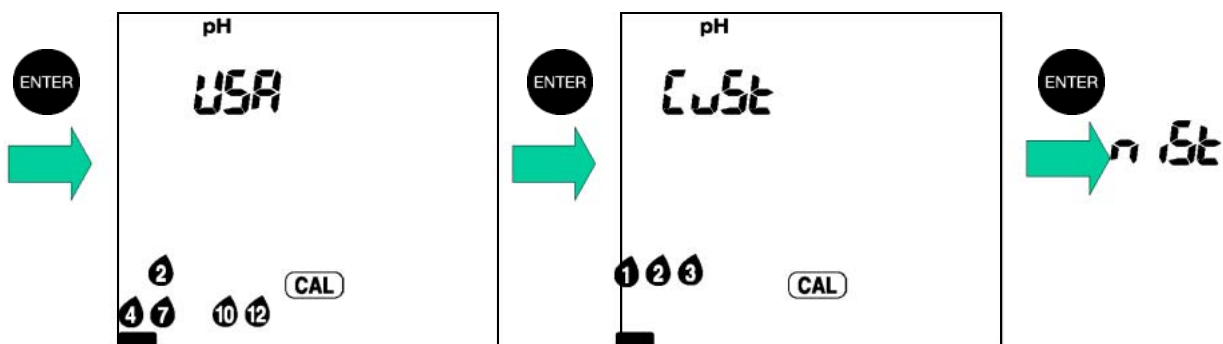

3. Press the MEAS key to return to the Measurement mode.

Calibration using a user-defined standard (CUST)

1. Press the CAL key in the pH Measurement mode to select the Calibration mode.
">CAL<" will be displayed.
2. Set the pH value of the standard solution used for calibration using the \uparrow and \downarrow keys.
While the setting is being made, the "CuSt" will blink.

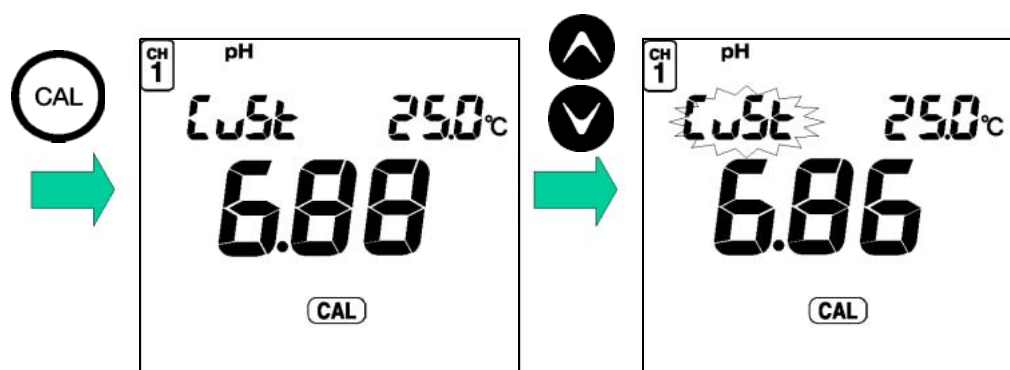

3. Press the CAL key to start the calibration.
The measured value will be displayed, and "HOLD" will blink until the reading stabilizes.
When the measured value stabilizes, "HOLD" will stop blinking and the calibrated value will be displayed.

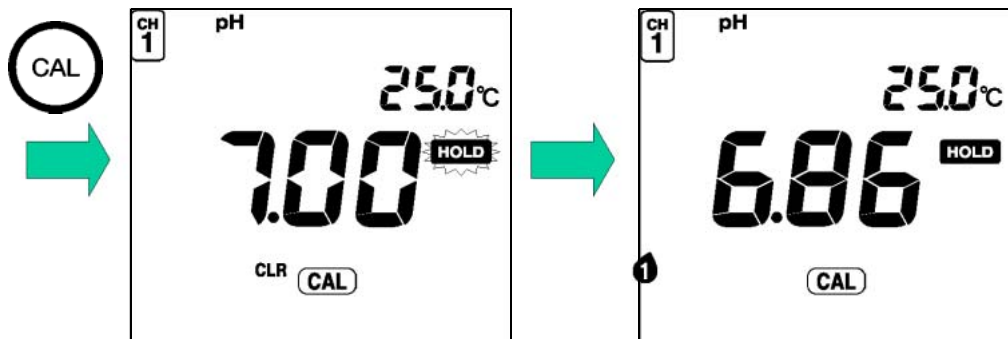

Note

Perform the calibration for the second and third point following the same procedure.

3.4.3 Temperature compensation setting

1. Press the SET key in the Measurement mode to enter the Temperature Compensation Setting mode.
2. Pressing the ENTER key toggles between MTC and ATC settings.

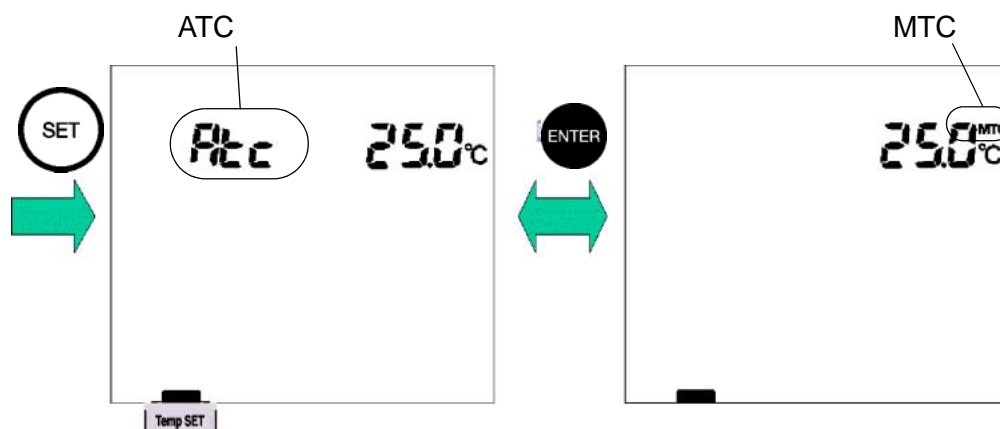

ATC

Automatic temperature compensation (when using a temperature sensor of the electrode)

ATC is displayed.

When a temperature sensor is connected, the current temperature is automatically displayed.

(When notemperature sensor is connected, the display shows 25°C)

MTC

Manual temperature compensation (when an electrode temperature sensor is not being used and the temperature of the solution is known beforehand)

MTC is displayed.

Set the temperature using the and keys.

Setting range: 0.0 to 100.0°C

3.4.4 pH calibration frequency setting

If you set a number of days in the calibration frequency setting, ERR 8 (calibration frequency error) will be displayed after the specified days have passed since the last calibration.

1. Press the SET key in the Measurement mode to select the Calibration Interval Setting mode.
2. Pressing the ENTER key toggles the calibration frequency setting between ON and OFF.

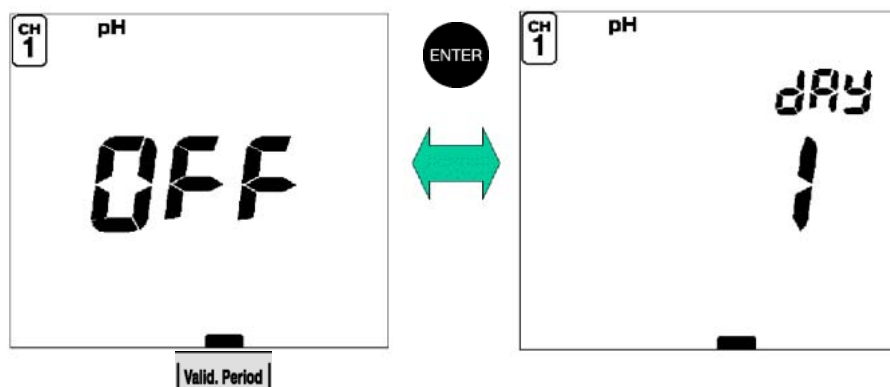

3. Specify a numerical value using the **▲** and **▼** keys.
Setting range: 1 to 400 days

3.4.5 Sample ID# setting

Setting the sample ID# records its sample ID number as well as the measured data at time the data is stored.

1. Press the SET key in the Measurement mode to enter the Valid ID# Setting mode.



2. Use the ENTER key to select the digit.
3. Specify a numerical value using the **▲** and **▼** keys.
Setting range: 00000 to 99999

3.4.6 Maintenance mode

Press the SET key in the Measurement mode and select the Maintenance mode. The LCD CHECK screen (Item No. 00) will appear.

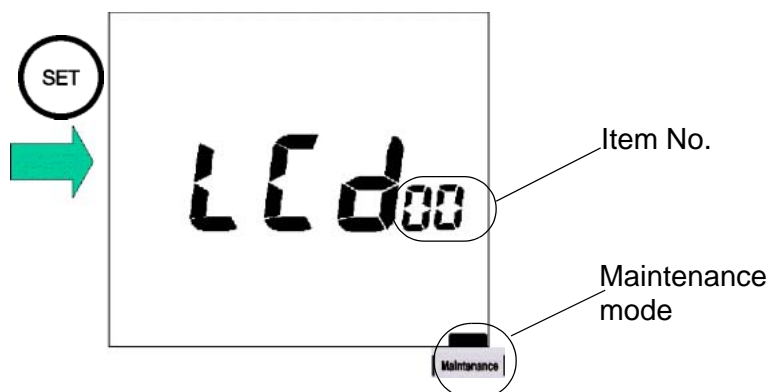

Maintenance setting items

Use the MODE key to toggle between Maintenance mode items.

Item No.	Item	Description	Page
00	LCD check	Enables check to see if all LCD segments are displayed.	page 41
01	Battery voltage check	Enables simple battery voltage check.	page 42
02	Temperature zero adjustment	Carries out temperature calibration when the temperature sensor is immersed in a liquid of known temperature.	page 43
03	Automatic power-off setting	Turns Automatic Power-off function ON/OFF and sets time period after which the power will be turned off when no keys are touched.	page 44
05	Remaining data memory	Displays number of data items that can still be stored.	page 45
06	Data memory clear	Clears all data in the data memory.	page 45
07	Initialization of setting	Initializes all settings to default values.	page 46
08	Printer connection and printing test	Carries out a printing test.	page 47

LCD check [item No. 00]

Displays all segments of the LCD.

1. Press the MODE key in the Maintenance mode to show item No. 00.
2. Press the ENTER key.

Compare the LCD screen with this diagram to confirm that all segments of the LCD are displayed.

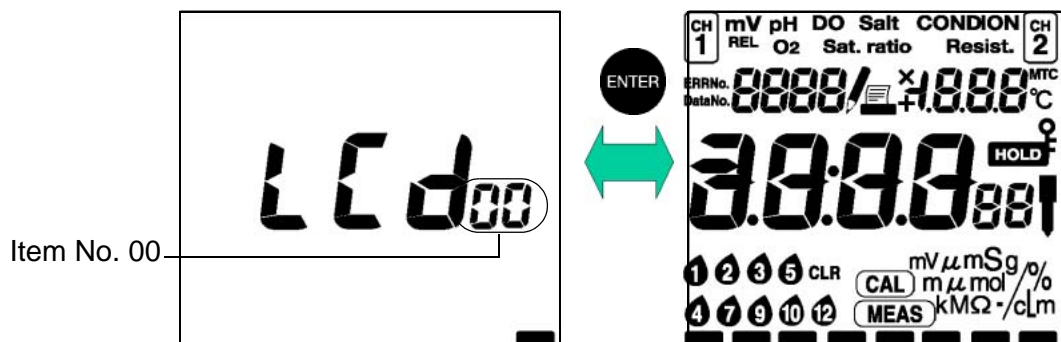

3. Use the MODE key to proceed to the Battery voltage check (item No. 01).

HINT!

Entering the Maintenance mode

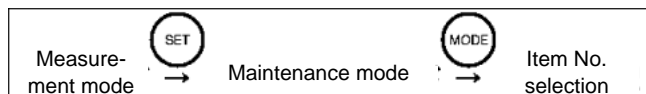

Battery voltage check [item No. 01]

The battery voltage (V) is displayed.

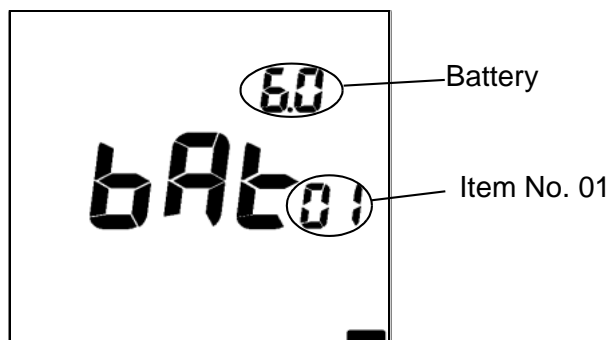

Note

The battery voltage alarm is set at approximately 4.4 V. The measured voltage for batteries depends on the current. The voltage shown in this mode will be a little lower than the actual voltage.

1. Use the MODE key to proceed to temperature zero adjustment (item No. 02).

HINT!

Entering the Maintenance mode

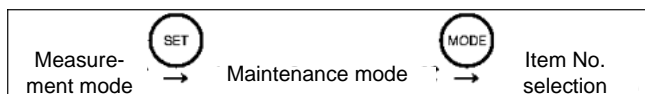

Temperature zero adjustment [item No. 02]

This mode uses a known temperature to calibrate the temperature compensation value.

1. Immerse the electrode in a liquid with a known temperature, and set the temperature using the **←** and **→** keys.

Setting range: 0.0 to 100.0 °C

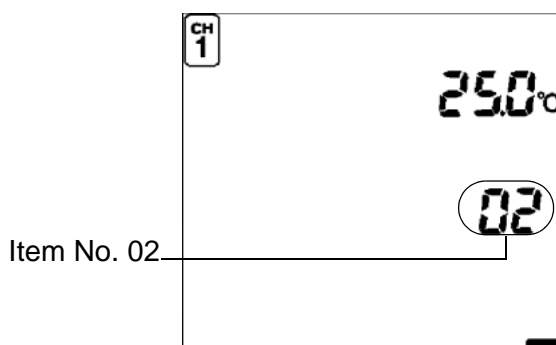

Note

The temperature sensor attached to the electrode maintains an accuracy of $\pm 1^\circ\text{C}$, even without calibration. The mode should be used when a greater precision than $\pm 1^\circ\text{C}$ is required.

2. Use the MODE key to proceed to Automatic power-off setting (item No. 03).

HINT!

Entering the Maintenance mode

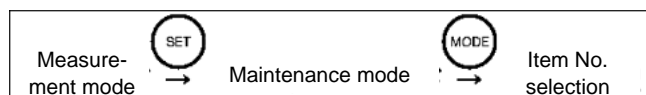

Automatic power-off setting [item No. 03]

This turns the Automatic Power-off function ON/OFF and sets the time until the power is turned off.

When the automatic power-off function is set to ON, the power to the pH meter automatically turns off if the keys are not operated for the set amount of time.

1. Press the ENTER key to toggle between ON and OFF.
When set to ON, set the time for the power to be turned OFF using the and keys.
Setting range: 1 to 30 minutes

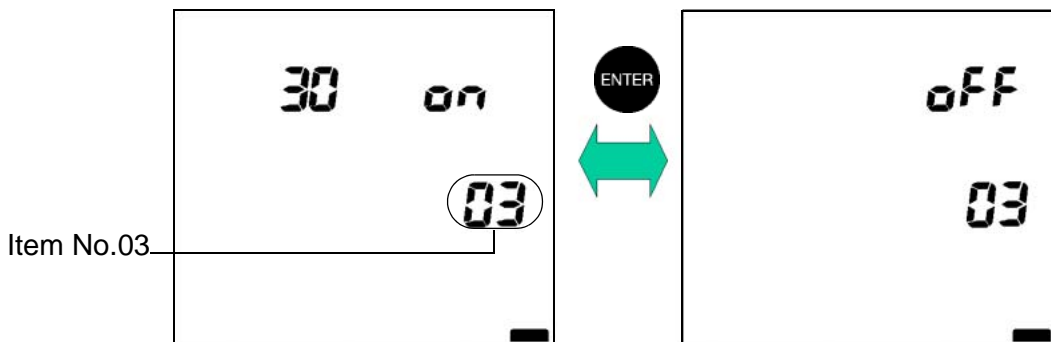

2. Press the MODE key to proceed to [Item No. 05] Remaining data memory.

— **HINT!** —
Entering the Maintenance mode

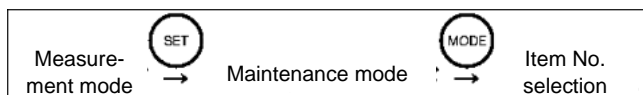

Remaining data memory [Item No. 05]

Displays the number of data items that can still be stored.

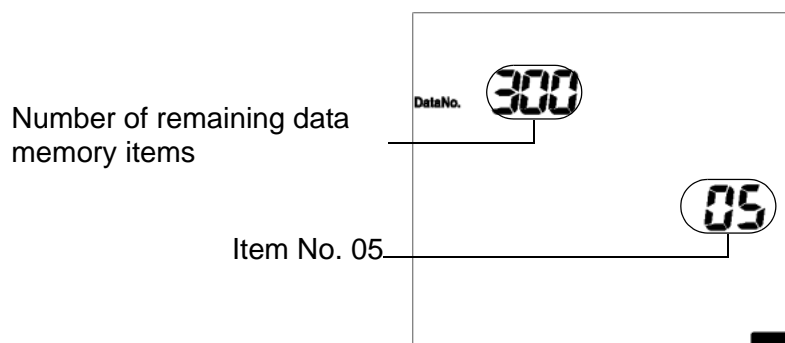

1. Press the MODE key to proceed to Data memory clear (item No. 06).

— **HINT!** —

Entering the Maintenance mode

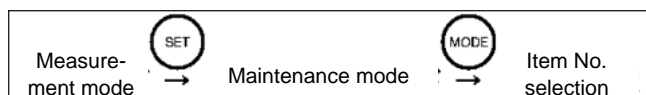

Data memory clear [Item No. 06]

1. Pressing the ENTER key clears all the data stored in the memory.

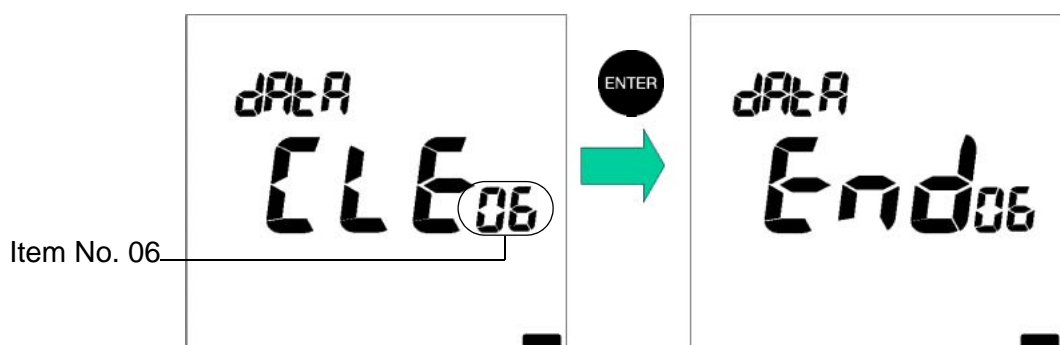

2. Press the MODE key to proceed to Initialization of setting (item No. 07).

— **HINT!** —

Entering the Maintenance mode

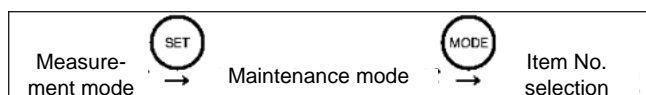

Initialization of setting [item No. 07]

This mode returns all settings to the default settings. Use this mode to return the pH meter to the original settings when the meter was purchased.

1. Press the ENTER key to initialize the settings.

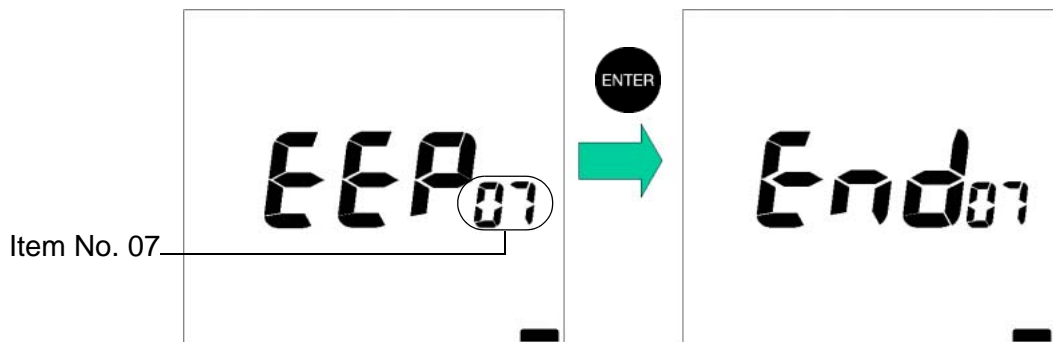

2. Use the MODE key to proceed to Printer connection and printing test (item No. 08).

— **Ref.** —

The setting values to be initialized are shown on page 100.

— **HINT!** —

Entering the Maintenance mode

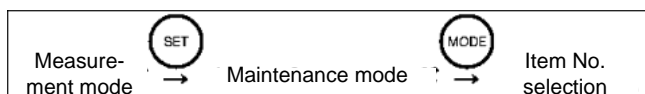

Printer connection and printing test [item No. 08]

A printing test is conducted if a printer is connected.

1. Press the ENTER key to start the printing test.

When conditions are normal, "End" is displayed. When conditions are not normal, "Err" is displayed.

When the printer is connected or power is ON.

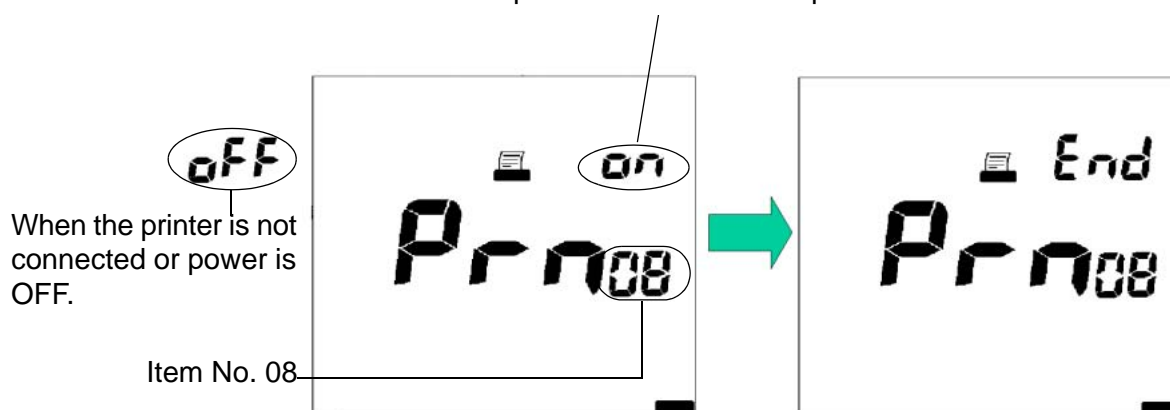

2. Press the MODE key to return to the first item in the maintenance modes, LCD check.

Test print format

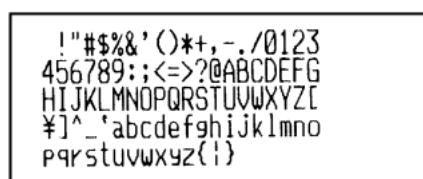

— HINT! —

Entering the Maintenance mode

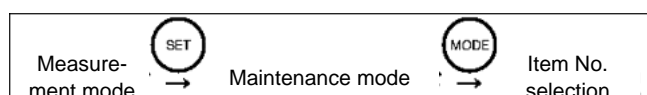

Chapter 4 RS-232C communications

This chapter describes the use of RS-232C communications and its communication commands.

4.1 Cautions before use

Use caution regarding the following points, when using RS-232C communications.

- Use the following designated cable for connecting to the computer.
Part name: PC cable for 50 Series
Part number: 9096004800
- Make sure that the data transfer formats for the meter and computer match. The following data transfer format is used by the meter.
Baud rate: 2400 bps
Character length: 8 bits
Parity: None
Stop bits: 1

Note

If the data transfer formats differ, communications errors may occur or the on-line mode may not start up, and RS-232C communications cannot proceed normally. If the transfer format is changed, turn the power to both the pH meter and the computer OFF, and then ON again.

- When creating a program for RS-232C, put the meter in the ON-LINE mode by entering an on-line command at the beginning of the program. The control switches become invalid when the meter is in the ON-LINE mode, and the RS-232C Communications mode is enabled " LOCK " is displayed. The ON-LINE mode is cleared when the power is turned OFF.
- If data is requested but not received, create the program structure to have the data request repeated after a short waiting time. This will provide more reliable communications.
- If RS-232C communications is not used, cover the RS-232C port with a rubber cap.
- This system does not carry out control using DCD, CTS or DSR. Note this point when creating a program.

4.2 Command list

Use <CR><LF> as the terminator for serial communication commands. All the commands (except the ON-LINE/OFF-LINE command) are valid only in the ON-LINE mode. (An error message is returned in the OFF-LINE mode.)

The meter returns a response to any operation made in the following format:

OK<CR><LF>

If the pH meter does not accept the operation, it returns an error message in the following format:

ER,n<CR><LF>

n= 0: Communication error

1: When a non-existent command is input.

2: When a timing command is input to which the meter cannot respond.

3: When the numerical value in the command is out of the setting range.

On-line operations commands

Command item	Command		Page No.
	Header	Command code	
On-line/off-line	C	OL	page 52
Halt potential hunting		BR	page 53
pH Measurement mode designation		PH	page 52
mV Measurement mode designation command		MV	page 52
Start measurement		MS	page 53
Start pH standard solution calibration		CP	page 53
Clear calibration		CC	page 53
Data clear		DC	page 54
Data IN designation		IN	page 54
Power Off		OF	page 54

Request data commands

Request for ...	Command		Page No.
	Header	Command code	
pH calibration history	R	PC	page 58
Clock data	R	OT	page 58
Measurement		MD	page 59
Number of stored data items		MC	page 61
Memory data		MS	page 62
Model inquiry	A	RS	page 62
Software version inquiry		AV	page 64

4.3 On-line operation commands

This section explains the commands that control the operation of the meter.

ON-LINE/OFF-LINE command format

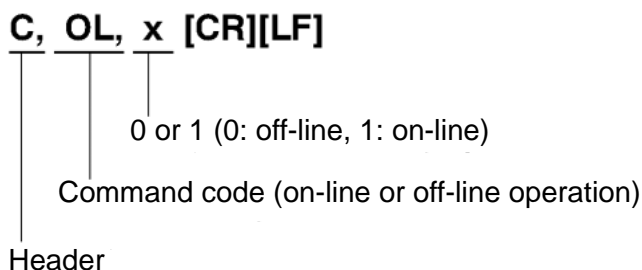

Note

Switching between on-line and off-line. When the meter is switched from off-line to on-line, the status of the pH meter is the same as when a command has been received. "LOCK" is displayed.

pH Measurement mode designation command format

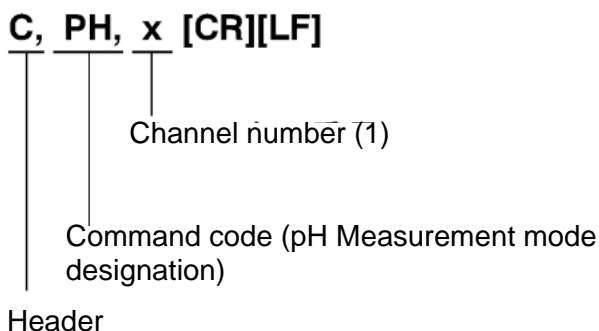

- This command is always valid when on-line.
- The meter changes the status to pH Instantaneous display for the selected channel number.

mV Measurement mode designation command format

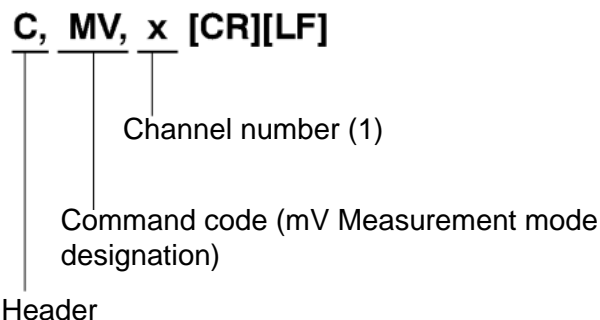

- This command is always valid when on-line.
- The meter changes the status to mV Instantaneous display for the selected channel number.

Start measurement command format

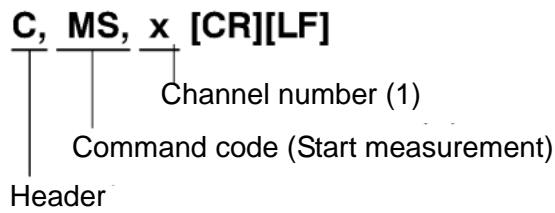

- When the meter status is Instantaneous Value Measurement, Auto Hold Measurement will start.
- If the command is issued during a measurement hold or during calibration, the meter will return to Instantaneous Value Measurement status.

Halt potential hunting command format

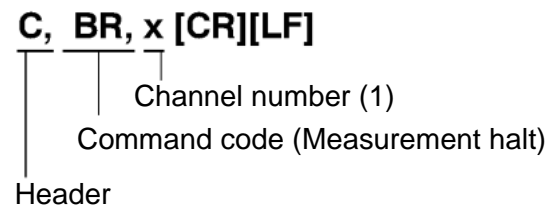

- This command is valid when on-line only during measurement on AUTO HOLD.
- Issuing this command halts measurement on AUTO HOLD.

Start pH standard solution calibration command format

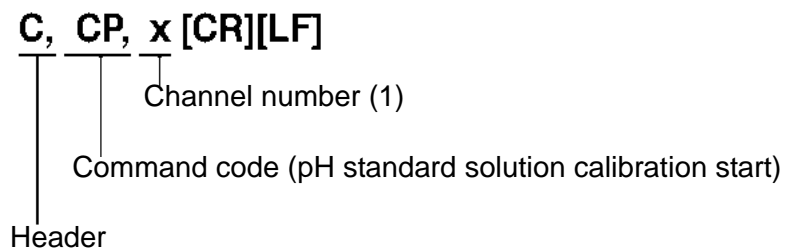

- This command is valid when on-line, during pH measurement or “HOLD” is being displayed.
- This command is valid only when the meter is set for NIST or USA calibration.
- Issuing this command starts the pH standard solution calibration.

Clear calibration command format

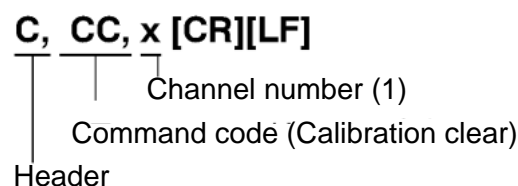

- This command is valid when on-line, when “HOLD” is being displayed for ion or pH calibration.
- When a pH electrode is being calibrated, the pH standard calibration value is cleared.

Data clear command format

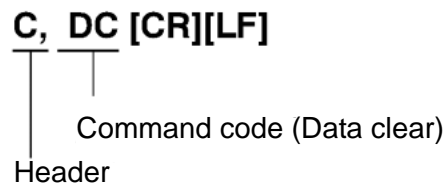

This command clears the data retained in the memory.

Data IN designation command format

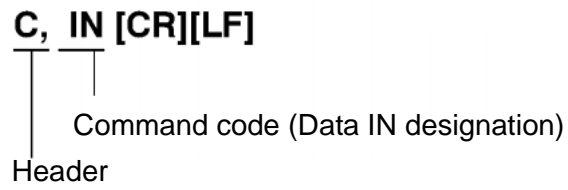

Power Off command format

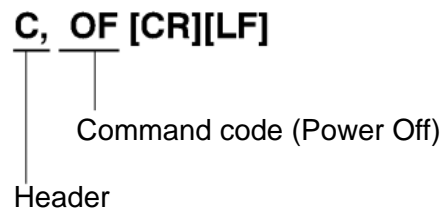

4.4 Data request commands and responses

This section explains the commands that request meter data.

Format of responses from meter

When no operation can be received

ER, n [CR][LF]

n = 0: Communications error

1: Command code does not exist

2: Unacceptable timing entered

3: Data exceeds range

When operation has been received

A. When data is requested, the result of the request is sent out according to each format.

B. When an operation command has been issued, "OK" is sent back.

Format

OK [CR][LF]

pH calibration history request command and response

Request command format

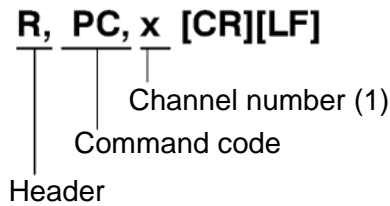

pH meter response format

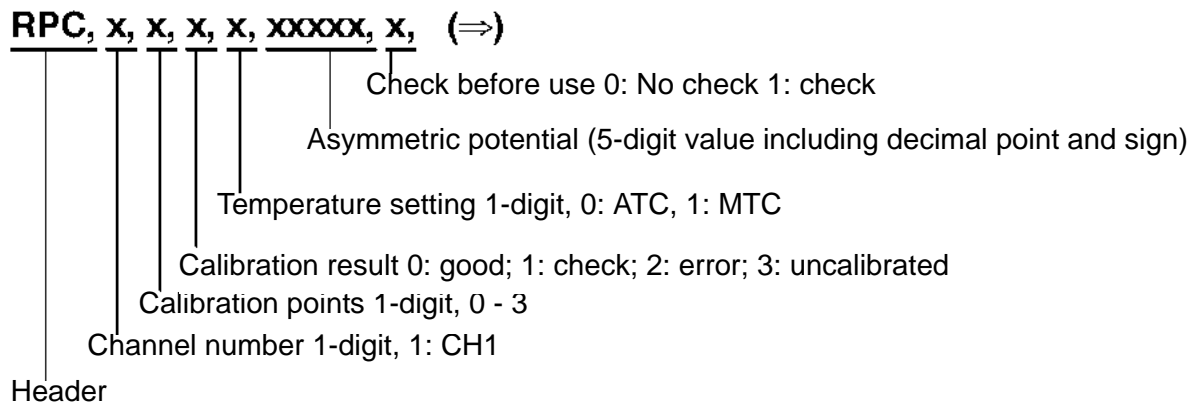

Slope (sensitivity), potential (5 digits including decimal point and sign)

*Potential is output for 1-point and 2-point calibration data.

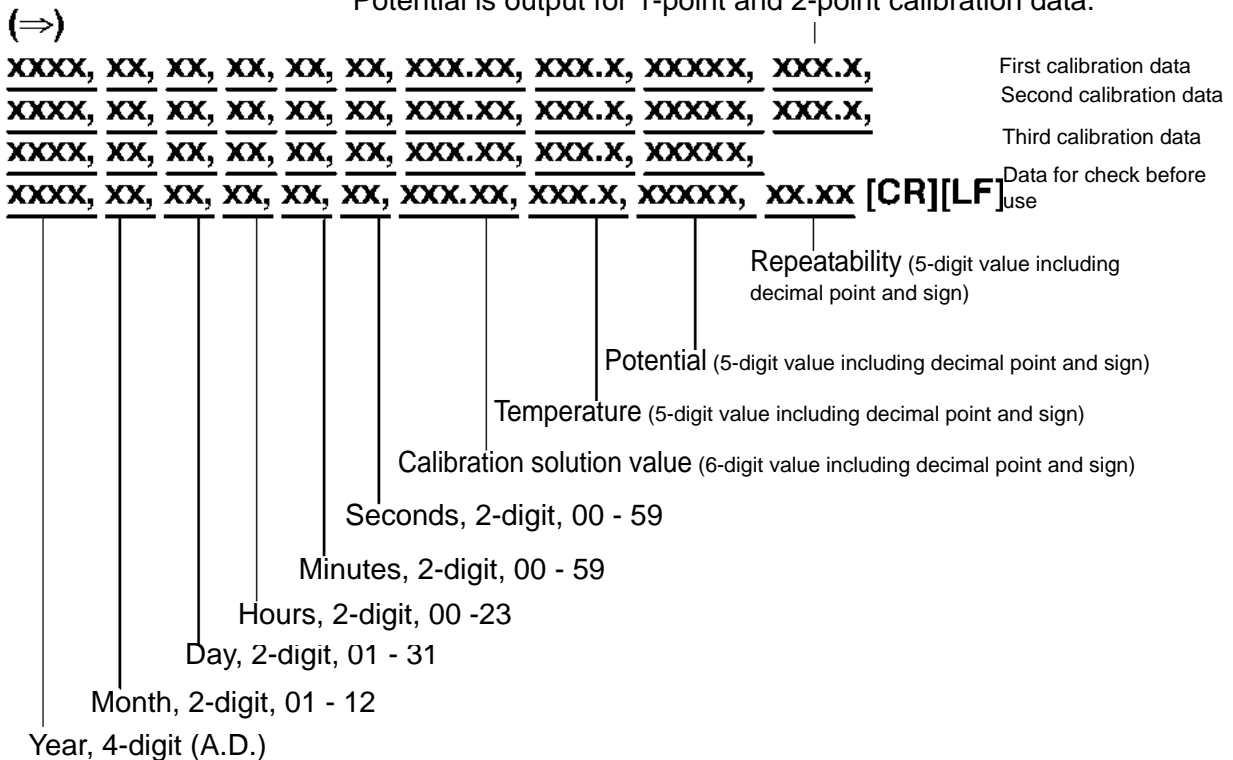

- The format is of fixed length. When there is no data, enter a [SP].
- The calibration data is transmitted only for the number of calibration points used.
- The date and time when the latest calibration was performed is output as the calibration date/time.
- The slope is valid only for calibration with 2 or more points and the slope value for the third point will be a space.
- If the check before use has been performed, this data will be sent after calibration data is transmitted.

Slope data

- Slope data is output as the calibration coefficient A between each point multiplied by 100.
- When results exceed 999.9 or are negative, the output is [SP][SP][SP][SP][SP].
- During calibration, an error response will be issued.
- The year/month/day are output for each calibration point.

Clock data request command and response

Request command format

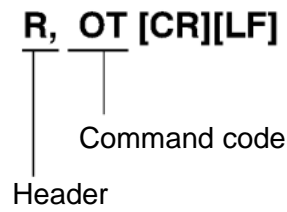

Meter response format

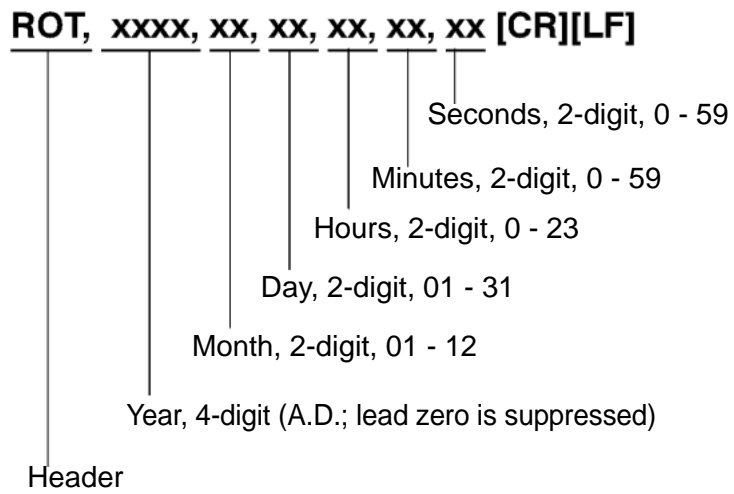

Measurement request command and response

Request command format

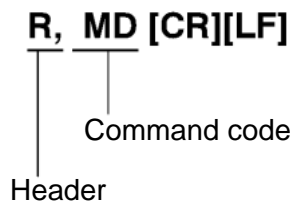

Meter response format

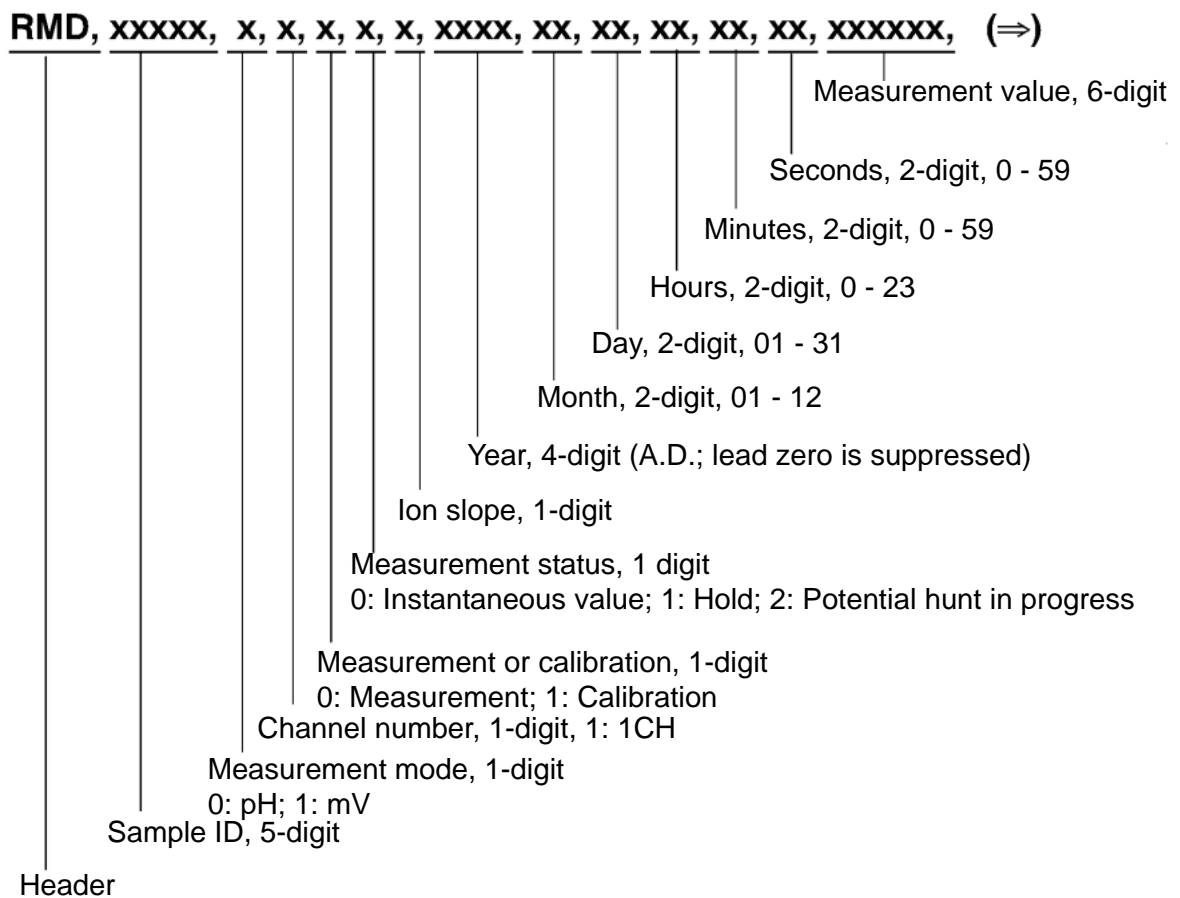

(⇒) x, x, x, xxxxx, xxxxx, xx [CR][LF]

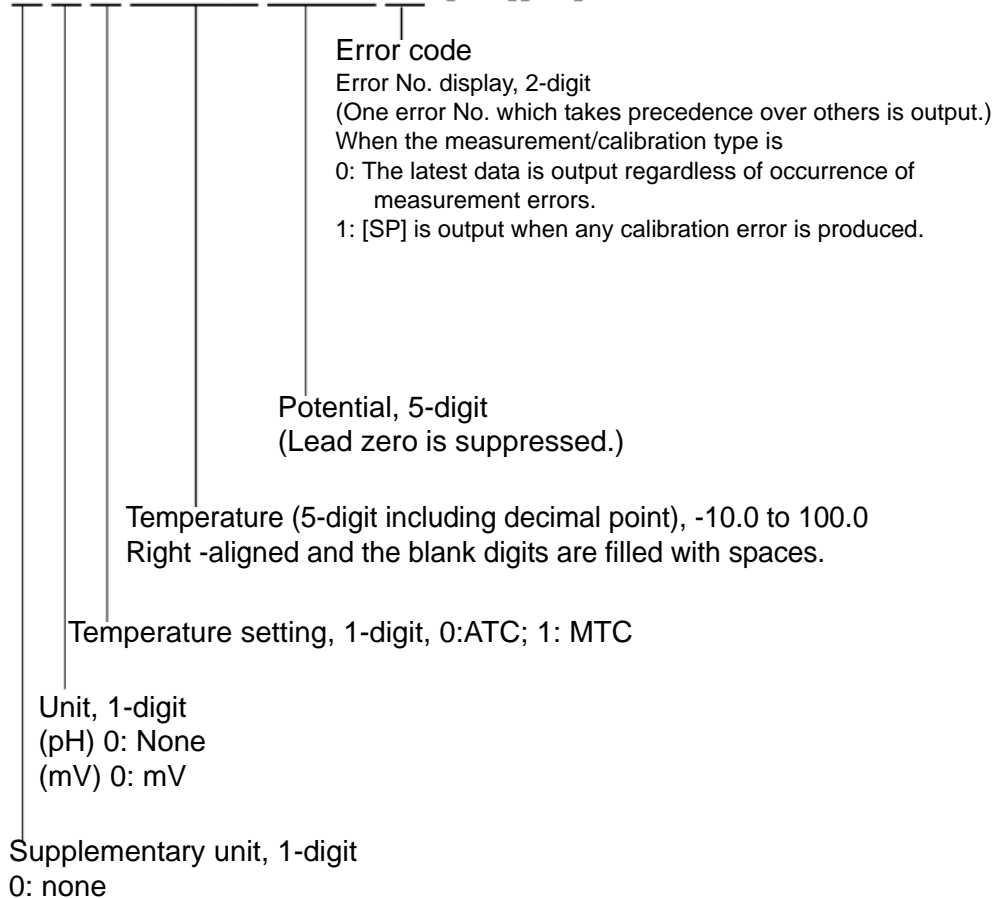

Request command for number of stored data items and its response

Request command format

R, MC [CR][LF]
| |
Header Command data

Meter response format

RMC, xxx [CR][LF]
| |
Header Number of data items

Request command for memory data and its response

Request command format

R, MS, yyy [CR][LF]

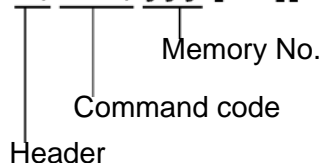

Meter response format

RMS, xxx, y, zzzzz, ... (⇒)

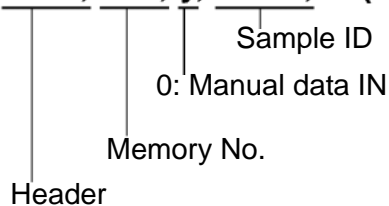

(⇒) x, x, x, x, x, xxx, xx, xx, xx, xx, xx, xxxxxx, (⇒)

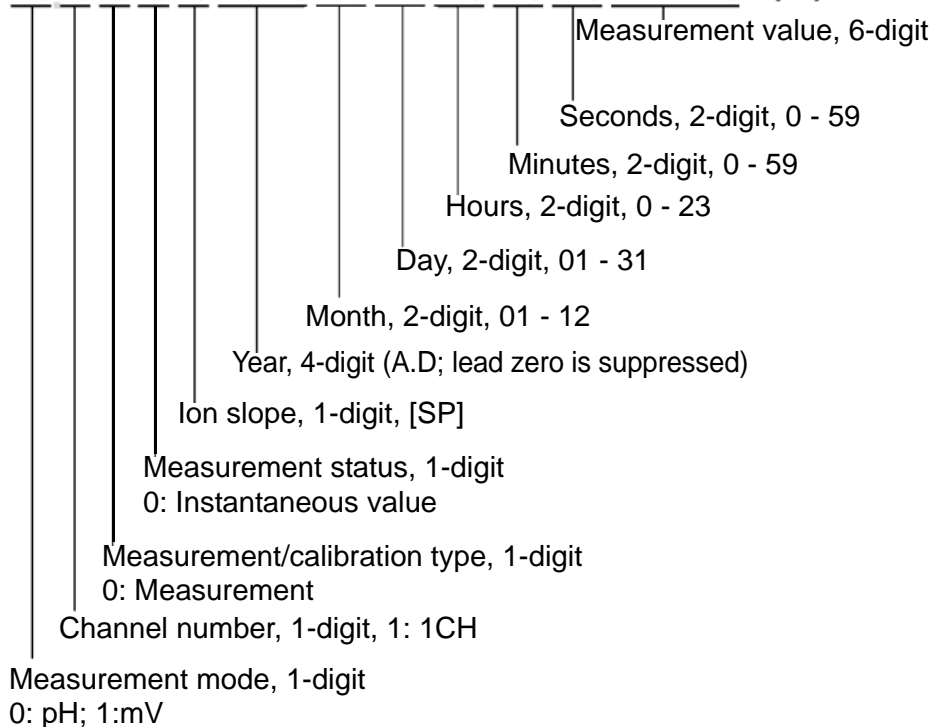

(⇒) x, x, x, xxxxx, xxxxx, xx [CR][LF]

Error code

Error No. display, 2-digit

(One error No. which takes precedence over others is output.)

When the measurement/calibration type is

0: The latest data is output regardless of occurrence of measurement errors.

1: [SP] is output when any calibration error is produced.

Potential, 5-digit

(Lead zero is suppressed.)

Temperature (5-digit including decimal point), -10.0 to 100.0

Right-aligned with blank digits filled with spaces.

Temperature setting, 1-digit, 0:ATC; 1: MTC

Unit, 1-digit

(pH) 0: none

(mV) 0: mV

Supplementary unit, 1-digit

0: none

Request command for model and its response

Request command format

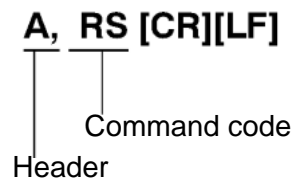

Meter response format

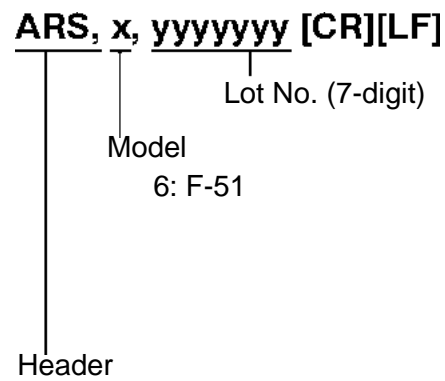

Request command for software version and its response

Request command format

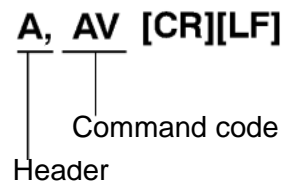

Meter response format

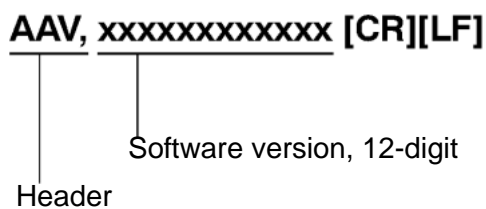

4.5 Communication example using the HyperTerminal

For reference, communication using the HyperTerminal that comes with Windows is described here.

1. Open the HyperTerminal.
[Start] > [Programs] > [Accessories] > [Communications] > [HyperTerminal]
The HyperTerminal program (Hypertm.exe) is activated.
2. Make the setting for name, connection, and port.
Select the COM port of your PC currently being used for the port setting.
3. Set the COM port of the PC and set the transmission parameters as follows:
Baud rate: 2400 bps
Character length: 8 bits
Parity: none
Stop bit: 1 bit
4. Make the settings in the properties dialog box.

[File] > [Properties] > [Settings]

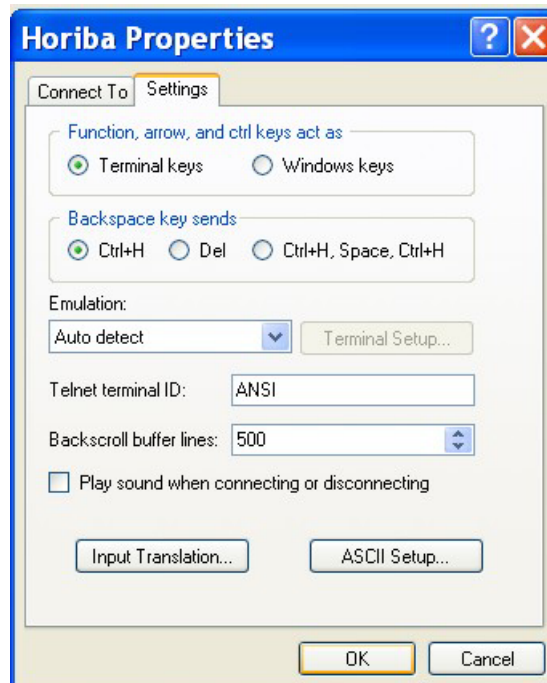

[File] > [Properties] > [Settings] > [ASCII Setup]

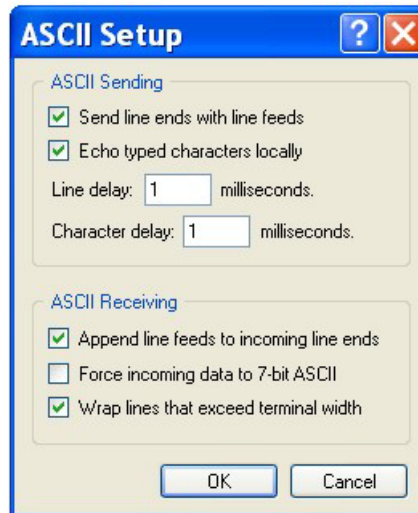

Note

You can check the contents transmitted via HyperTerminal by enabling the “Echo typed characters locally (E)” option.

5. Command input

If a command is input, the corresponding response data is sent back.

Command input should be completed within 10 seconds.

Be sure to first set the meter to the On-line mode using the On-line/Off-line command.

Note

Windows® is a registered trademark of Microsoft Corporation.

Chapter 5 Printer

This chapter explains the printer connection, the times printing takes place, and printing formats.

5.1 Connecting the printer

The following printers are compatible with the pH meter.

Printers

- Citizen CBM-910-24RJ100-A (Normal paper)
- Seiko DPU-H245AS-A03A (Heat-sensitive paper)

Attach the printer cable to the printer output connector.

Note

Connect your printer only after turning OFF the power to the main unit of the pH meter.

Ref.

For the layout of the connector terminals for the printer output cable, refer to "7.6 Pin layout of special cables" page 102.

Note

When a printer is not connected, remove the printer cable from the meter and put the rubber cap securely over serial communication connector. Be sure to use a cable that matches the printer.

5.2 Printer setting

Set up the printer using these settings:

- Printer output baud rate: 2400 bps
- Bit length: 8 bits
- Parity: none

Setting for a plain paper printer (CBM-910)

Set DIP switch No. 6 to ON and No. 7 to OFF, and prepare the printer paper and ink ribbon. Keep the LF key held down. The printer prints only when the LF key is being pressed.

Setting for a thermal paper printer (DPU-H245AS)

Prepare printer paper and turn ON the power switch with the FEED and CHARGE switches held down. Set the baud rate of the printer to the above value, referring to the instruction manual for the printer.

Start the function setting mode of the printer and change it to the above settings.

5.3 Printer output timing

The printer prints at the following times:

- When pressing the ENTER key after HOLD or while the instantaneous value is being displayed in the Measurement mode.
- When the manual data memory storage is performed in the Measurement mode.
- When pressing the ENTER key while in the Data Memory Call mode.
- When calibration or check is performed in the Calibration mode.
- When the ENTER key is pressed in the calibration history display.
- When test printing is selected while in the Maintenance mode.

5.4 Printing format

The following are sample printouts.

5.4.1 When the ENTER key is pressed in the Measurement mode

pH Measurement mode

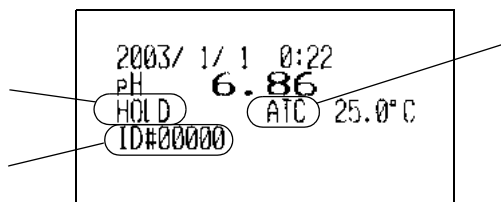

When the data is the data confirmed with Auto Hold, "HOLD" is shown. Nothing is displayed for the instantaneous value measurement.

ID#: 5 digits

Temperature compensation setting

Manual mode: MTC

Auto mode: ATC

mV Measurement mode

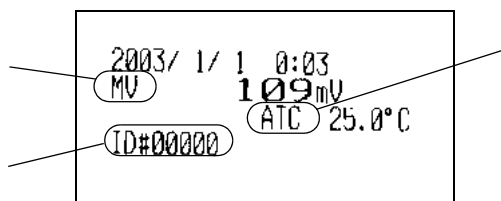

REL is displayed during relative mV measurement.

ID#: 5 digits

Temperature compensation setting

Manual mode: MTC

Auto mode: ATC

5.4.2 When the manual data memory is performed in the Measurement mode

The printer prints the data memory No. in the first line and the data in accordance with the format same with the one in "5.4.1 When the ENTER key is pressed in the Measurement mode" page 70.

Example in the pH Measurement mode

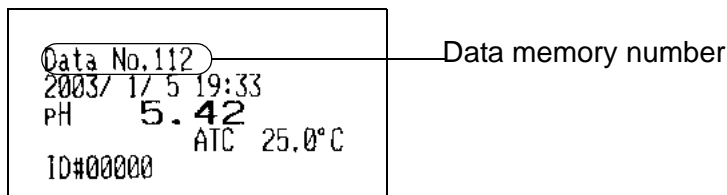

5.4.3 When the ENTER key is pressed in the Data Memory Call screen

The format is the same at that described in "5.4.2 When the manual data memory is performed in the Measurement mode" page 71.

5.4.4 When calibration or check is performed in the Calibration mode

pH calibration

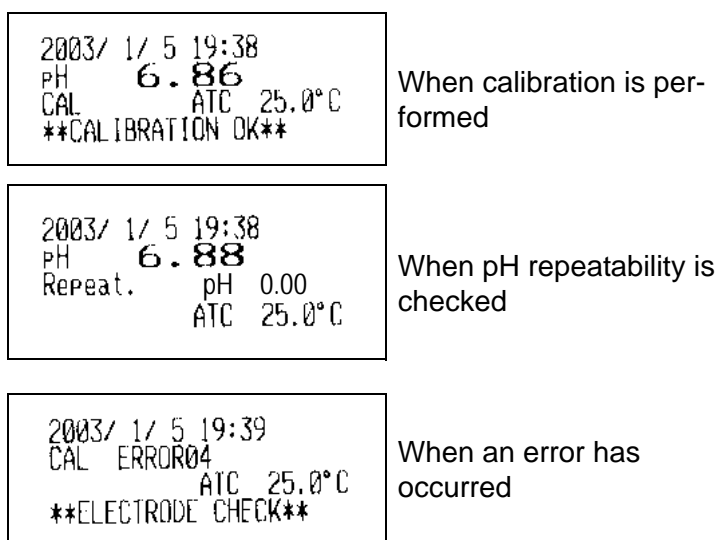

5.4.5 When the ENTER key is pressed in the calibration history display

pH calibration history (without check data)

Asymmetrical potential at calibration

Calibration data

```

CALIBRATION: BAD
Date      ; 2003/ 1/ 1
mV Value  ; -7mV
Slope
pH 6.86- 4.01  86.4%

CAL DATA
2003/ 1/ 1  0:19
pH 6.86      0mV
              ATC 25.0°C
2003/ 1/ 1  0:19
pH 4.01      146mV
              ATC 25.0°C
          
```

Electrode status:
GOOD: good condition
CHECK: Washing is needed.
BAD: Replace

Sensitivity display
Standard solution value is displayed.
No calibration/1-point calibration: None
2-point calibration: 1st item
3-point calibration: 2nd item

pH calibration history (with check data)

Calibration data

```

CALIBRATION: GOOD
Date      ; 2003/ 1/ 5
mV Value  ; -7mV
Slope
PH 4.01- 6.86  98.4%
PH 6.86- 9.18  97.6%
Repeat.   ; 0.00PH

CAL DATA
2003/ 1/ 5 19:51
PH 4.01      167mV
              ATC 25.0°C
2003/ 1/ 5 19:51
PH 6.86      1mV
              ATC 25.0°C
2003/ 1/ 5 19:52
PH 9.18     -133mV
              ATC 25.0°C
2003/ 1/ 5 19:52
PH 6.86      1mV
              ATC 25.0°C
          
```

Value of repeatability check

5.4.6 Test printing format in the Maintenance mode

```

!"#$%&'()*+,-./0123
456789:;<=>?@ABCDEFGH
IJKLMNOPQRSTUVWXYZ[
¥]^_`abcdefghijklmnop
qrstuvwxyz{|}
          
```

Chapter 6 Maintenance and Troubleshooting

This chapter explains how to perform daily meter maintenance and how to deal with error messages.

Daily maintenance is vital in assuring accurate measurement and preventing breakdowns before they occur. Maintenance of the electrodes is especially important; if ignored, various problems and erroneous measurements may result. This pH meter is equipped with a convenient error message function. If an error message is displayed, be sure to take appropriate action.

6.1 pH (ORP) electrode maintenance

Maintain your electrodes by referring to the following information or to the operation manuals for the electrodes.



Caution

Injury warning

Glass fragments can cause injury. The outer tube of the electrode and the tip of the electrode are made of glass. Use care not to break them.

The following explanation is for pH electrodes (9621-10D) ORP electrodes should be cared for in the same manner.

Maintenance after daily use

After taking measurements, wash the electrode using pure water (de-ionized water), wipe off the water from the electrode with filter paper or tissue paper, and store it with its cap on.

Note

The liquid junction may become clogged if the electrode is left in distilled water.

Extended storage

When an electrode is not to be used for a long period of time, store the electrode after performing the following steps. Also, replace the reference solution every three to six months, using the method explained below.

1. Remove the electrode from the pH meter.
2. Remove the protective cap from the electrode.

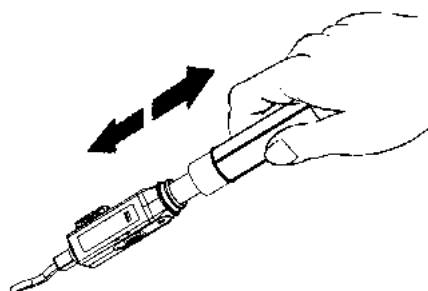

Chemical warning



Caution

The liquid inside the electrode is highly concentrated potassium chloride (3.33 mol/L KCl). If the internal solution in the electrode comes in contact with your hands or skin, wash immediately with water. If the internal solution comes in contact with your eyes, flush immediately with large amounts of water and seek treatment by a physician.

-
3. Open the internal solution filler port and use a syringe to remove the internal solution.

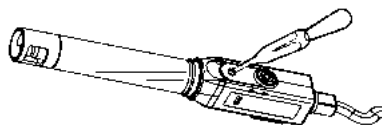

4. Fill the electrode with new reference solution (#300), until it nears the opening.

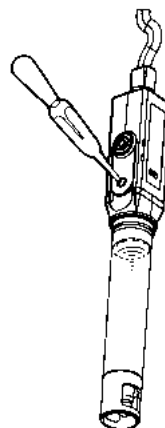

5. Wash the tip of the electrode well with pure (de-ionized) water and wipe it with filter paper or tissue paper.

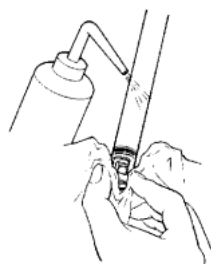

6. If the liquid on the inside of the electrode cap has dried, wash the inside of the electrode cap with pure (de-ionized) water, and then, after shaking out the water, fill the cap with enough pure water to soak the sponge.

Note

If the solution inside the protective cap for the electrode has dried up and the electrode has not been used for an extended period of time, the response speed of the electrode may be slower (and its sensitivity lower) than before.

Washing the electrodes

If the tip of the pH electrode is extremely dirty, the speed of its response may slow and it may cause errors in measurement. If the electrode is so dirty that it cannot be cleaned by rinsing with pure (de-ionized) water, wash the electrode using the most appropriate method below.

General dirt & oily grime

Wipe the dirt/grime off using cotton gauze that contains a neutral detergent.



Inorganic grime

Rinse using a hydrochloric acid solution or cleaning liquid #220 of approximately 1 mol/L. Be sure not to soak the electrode in strong acid for a long period of time.



Note

1 mol/L hydrochloric acid solution is made by diluting commercially available concentrated hydrochloric acid by a factor of ten.

6.2 Troubleshooting

The meter is equipped with a simply error-message function to notify the operator that an operation error or problem with the equipment has occurred. Errors or other problems that occur while in the Measurement mode are announced by an error No. appearing in the lower left-hand corner of the display.

6.2.1 Error message chart

Error no.	Message	Explanation
01	Memory error	Data cannot be read from or written to the internal memory.
02	Battery voltage low	The battery voltage is low.
03	Electrode stability error	The electric potential did not stabilize within three minutes.
04	Asymmetry potential error	The asymmetric potential of the electrode is 45 mV or more.
05	Sensitivity error	The electrode sensitivity is either 105% or more or 85% or less than the theoretical sensitivity.
06	Max. calibration points exceeded	No more than three points can be calibrated.
07	Cannot identify standard solution	The meter cannot identify the standard solution.
08	Calibration cycle error	Exceeds the calibration cycle setting.
09	Printer error	There is a problem with the printer.
10	Data memory over	The number of data items has exceeded the limit of the memory.

ERR No. 01 Memory error

Explanation

Data cannot be read from or written to the internal memory.

Cause	How to solve problem
The pH meter does not start operating correctly even after the power is turned ON.	Take the battery from the pH meter, and disconnect the AC adapter. Then press the ON/OFF key for about 10 seconds.
The internal IC is defective.	Seek repairs at your nearest retail outlet or HORIBA service station.

ERR No. 02 Battery voltage low

Explanation

The battery has insufficient voltage.

Cause	How to solve problem
The battery voltage is low. (Battery voltage: 4.4 V or less)	Replace the dry-cell battery.

Note

The measured value cannot be guaranteed when ERR No. 02 is displayed.

ERR 03 Electrode stability error

Explanation

The electric potential did not stabilize within three minutes.

Cause	How to solve problem
This is caused by the sample solution (when the sample solution is pure water or another solution with low conductivity or the concentration or temperature change).	Press the MEAS key again while "HOLD" is either blinking or steadily lit in the display, to measure the sample using instantaneous value measurement.
The electrode is dirty.	Wash the electrode.
The electrode is cracked.	Replace the electrode.
The responsive glass membrane of the electrode has been dry for a long time.	Soak the membrane (on the electrode) in pure (de-ionized) water for 24 hours.
The temperature of the sample solution is fluctuating.	Measure after the sample solution temperature stabilizes.

ERR 04 Asymmetric potential error

Explanation

The asymmetric potential of the electrode is 45 mV or more.

Cause	How to solve problem
The electrode is dirty.	Wash the electrode.
The electrode is cracked.	Replace the electrode.
The reference solution concentration is fluctuating.	Replace the internal solution in the reference electrode.
The electrode is not connected correctly.	Connect the electrode correctly.
The electrode is not submerged deeply enough to cover the liquid junction (tip).	Immerse the electrode in the sample at least three centimeters deep.
There is problem with the standard solution.	Prepare new standard solution.

ERR 05 Electrode sensitivity error (pH)

Explanation

The electrode sensitivity is either 105% or more or 85% or less than the theoretical sensitivity.

Cause	How to solve problem
The electrode is dirty.	Wash the electrode.
The electrode is cracked.	Replace the electrode.
Calibration was not performed correctly.	Redo the calibration correctly.
There is a problem with the standard solution.	Use fresh standard solution.
The electrode is not connected correctly.	Connect the electrode correctly.
Electrode is not submerged deeply enough to cover reference junction.	Immerse the electrode in the sample at least three centimeters deep.

ERR 06 Max. calibration points exceeded

Explanation

Calibration was performed on a fourth calibration point.

Cause	How to solve problem
Calibration was performed on a fourth calibration point.	Limit the number of calibration points to three. This error message is cleaned by setting the meter to Measurement mode.

Note

This error does not affect calibration data obtained from previous three calibration points.

Ref.

Refer to " Standard solution calibration" page 18.

ERR 07 Cannot identify standard solution

Explanation

If the automatic standard solution identification function of the meter does not work, recalibrate the meter after performing the appropriate measures below.

Cause	How to solve problem
There is a problem with the standard solution.	Prepare new standard solution.
There is a problem with the standard solution setting.	Check the NIST or US standards settings and the kind of standard solution used for calibration, and make sure they match.
The responsive membrane is dry or dirty.	Measure after washing the responsive membrane and soaking it in pure (de-ionized) water for 24 hours.
The reference solution is contaminated.	Replace the reference solution with new solution.
The responsive membrane is damaged or worn out.	Replace the electrode.

ERR 08 Calibration cycle error

Explanation

This error appears when the number of measurements set for the calibration cycle has been exceeded since the last calibration was conducted.

Calibrate again.

ERR 09 Printer error

Explanation

If a problem occurs with the printer, turn OFF the power to the meter, perform the appropriate measure below, and turn the power to the meter back ON.

Cause	How to solve problem
The printer paper is jammed.	Remove the jammed paper.
There is no printer paper.	Load the printer with paper.
There is a problem with the printer connection.	Reconnect the printer after making sure there is nothing wrong with the connector parts.
The printer is defective.	Replace the printer.

ERR 10 Data memory over

Explanation

The number of data items has exceeded the limit of the memory.

Cause	How to solve problem
Memory ove	Delete data stored in the memory after confirming their contents.

6.2.2 More troubleshooting

This section explains how to respond to various symptoms of trouble that are not indicated by an error number.

Nothing shows up on the display when the power is turned ON

Cause	How to solve problem
No batteries	Place batteries in the meter.
The batteries are loaded with the poles reversed.	Re-insert the batteries with the poles correctly oriented.
The battery voltage is low.	Remove the old batteries and correctly insert new dry-cell batteries. Or, connect the unit to the optional AC adapter.

The indicated value fluctuates

When there is a problem with the electrode...

Cause	How to solve problem
The responsive membrane is dry or dirty.	Wash the responsive membrane.
The responsive membrane is damaged or worn out.	Replace the electrode.
There are air bubbles on the electrode.	Shake the electrode to remove the air bubbles.
There is no reference solution remaining.	Fill the electrode with new reference solution, as noted in the electrode operation manual.
The wrong reference solution is being used.	Use the correct reference solution.

When there is a problem with the main unit of the meter...

Cause	How to solve problem
There is a motor or other device causing electrical interference.	Move the meter to a place where it is not subject to dielectric effects. Be sure to ground devices that are using commercial electricity.
The electrode is not connected correctly.	Connect the electrode correctly.

When there is a problem with the standard solution...

Cause	How to solve problem
The liquid junction is not immersed in the sample solution.	Immerse the electrode in the sample solution up until the liquid junction or deeper.
Some effects of the sample.	Determine if this is the cause by measuring with a stable standard solution.

The response is slow

Cause	How to solve problem
Some effects of the sample.	Response time may slow down, depending on the properties of the sample solution.
The electrode is dry or dirty.	Wash the responsive membrane.
The electrode is cracked or worn out.	Replace the electrode.
There is a problem with the reference solution.	Fill the electrode with new reference solution, as noted in the electrode instruction manual.

The indicated value does not change, or there is absolutely no response

Cause	How to solve problem
The key-lock function is ON.	Turn the power OFF, and then turn it back ON again.
The system is locked.	Turn the power OFF, and then turn it back ON again.
The electrode connector is not attached correctly.	Attach the electrode connector correctly.
The electrode is defective. (the responsive membrane is cracked.)	Replace the electrode.
The meter is defective.	Contact your local HORIBA distributor.

The measured value is blinking

The pH value exceeds the measurement range (when pH value is displayed).

Measurement range: pH 0.00 – pH 14.00

The mV value exceeds the measurement parameters (when mV value is displayed).

Display range: ± 1999 mV

Cause	How to solve problem
The sample solution is inappropriate.	Change to a sample solution with properties within the measurement range.
The liquid junction is not immersed in the sample solution.	Immerse the electrode in the sample solution all the way until the liquid junction or deeper.
The electrode cable has been severed.	Replace the electrode.
The main body of the meter is defective.	Check the point described below.
The meter has not been calibrated or it has been calibrated incorrectly.	Calibrate the meter correctly.

Check this point

As shown in the diagram, use a jumper wire or bent paper clip to short the meter by touching both the center pin in the electrode connector and some metal part.

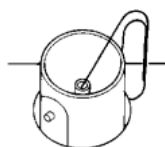

The temperature display is blinking.

The temperature display does not change from 25°C.

The temperature measurement exceeds the measurement range.

Measurement range: -10 – 100.0°C

Cause	How to solve problem
The temperature of the sample solution exceeds the measurement range.	Check the temperature of the sample solution and change to a sample solution that has a temperature within the measurement range.
The thermistor connection within the electrode is severed or shorted.	Measure the resistance of the temperature sensor connector. If it is 50 kΩ or more at room temperature, replace the electrode.
The electrode connector is not attached properly.	Attach the electrode connector properly, so that the O-ring on the temperature connector disappears from sight.
The main unit of the meter may be defective.	In Temperature Display Calibration mode (" Temperature zero adjustment [item No. 02]" page 43), check whether or not the "Minus" display appears, regardless of whether or not there is a temperature connector.
There is a problem with the setting for the temperature display calibration mode (see page 43).	" Initialization of setting [item No. 07]" page 46.

Measurements are not repeatable

Cause	How to solve problem
Some effects of the sample solution	The pH or other properties of the sample solution may have changed over time, making repeatability poor.
The responsive membrane is dry or dirty.	Wash the responsive membrane.
There is not enough reference solution or it is dirty.	Replace the reference solution with new solution.
The responsive membrane is cracked or worn out.	Replace the electrode.

When the printer will not print even though it is connected.

Check the following points:

- Is the printer turned ON?
- Has a printer error occurred?
- Is there printing paper? Has the paper jammed?
- When running a test print according to the manual, does it print out correctly?

Chapter 7 Reference

This chapter provides a simple compilation of information for those who would like to know about the functions of the main unit of the pH meter and other measurement principles in greater detail.

It also serves as a reference for spare and optional parts.

7.1 pH measurement

pH measurement and temperature

The temperature of the solution being inspected is an important parameter in the accurate measurement of pH. There are many possible sources of errors during measurement, such as the state of the solution junction potential, asymmetric potential, and reference solution pH concentration, but all of these items contain factors that change with temperature. The best way to minimize these potential causes of errors is to keep the temperature of the pH standard solution uniform at the time of calibration.

Liquid junction potential

“Liquid junction potential” is the electric potential that occurs to a greater or lesser degree at the liquid junction. The size of the electric potential differs depending on the type of solution, the temperature of the solution, and the structure of the liquid junction.

When solutions of different compositions come in contact, ion diffusion occurs on the contact surface between the two solutions. The ions are of various sizes, so a difference occurs in the diffusion transfer speed.

As diffusion proceeds, a difference in charges occurs on the contact surface of the two solutions, giving rise to a difference in potential. This potential works to reduce the transfer speed of fast ions and increase the speed of slow ions, ultimately achieving a state of equilibrium when the transfer speed of the positive and negative ions on the contact surface of the two solutions is equal. In this state of equilibrium, the potential at the contact surface between the two solutions is called the “liquid junction potential.” A large liquid junction potential means measurements will be very inaccurate.

Asymmetric potential

The glass electrode is immersed in a pH 7 reference solution. When the electrode is immersed in the pH 7 solution, both the internal and external sides of the electrode membrane are supposed to take on a pH of 7, making the potential 0. In actuality, however, a potential does occur. This potential is called “asymmetric potential.” The size of the asymmetric potential differs depending on any stress that may have occurred during the processing of the glass and the shape and compositions of the glass. Asymmetric potential also changes

depending on the degree of contamination of the reference solution and the state of the glass membrane. Also, if the electrode membrane dries out, a large asymmetric potential will occur, giving rise to measurement errors.

Temperature compensation

The electromotive force generated by the glass electrode changes depending on the temperature of the solution. “Temperature compensation” is used to compensate for the change in electromotive forces caused by temperature. There is absolutely no relation between the change in pH caused by the temperature of the solution and temperature compensation. This is often misunderstood. When pH is to be measured, the temperature of the solution when the pH is measured must be recorded along with that pH value, even if a meter that has automatic temperature compensation is used. If the solution temperature is not recorded, the results of the pH measurement are relatively meaningless.

Types of pH standard solutions

When measuring pH, the pH meter must be calibrated using a standard solution. There are several kinds of standard solutions. For normal measurement, three standard solutions—with a pH of 4, 7, and 9—are sufficient to accurately calibrate the meter.

- pH 1.68 standard solution: Oxalate
0.05 mol/L tetra-potassium oxalate aqueous solution
- pH 4.00 standard solution: Phthalate
0.05 mol/L potassium hydrogen phthalate aqueous solution
- pH 6.86 standard solution: Neutral phosphate
0.025 mol/L potassium dihydrogen phosphate, 0.025 mol/L sodium dihydrogenphosphate aqueous solution
- pH 9.18 standard solution: Borate
0.01 mol/L tetra-sodium boric acid (boric sand) aqueous solution
- pH 12.45 standard solution: Saturated calcium hydroxide solution

**pH values of pH standard solutions at various temperatures
(NIST(former NBS) settings)**

Temp. (°C)	pH 1.68 standard solution Oxalate	pH 4.00 standard solution Phthalate	pH 6.86 standard solution Neutral phosphate	pH 9.18 standard solution Borate	pH 12.45 standard solution Saturated calcium hydroxide solution
0	1.666	4.003	6.984	9.464	13.423
5	1.668	3.999	6.951	9.395	13.207
10	1.670	3.998	6.923	9.332	13.003
15	1.672	3.999	6.900	9.276	12.810
20	1.675	4.002	6.881	9.225	12.627
25	1.679	4.008	6.865	9.180	12.454
30	1.683	4.015	6.853	9.139	12.289
35	1.688	4.024	6.844	9.102	12.133
38	1.691	4.030	6.840	9.081	12.043
40	1.694	4.035	6.838	9.068	11.984
45	1.700	4.047	6.834	9.038	11.841

Note

When the standard solutions use US settings, the pH 7 values shown in the table below are different and pH 9 becomes pH 10 (see next page).

pH values of pH 7 and pH 10 standard solutions at various temperatures (US-standard settings)

Temp. (°C)	pH 7 standard solution Neutral phosphate	pH 10 standard solution Carbonate
0	7.119	10.318
5	7.086	10.245
10	7.058	10.178
15	7.035	10.117
20	7.015	10.061
25	7.000	10.011
30	6.988	9.965
35	6.979	9.925
40	6.973	9.888
45	6.969	9.856

Note

Calibration is performed using Nernst's equation with the above values.

Using standard solutions

Standard solutions are used to calibrate the scale of the pH meter employed to measure the unknown pH of a solution. Standard solutions of pH 4, 7, and 9 are used in combination according to the particular conditions of the solution that is to be inspected.

When the approximate pH value is desired (1-point calibration)

Use the pH 7 standard solution or a standard solution that approximates the pH value of the solution that is to be inspected.

When it is known beforehand whether the test solution is acidic or alkaline (2-point calibration)

Acidic: Use the pH 4 and 7 standard solutions.

Alkaline: Use the pH 7 and 9 standard solutions.

When an unknown solution is to be inspected (3-point calibration)

Use the pH 4, 7, and 9 standard solutions.

Other

When finding the pH of other solutions, perform 2-point or 3-point calibration using pH 2, 4, 7, 9, or 12 standard solutions randomly, then measure the test solution.

7.2 mV (oxidation-reduction potential [ORP]) measurement

ORP principles

ORP is an abbreviation for oxidation-reduction potential. ORP is the energy level (potential) determined according to the state of equilibrium between the oxidants (M^{Z+}) and reductants ($M^{(Z-n)+}$) that coexist within a solution.

For one type of equilibrium in a solution:



If only $M^{(Z-n)+}$ exists within a solution, a metal electrode (platinum, gold, etc.) and a reference electrode are inserted into the solution, forming the ORP measuring system shown in Fig. 1. Measuring the potential (ORP) that exists between the two electrodes enables the potential to generally be expressed by the following equation.

$$E = E_0 - \frac{RT}{nF} \ln \frac{aM^{(Z-n)+}}{aM^{Z+}} \quad \dots\dots$$

E: Electric potential E_0 : Coefficient R: Gas coefficient
 T: Absolute temperature n: Electron count
 F: Faraday constant a: Activity

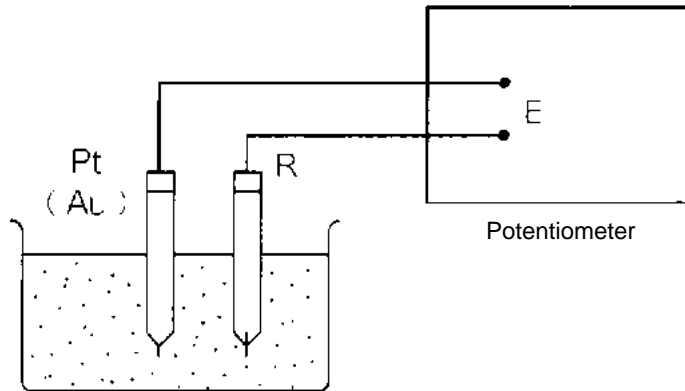

Fig. 1 ORP measuring system

For example, for a solution in which trivalent iron ions coexist with bivalent iron ions, equations and would be as follows.



$$E = E_0 - \frac{RT}{F} \ln \frac{aFe^{2+}}{aFe^{3+}} \quad \dots\dots$$

When only one type of equilibrium state exists in the solution, the ORP of the solution can only be determined by equation . What is important here is that ORP is determined by the ratio of activity between the oxidant (Fe^{3+}) and the reductant (Fe^{2+}) (using the equation aFe^{2+} / aFe^{3+}). In actuality, however, many kinds of states of equilibrium exist simultaneously between various kinds of ions, in most solutions. This means that under actual conditions, ORP cannot be expressed using

the simple equation shown above and that the physical and chemical significance with respect to the solution is not very clear.

In this respect, the value of ORP must be understood to be only one indicator of the property of a solution. The measurement of ORP is widely used, however, as an important index in the analysis of solutions (potentiometric titration) and in the disposal and treatment of solutions.

Recently, various claims have appeared regarding this matter. For example, that a high degree of ORP is effective in sterilization, or that drinking water that has a low ORP reduces the chance of illness by reacting with the activated oxygen in the cells of the body. ORP is used as an index for alkaline drinking water.

Standard electrode (reference electrode) types and ORP

The ORP of a solution that is obtained through measurement is a value that corresponds to the reference electrode employed. If different kinds of reference electrodes are used for measurement, the ORP value of the same solution may appear to be different.

HORIBA uses Ag/AgCl with 3.33 mol/L KCl as the reference solution for reference electrodes. According to general technical literature, standard hydrogen electrodes (N.H.E.) are often used as the standard electrode. The relationship between N.H.E. and the ORP that is measured using an Ag/AgCl with 3.33 mol/L KCl electrode is expressed by the following equation.

$$E_{\text{N.H.E.}} = E + 206 - 0.7(t - 25) \text{ mV} \quad t = 0 - 60^\circ\text{C}$$

$E_{\text{N.H.E.}}$: Measured ORP value using N.H.E. as the reference electrode

E : Measured ORP value using Ag/AgCl with 3.33 mol/L KCl as the reference electrode

Potential sign

Standard ORP is expressed in the following way, in literature related to electrochemistry and analytical chemistry.

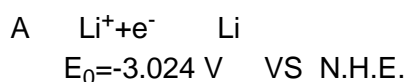

However, in some literature, the “+” and “-” signs are reversed.

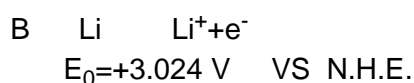

In expressions like B, above, the reaction is just reversed and there is no essential difference. But this kind of expression does invite confusion. The majority of the world is consistent in its use of the signs as they are used in A, above. For this reason, HORIBA also uses signs concerning ORP that are consistent with A.

ORP standard solution

There are two kinds of standards substances. Under normal circumstances, it is sufficient to use only that type of substance which is closest to the measured value.

Indicated value of ORP standard solution at various temperatures (mV)

temp. (°C)	160 - 22 Phthalic-acid chloride + quinhydrone	160 - 51 Neutral phosphate + quinhydrone
5	+274.2	+111.9
10	+270.9	+106.9
15	+266.8	+101.0
20	+262.5	+95.0
25	+257.6	+89.0
30	+253.5	+82.7
35	+248.6	+76.2
40	+243.6	+69.0

Operation check using standard solution

Note

Standard solution is not used only for the calibration of the meter, but to confirm whether or not the condition of electrodes is good.

1. Add 250 mL pure (de-ionized) water to one packet of any of the previously listed standard solutions and mix well. (When mixing, the excess quinhydrone [a black powder] will float to the surface of the solution.)
2. Immerse a washed and dried ORP electrode in the ORP standard solution and measure the mV value.
3. If the electrode and the meter itself are working correctly, numerical values within ± 15 mV of those listed in Table 1 should be obtained.
4. If measurements falling within 15 mV of the values listed above are not obtained using this method, measure the solution again after replacing the reference electrode internal solution and removing any dirt from the surface of the metal electrode by moistening a cotton swab with alcohol or a neutral cleaning agent and lightly rubbing the electrode or by soaking the electrode in diluted nitric acid (1:1 nitric acid).
5. If measurements within 15 mV of the values are still not obtained after re-measuring, the reference electrode or the meter may be faulty. Either replace the electrode or have the meter inspected.

Note

If the prepared ORP standard solution is allowed to stand in open air for one hour or more, it may undergo transformation. For this reason prepared ORP standard solution cannot be stored.

When measuring a solution that has low concentrations of oxidants and reductants after conducting an operational check using a standard substance, the measured values may not stabilize or the results of measurement might not be repeatable. If this is the case, use the meter after immersing the electrodes in the solution again and mixing it thoroughly.

Precautions when measuring actual samples

- Note that when measuring the ORP of a solution that has extremely low concentrations of oxidants and reductants (such as tap water, well water, or water treated with purifying equipment), there may be less responsiveness, repeatability, and stability, in general.
- When alkaline water is allowed to stand, its ORP undergoes considerable changes. Always measure alkaline ion water promptly.

7.3 Specifications

Measurement target

Target	Item	Description
pH	Measurement principle	Glass electrode
	Display range	pH -2.00 – 16.00
	Measurement range	pH 0.00 – 14.00
	Resolution	0.01 pH
	Repeatability	±0.01 pH ±1digit
Temp.	Measurement principle	Thermistor
	Measurement range	0.0 – 100.0 °C
	Resolution	0.1 °C
	Repeatability	±0.1 °C ±1digit
mV	Measurement range	±1999 mV
	Resolution	1 mV
	Repeatability	±1 mV ±1digit

Items in common among meter models

Data memory capacity	Max. 300 pieces of data
Power	Dry-cell batteries with automatic power-off function
Ambient temperature	0 – 45 °C
Dimensions	79(H) × 179(W) × 230(D) mm (not including stand)
Mass of main unit	Approx. 1 kg (including batteries)

7.4 Default settings

Category	Item	Default values
Common settings	Temperature compensation	Automatic temperature compensation
	Manual temperature compensation	25 °C
	Automatic power OFF	Approx. 30 min (ON)
	Sample ID	00000
	Calibration cycle	OFF
pH	Standard calibration solution	NIST
	Calibration setting	Asymmetric potential: 0mV Sensitivity: 100%

7.5 Operation flowcharts

The following flowcharts summarize meter operations.

F-51 operation flow

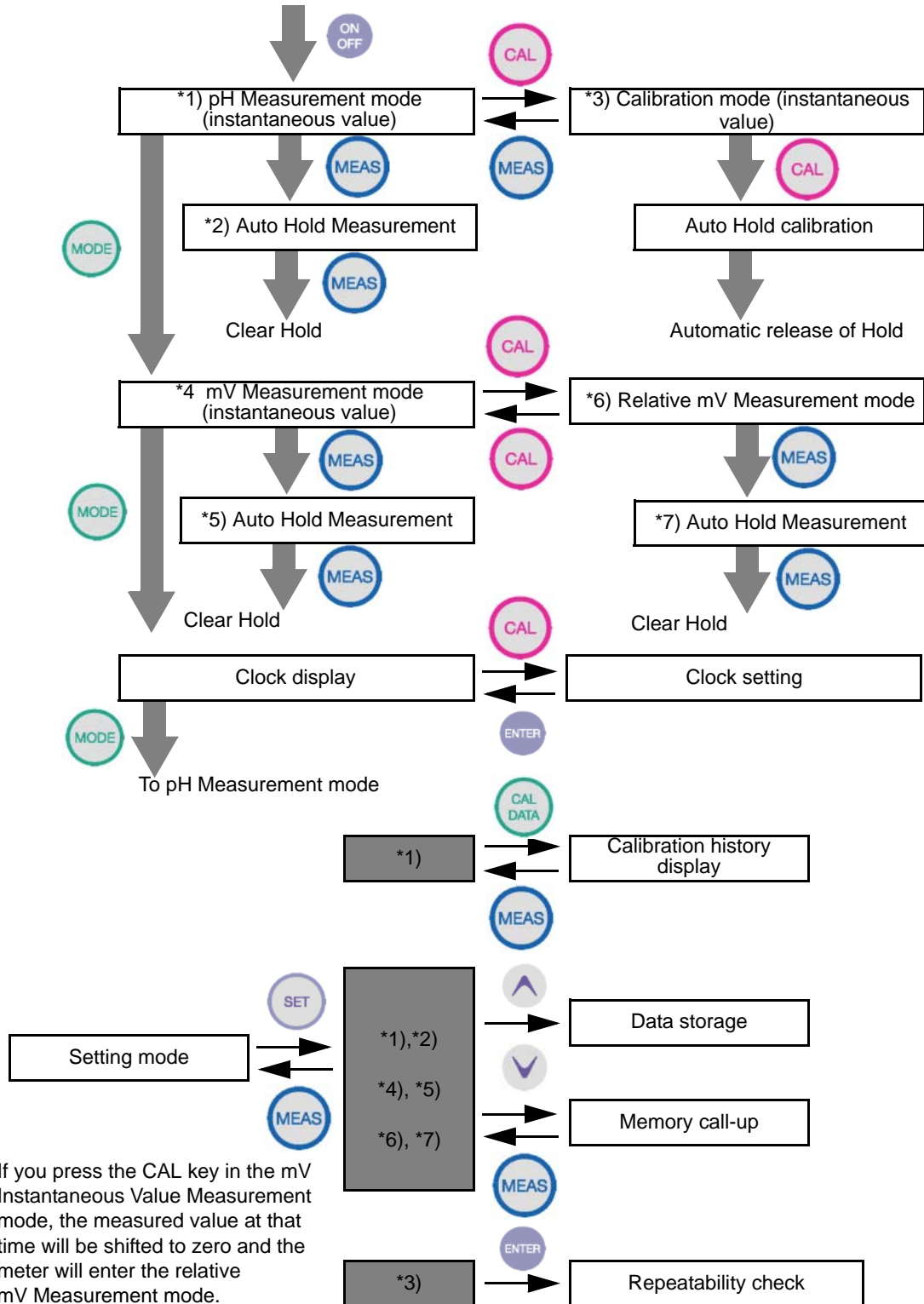

If you press the CAL key in the mV Instantaneous Value Measurement mode, the measured value at that time will be shifted to zero and the meter will enter the relative mV Measurement mode.

7.6 Pin layout of special cables

7.6.1 RS-232C communications cable

Meter main unit		Printer
MINI DIN8M		D-SUB 9-PIN
2;CTS	-	7;RTS
3;TXD	-	2;RXD
4;GND	-	5;GND
5;RXD	-	3;TXD

7.6.2 Cable for CITIZEN printer

CBM-910-24RJ100-A

Meter main unit		Printer
MINI DIN8M		D-SUB 25-PIN
2;CTS	-	20;BUSY
3;TXD	-	3;RXD
4;GND	-	7;GND
5;RXD	-	2;TXD

7.6.3 Cable for SEIKO printer

DPU-H245AS-A03A

Meter main unit		Printer
MINI DIN8M		D-SUB 25-PIN
2;CTS	-	8;BUSY
3;TXD	-	3;DATA
4;GND	-	5;GND
5;RXD	-	2;OPEN

7.7 Spare and optional parts

This section lists spare and optional parts for the pH meter.
These parts are available through HORIBA distributors. Place an order specifying their name, model, and part number.

7.7.1 Spare parts list

pH electrode (with built-in temperature sensor)

Part name	Model	Part number	Remarks
D-50 series standard electrode	9621-10D	9096001700	Plastic-body electrode (for immersion measurement)
F-50 series standard electrode	9611-10D	9096001800	Glass-body electrode (reinforced responsive glass)
Laboratory-use electrode for slurry samples	9677-10D	9096002000	Built-in washable reference electrode (reinforced responsive glass)
Laboratory-use electrode for micro samples	9669-10D	9096001900	Electrode incorporating temperature sensor compatible with micro sample measurement Tip: $\phi 3.55$ mm

pH electrode (without built-in temperature sensor)

Part name	Model	Part number	Remarks
Low-end electrode	6066-10C	9003013400	Glass-body electrode
Electrode for NMR tubes	6069-10C	9003013500	Tip: $\phi 3.180$ mm

ORP electrode (with built-in temperature sensor)

Part name	Model	Part number	Remarks
Standard ORP electrode	9300-10D	9096000400	Flat platinum type

ORP electrode (without built-in temperature sensor)

Part name	Model	Part number	Remarks
ORP electrode	6861-10C	9003013100	Bar-shaped platinum type

pH standard solution

Part name	Model	Part number	Remarks
pH2 standard solution	100-2	9003001500	500 mL Accuracy: ± 0.02 pH
pH4 standard solution	100-4	9003001600	
pH7 standard solution	100-7	9003001700	
pH9 standard solution	100-9	9003001800	

Part name	Model	Part number	Remarks
pH2 standard solution powder	150-2	9003002600	Makes 500 mL (10 packets) Accuracy: ± 0.05 pH
pH4 standard solution powder	150-4	9003002700	
pH7 standard solution powder	150-7	9003002800	
pH9 standard solution powder	150-9	9003002900	

Standard solution for ORP check

Part name	Model	Part number	Remarks
Standard solution for ORP check	160-51	9003003100	ORP 95 mV For Ag/AgCl electrode at 20°C
	160-22	9003003000	ORP 262 mV For Ag/AgCl electrode at 20°C

Internal reference solution

Part name	Model	Part number	Remarks
Internal reference solution	#300	9003003200	250 mL

Cleaning liquid

Part name	Model	Part number	Remarks
Cleaning liquid for electrodes	#220	9096002500	For pH, ORP, and ion electrodes

7.7.2 Optional parts

Part name		Part number	Remarks	
AC adapter for the pH meter	AC adapter	9096003100	Be sure to purchase the cable when purchasing the AC adapter.	
	Cable	For Japan		9096003200
		For US		9096003300
		For Europe		9096003400
Plain paper printer	Printer	For Japan	9096003500	
		For US	9096003600	
		For Europe	9096003700	
	Printer cable	9096003800		
	Roll paper	9096003900		
	Ink ribbon	9096004000		
Serial cable		9096004800		
Data collection software		9096005000		
Electrode stand		9096002700		
Stand arm		9096002800		

For any question regarding this product,
please contact your local agency, or
inquire from the Customer Registration
website (www.horiba.co.jp/register)

HORIBA,Ltd.

First edition:August 2003
CODE : I1001385000