



MONITORING PARTICLE SIZE REDUCTION OF PHARMACEUTICAL PRODUCTS BY MICROFLUIDIZERS USING LASER DIFFRACTION

Many particle size measurements are made to track size reduction operations such as milling, mixing, homogenizing, microfluidizing, etc. The size reduction unit operation is performed under set conditions or for a required time frame until a specified size is achieved, as determined by the measurement. The choice of particle size analysis technique can be based on the size distribution of the input, output, or both. The HORIBA laser diffraction analyzers are uniquely capable of measuring from several millimeters down to the nanometer scale, making it the instrument of choice for many size reduction operations. Since microfluidizers are capable of reducing particle size down to the nanoparticle scales (<100nm), HORIBA laser diffraction analyzers have long been the system of choice for monitoring their performance.

Introduction

One method for particle size reduction is the use of microfluidizers which expose the material to consistent shear levels using a unique fixed-geometry interaction chamber. Figure 1 shows a picture and basic schematic of a microfluidizer being used to reduce particles from 500 μm to 0.74 μm .

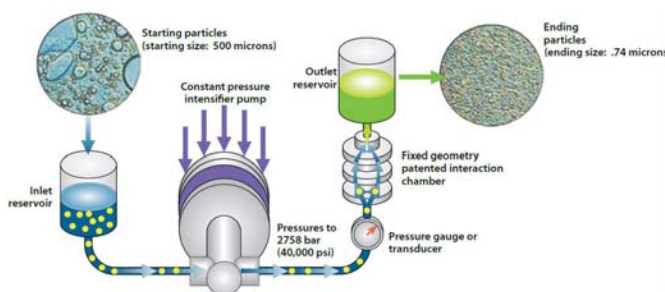

Figure 1: A microfluidizer

As depicted above, product is input into a reservoir which supports high solid content. A high pressure pump generates forces up to 40,000 psi (2578 bar) in order to force the product stream into precisely engineered

microchannels within the unique interaction chamber. Because of the ability to control shear rates, the smallest pressure required is typically used. Once inside the chamber, product is exposed to consistent and intense impact and shear forces and then is immediately cooled. This repeatable process results in tiny particles with a uniform distribution.

The key component of a microfluidizer is the fixed geometry interaction chamber (Figures 2 and 3) where the size reduction operation takes place. The fluid channels have typical dimensions in the range of 50 – 300 μm where sample velocities reach over 400 m/s. Shear rates inside the chamber can be as high as 10^7 s^{-1} . The size reduction operation is scalable from a few mL to tens of liters/minute.

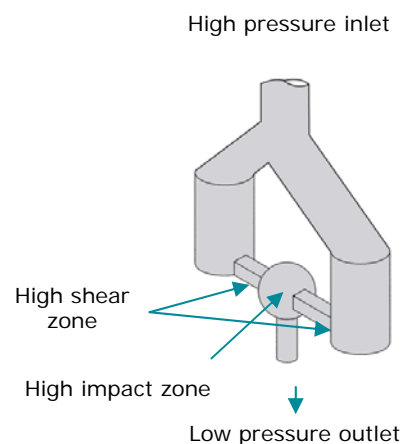

Figure 2: Single-slotted "Y"

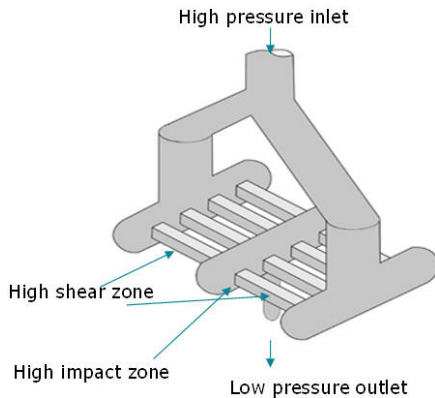

Figure 3: Multi-slotted "Y"

Applications

Active Pharmaceutical Ingredient (API)

One common use of a microfluidizer is particle size reduction of an active pharmaceutical ingredient (API). The images below show the particle size of the API before and after processing in the microfluidizer. The particle size analysis was performed using a HORIBA LA-910 laser diffraction analyzer.

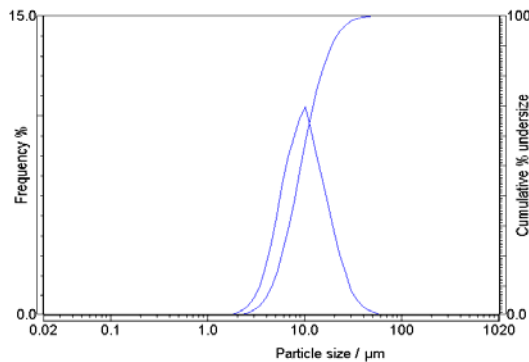
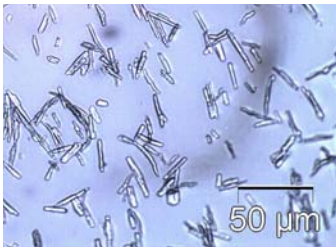

Figure 4: API before processing

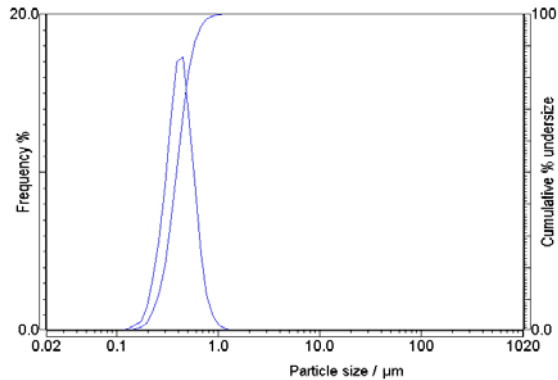
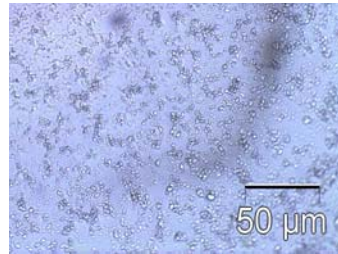

Figure 5: API after processing

Emulsion

This technology is also commonly used to reduce the droplet size distribution of emulsions. The images below show the particle size of an emulsion used as an ophthalmic solution before and after processing. The particle size analysis was performed using a HORIBA LA-910 laser diffraction analyzer.

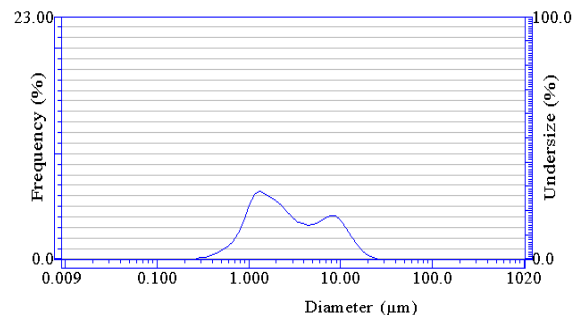

Figure 6: Emulsion before processing

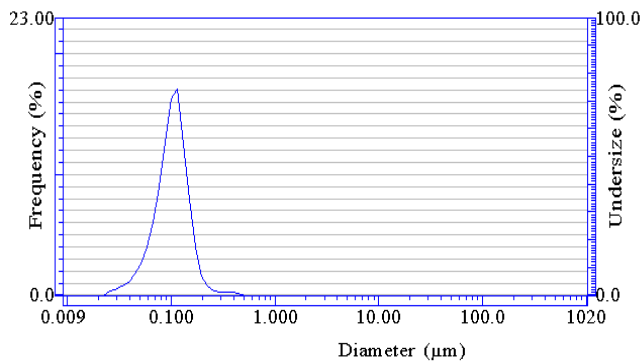
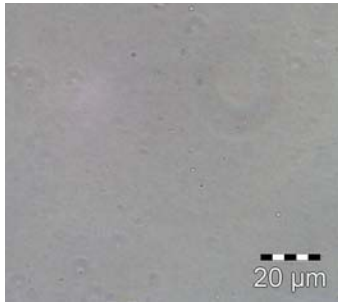

Figure 7: Emulsion after processing

Cell Disruption

Microfluidizer processors are tough on cells and gentle on proteins. Because *E. coli*, yeast, mammalian, plant, insect, fungi and algae cells all have specific shear requirements, Microfluidizer processors are ideally suited to rupture cells with high protein recovery. The images below show the particle size of the *E. coli* cells before and after processing in the microfluidizer. The particle size analysis was performed using a HORIBA LA-910 laser diffraction analyzer.

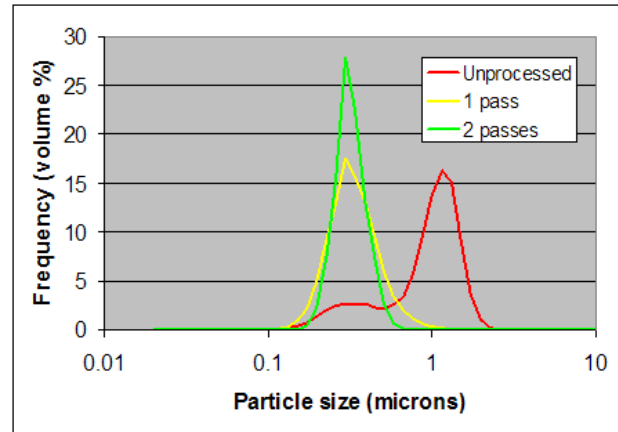
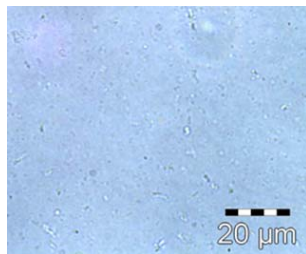
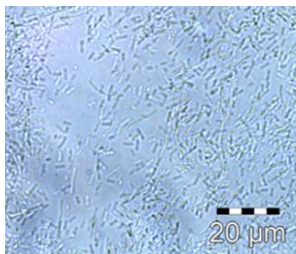

Figure 8: *E. coli* before and after processing

Conclusions

The HORIBA LA-910 proved capable of monitoring the particle size reduction of various samples processed by a microfluidizer. HORIBA laser diffraction analyzers have the highest sensitivity of any analyzer available, making them uniquely well-suited to applications where the median size will fall below 100 nm and/or when a small population of outlier particles must be detected. The Microfluidics applications lab in Newton, MA has successfully used their LA-910 to quantify particle size reduction on hundreds of samples across hundreds of applications.

For more information on microfluidizers please visit the Microfluidics website at:

www.mfics.com

Copyright 2010, HORIBA Instruments, Inc.
For further information on this document or our products, please contact:
HORIBA Instruments, Inc.
17671 Armstrong Ave.
Irvine, CA 92614 USA
1-800-4-HORIBA
www.horiba.com/us/particle
labinfo@horiba.com